

Parts Manual

NX340

Snow Blower



Revised 08/22/23
09.20068 Rev. 02



500 Venture Drive
Orrville Oh 44667
www.ventrac.com

[View all manuals](#)



Visit ventrac.com/manuals for the latest version of this parts manual. A downloadable operator's manual is also available.

Serial Number Description

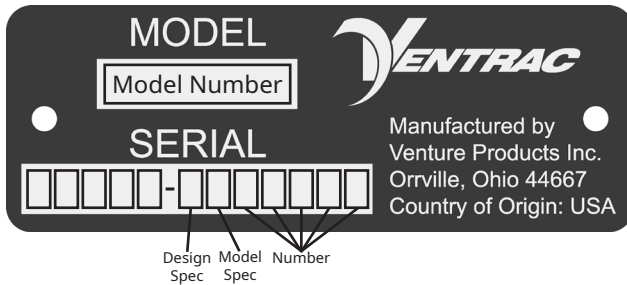

Notes

- If any component requires replacement, use only original Ventrac replacement parts.
- When ordering new components, be sure to order all required safety decals. All current safety decals must be affixed to the replacement components prior to installation of the component.

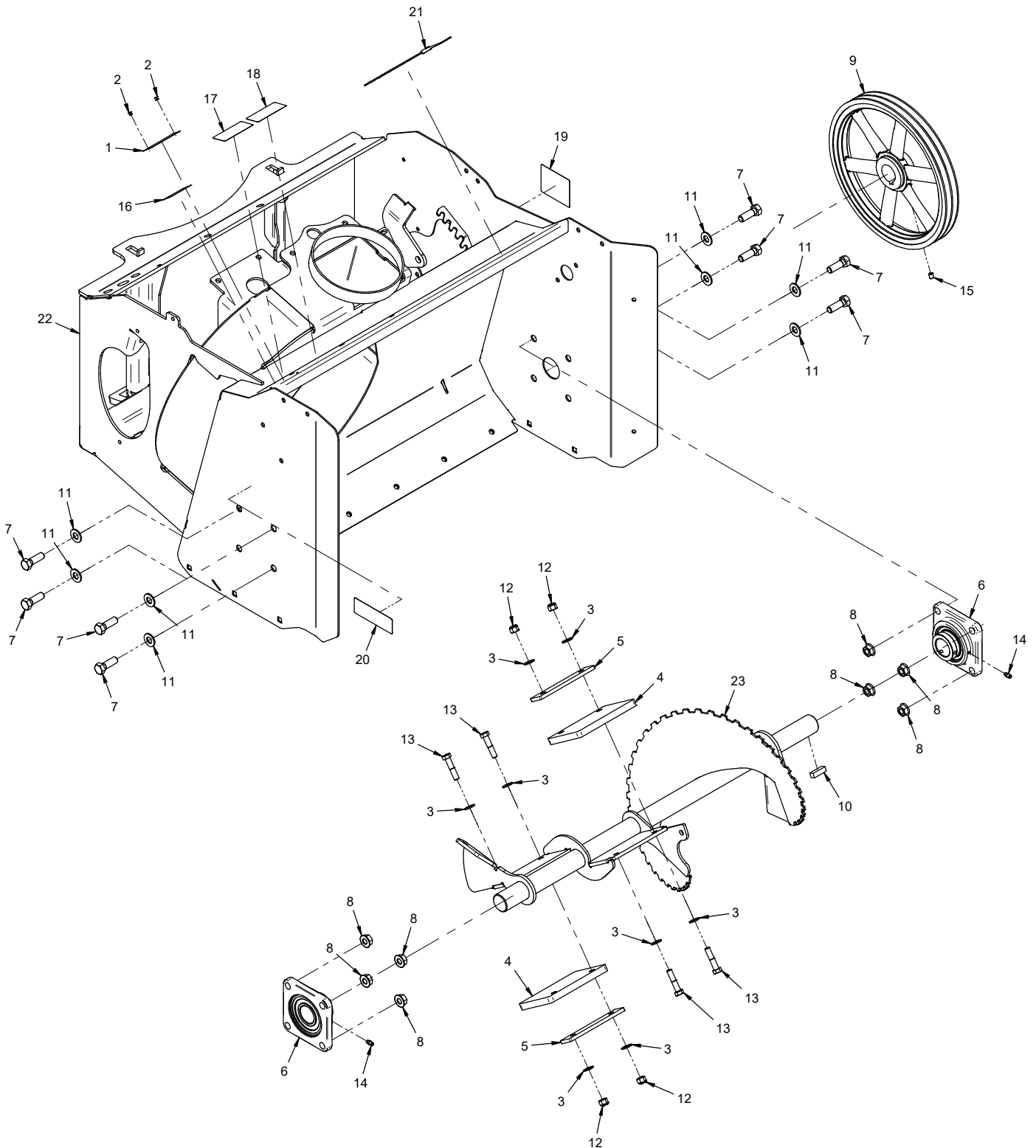

TABLE OF CONTENTS

PARTS	PAGE 4
Main Frame & Auger	4
Cutting Edge, Skid Shoes, & Auger Housing Crossbar.....	6
Snow Discharge Guide	8
Fan & Fan Bearing Mount.....	10
Discharge Chute & Post.....	12
Discharge Chute Extensions.....	14
Discharge Chute Rotation Drive.....	16
Gearbox, Input Drive, Output to Jack Shaft	18
Auger Drive & Cover	20
Fan Drive.....	22
Fan Drive Covers & Adjustment Cover Belting	24
Discharge Chute Guard & Cleaning Tool	26
70.8192 12 Volt Actuator Kit.....	28
70.8188 Deep Snow Kit	30

PARTS

ILLUSTRATED DRAWING Main Frame & Auger



PARTS

Main Frame & Auger

REF.	PART NO.	DESCRIPTION	QTY.
1	N/A	.Plate, Ventrac Serial Number	1
2	04.0007	.Rivet, Pop 1/8 X 1/8 S.S.	2
3	95.06-3	.Washer, Flat 3/8 SAE SS	8
4	NX-1154	.Paddle, Rubber	2
5	NX-1127	.Plate, Paddle Retainer	2
6	55.FB22023	.Bearing, Flange Block 1-7/16"	2
7	90.0812	.Bolt, 1/2-13 USS x 1-1/2	8
8	99.SF08	.Nut, SRF 1/2-13 USS	8
9	83.2AK12423	.Pulley, 2AK 12.4" 1-7/16" Bore	1
10	85.K0610	.Key, 3/8 X 1-1/4	1
11	95.08	.Washer, Flat 1/2 SAE	8
12	99.A06N-3	.Locknut, Nylon 3/8-16 SS	4
13	90.0614-3	.Bolt, 3/8-16 USS x 1-3/4 SS	4
14	29.GF0001	.Grease Ftg, 1/4 SAE ST	2
15	85.SS09	.Set Screw, 5/16-18 x 3/8"	1
16	00.0100	.Decal, Made In USA	1
17	00.0217	.Decal, Warning Read Owners Man (Serial # 01001-02510)	1
17	00.0619	.Decal, Read Operator's Manual (Serial # 02511-)	1
18	00.0220	.Decal, General Safety (Serial # 01001-02510)	1
18	00.0632	.Decal, Moving Parts Hazard (Serial # 02511-)	1
19	00.0492	.Decal, Shield Missing (Serial # 01001-02510)	2
19	00.0625	.Decal, Shield Missing (Serial # 02511-)	2
20	00.0208	.Decal, Danger Auger Hazard (Serial # 01001-02510)	1
20	00.0630	.Decal, Entanglement Hazard Auger (Serial # 02511-)	1
21	00.0383	.Decal, Ventrac	1
22	NX-6100	.Frame, Main Snowblower	1
23	NX-6103	.Auger, Snowblower	1

PARTS

ILLUSTRATED DRAWING Cutting Edge, Skid Shoes, & Auger Housing Crossbar

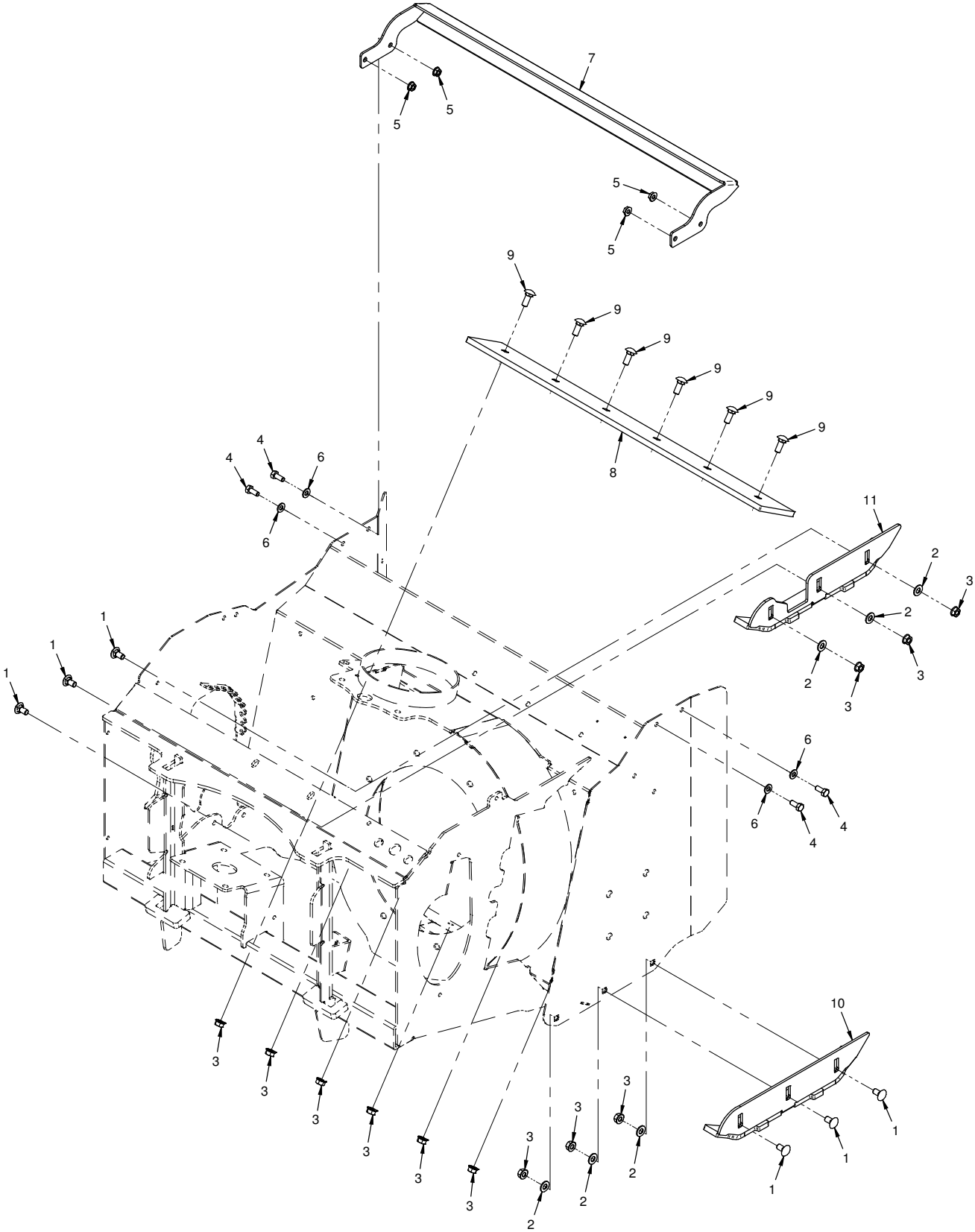

PARTS

Cutting Edge, Skid Shoes, & Auger Housing Crossbar

REF.	PART NO.	DESCRIPTION	QTY.
1	97.0606	.Bolt, Carriage 3/8-16 x 3/4	6
2	95.06	.Washer, Flat 3/8 SAE	6
3	99.SF06	.Nut, SRF 3/8-16 USS	12
4	90.0506-3	.Bolt, 5/16-18 USS x 3/4 SS	4
5	99.SF05-3	.Nut, SRF 5/16-18 USS Stainless	4
6	95.05-3	.Washer, Flat 5/16 SAE SS	4
7	NX-1149	.Crossbar, Auger Housing	1
8	NX-1151	.Cutting Edge, Snowblower NX	1
9	97.0608	.Bolt, Carriage 3/8-16 x 1	6
10	NX-6106	.Shoe, Skid Right	1
11	NX-6107	.Shoe, Skid Left	1

PARTS

ILLUSTRATED DRAWING Snow Discharge Guide

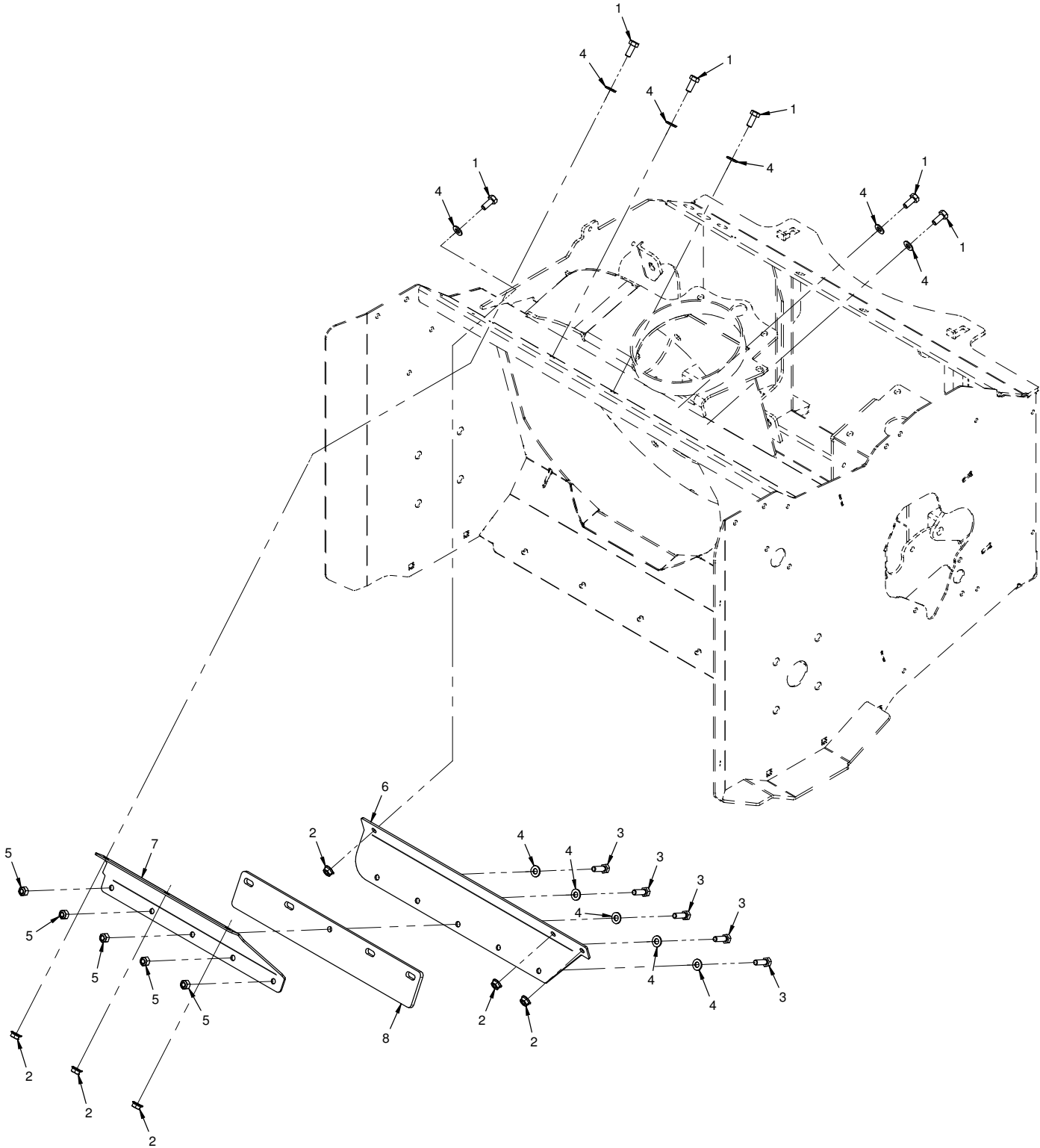

PARTS

Snow Discharge Guide

REF.	PART NO.	DESCRIPTION	QTY.
1	90.0506-3	.Bolt, 5/16-18 USS x 3/4 SS	6
2	99.SF05-3	.Nut, SRF 5/16-18 USS Stainless	6
3	90.0508-3	.Bolt, 5/16-18 USS x 1 SS	5
4	95.05-3	.Washer, Flat 5/16 SAE SS	11
5	99.A05N-3	.Locknut, Nylon 5/16-18 SS	5
6	NX-1136	.Guide, Snow Discharge	1
7	NX-1137	.Retainer, Snow Guide	1
8	NX-1155	.Belting, NX Rubber Curtain	1

PARTS

ILLUSTRATED DRAWING Fan & Fan Bearing Mount

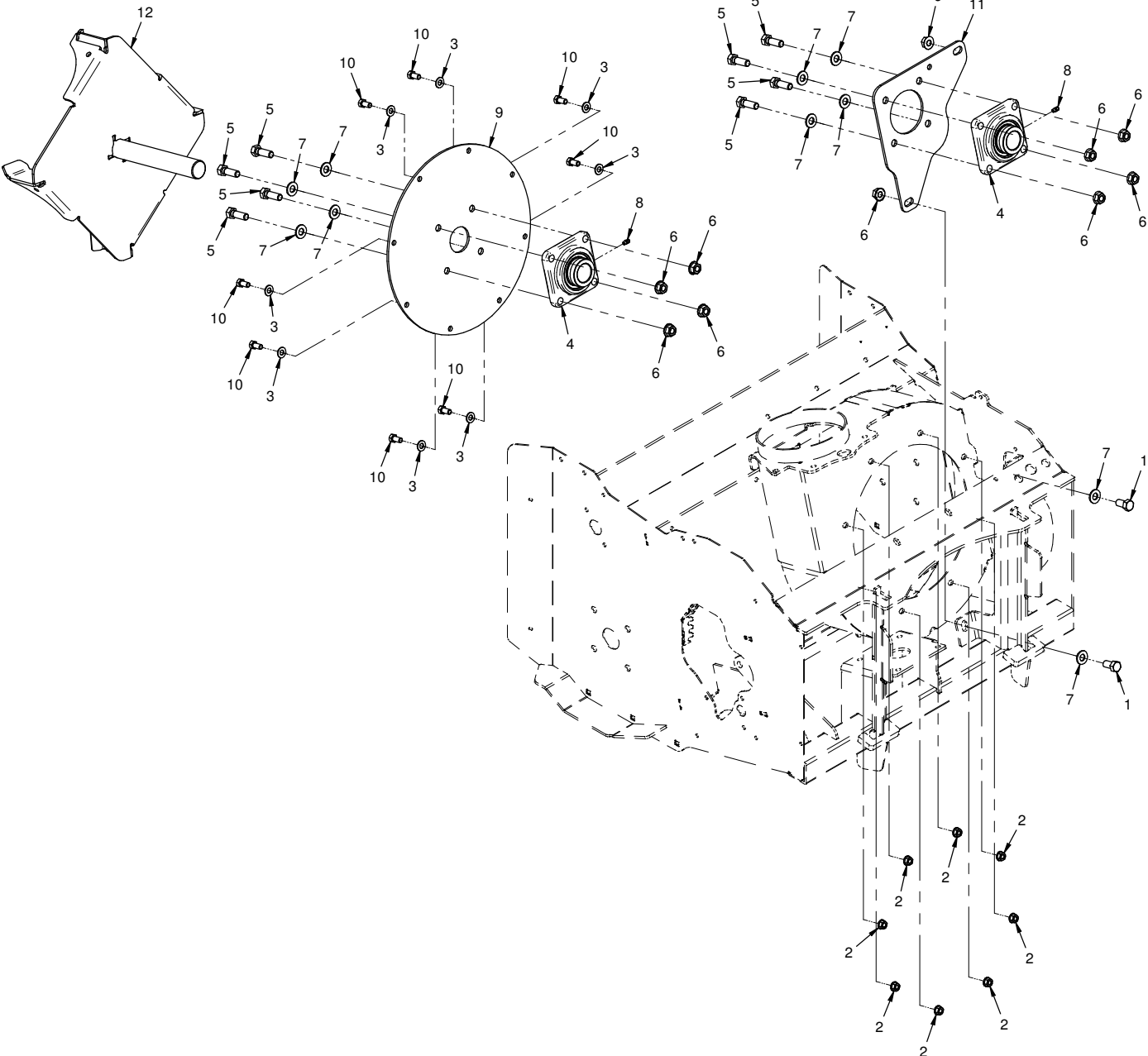
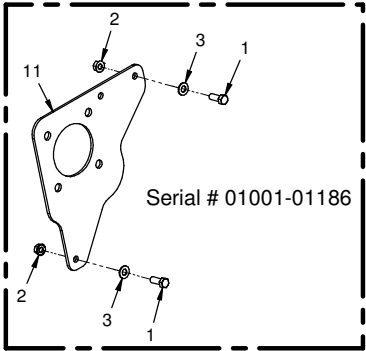

PARTS

Fan & Fan Bearing Mount

REF.	PART NO.	DESCRIPTION	QTY.
1	90.0608-3	.Bolt, 3/8-16 USS x 1 SS (Serial # 01001-01186)	2
1	90.0808	.Bolt, 1/2-13 USS x 1 (Serial # 01187-)	2
2	99.SF06-3	.Nut, SRF 3/8-16 USS Stainless	8
3	95.06-3	.Washer, Flat 3/8 SAE SS	8
4	55.FB22023	.Bearing, Flange Block 1-7/16"	2
5	90.0812	.Bolt, 1/2-13 USS x 1-1/2	8
6	99.SF08	.Nut, SRF 1/2-13 USS	10
7	95.08	.Washer, Flat 1/2 SAE	10
8	29.GF0001	.Grease Ftg, 1/4 SAE ST	2
9	NX-1106	.Housing Disk, Fan Bearing Mount	1
10	90.0606-3	.Bolt, 3/8-16 USS x 3/4SS	8
11	NX-1107	.Plate, Fan Bearing Mount (Serial # 01001-01186)	1
11	NX-1180	.Plate, Fan Bearing Mount w/Slots (Serial # 01187-)	1
12	NX-6102	.Fan, Blower	1

PARTS

ILLUSTRATED DRAWING Discharge Chute & Post

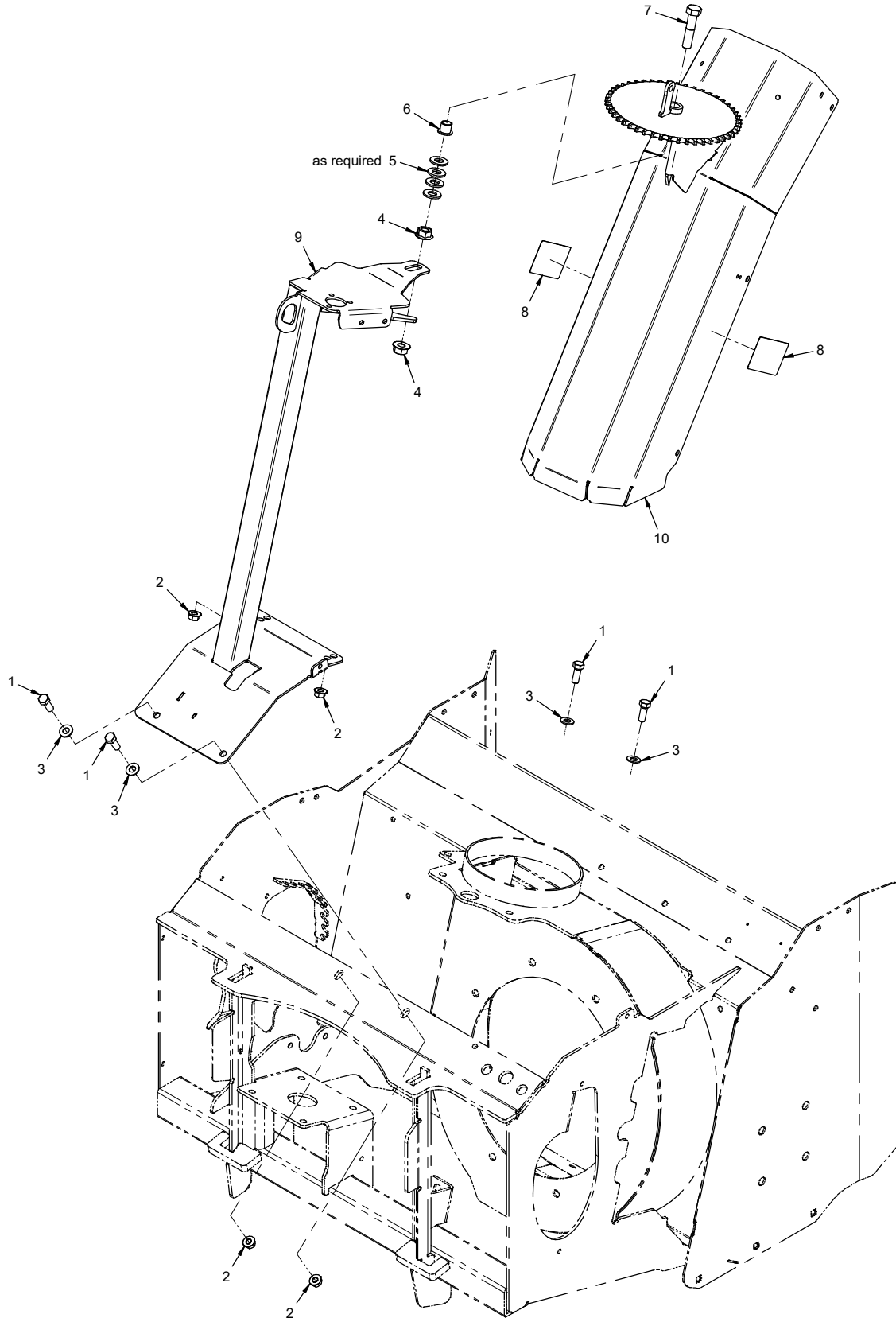

PARTS

Discharge Chute & Post

REF.	PART NO.	DESCRIPTION	QTY.
1	90.0608-3	.Bolt, 3/8-16 USS x 1 SS	4
2	99.SF06-3	.Nut, SRF 3/8-16 USS Stainless	4
3	95.06-3	.Washer, Flat 3/8 SAE SS	4
4	99.SF08	.Nut, SRF 1/2-13 USS	2
5	95.08	.Washer, Flat 1/2 SAE	as required
6	85.B0027	.Bushing, 1/2 ID X 5/8 OD X 5/8	1
7	90.0818	.Bolt, 1/2-13 USS x 2-1/4	1
8	00.0409	.Decal, Discharge Chute Safety (Serial # 01001-02510)	2
8	00.0640	.Decal, Discharge Chute Safety (Serial # 02511-)	2
9	NX-6101	.Post, Chute Mount	1
10	62.0990	.Chute, Main Blower Discharge	1

PARTS

ILLUSTRATED DRAWING Discharge Chute Extensions

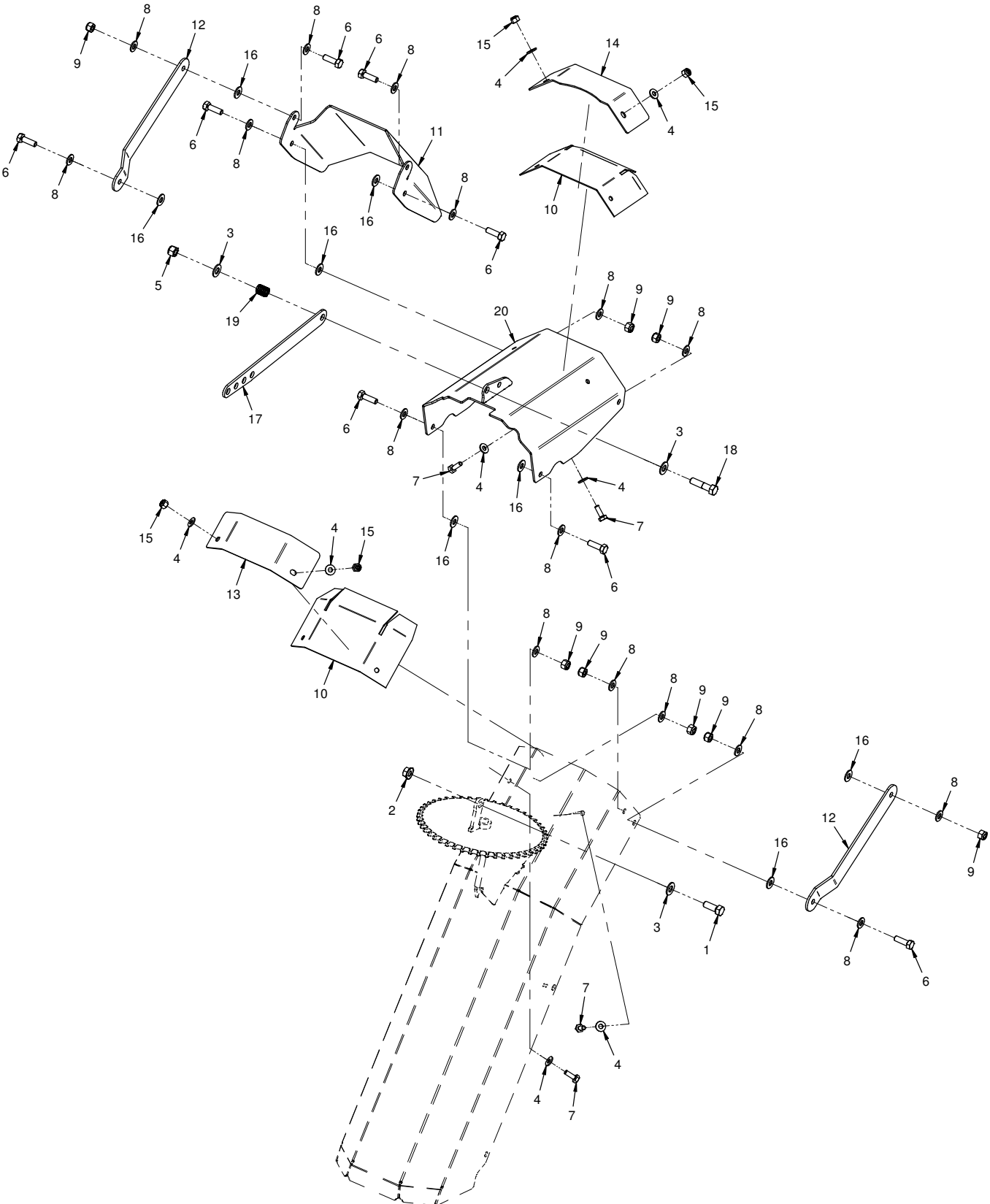

PARTS

Discharge Chute Extensions

REF.	PART NO.	DESCRIPTION	QTY.
1	90.0608-3	.Bolt, 3/8-16 USS x 1 SS	1
2	99.SF06-3	.Nut, SRF 3/8-16 USS Stainless	1
3	95.06-3	.Washer, Flat 3/8 SAE SS	3
4	95.04-3	.Washer, Flat 1/4 SAE SS	8
5	99.A06N-3	.Locknut, Nylon 3/8-16 SS	1
6	90.0508-3	.Bolt, 5/16-18 USS x 1 SS	8
7	90.0406-3	.Bolt, 1/4-20 USS x 3/4 SS	4
8	95.05-3	.Washer, Flat 5/16 SAE SS	16
9	99.A05N-3	.Locknut, Nylon 5/16-18 SS	8
10	44.0272	.Plastic, Chute Liner	2
11	62.0992	.Chute, Final Extension	1
12	42.0461	.Link, Chute Deflector Control	2
13	64.1484	.Clamp, Chute Liner Main	1
14	64.1485	.Clamp, Chute Liner Upper	1
15	99.A04N-3	.Locknut, Nylon 1/4-20 USS SS	4
16	05.0055	.Washer, Nylon .34 x .74 x .062	8
17	NX-1175	.Link, Chute Deflector Adjust NX340	1
18	90.0612-3	.Bolt, 3/8-16 USS x 1-1/2 SS	1
19	41.0039	.Spring, Comp. 9/16 OD X 5/8	1
20	NX-6108	.Chute, Mid Discharge Section	1

PARTS

ILLUSTRATED DRAWING Discharge Chute Rotation Drive

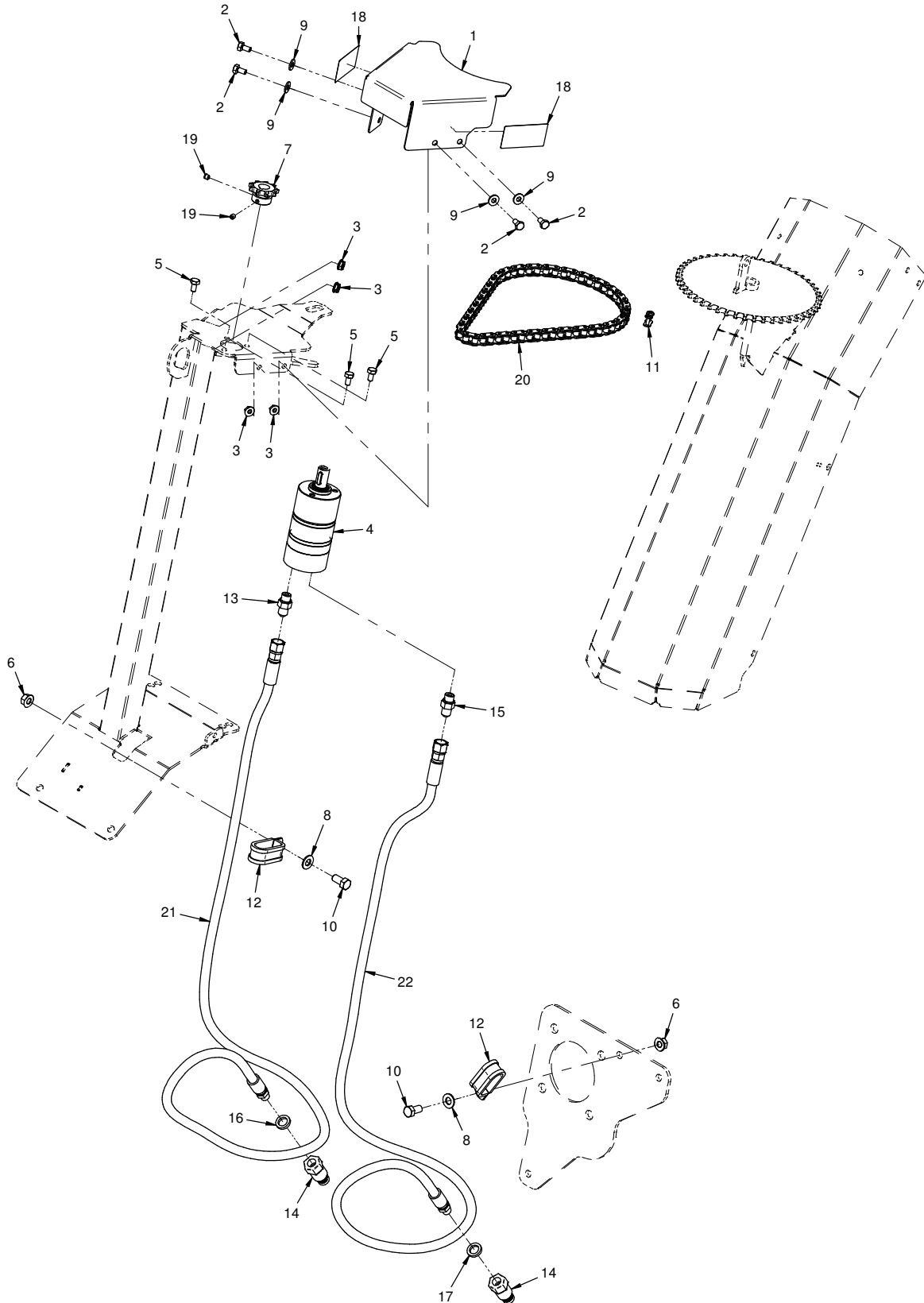

PARTS

Discharge Chute Rotation Drive

REF.	PART NO.	DESCRIPTION	QTY.
1	NX-1103	.Shield, Chute Rotation Chain	1
2	90.0404-3	.Bolt, 1/4-20 USS x 1/2 SS	4
3	99.SF04-3	.Nut, SRF 1/4-20 USS Stainless	4
4	21.0113	.Motor, HYD 1.93 CU.IN	1
5	91.0404	.Bolt, 1/4-28 SAE x 1/2"	3
6	99.SF06-3	.Nut, SRF 3/8-16 USS Stainless	2
7	83.H409	.Sprocket, #40 9-T HRD 5/8 Bore	1
8	95.06-3	.Washer, Flat 3/8 SAE SS	2
9	95.04-3	.Washer, Flat 1/4 SAE SS	4
10	90.0606-3	.Bolt, 3/8-16 USS x 3/4SS	2
11	81.0056-1	.Link, Conn. #40 SS	1
12	11.0071	.Clamp, Cushioned 3/4" 2-Tube	2
13	24.0019	.Fitting, Orifice 6400-06-06 Drilled .025"	1
14	23.0176	.Coupler, Male Flat Face Quick 1/4	2
15	25.6400-06-06-CP	.Fitting, M Conn 3/8 X 3/8	1
16	05.0117	.Washer, .544 ID x .817 x .14 Yel	1
17	05.0116	.Washer, .544 ID x .817 x .14 Red	1
18	00.0216	.Decal, Warning Moving Parts (Serial # 01001-02510)	2
18	00.0631	.Decal, Finger/Hand Entanglement (Serial # 02511-)	2
19	85.SS19	.Set Screw, 1/4-20 x 1/4"	2
20	81.0147	.Chain, Roller #40SS-1 x 30-1/2" SS	1
21	20.0363	.Hose, 1/4x56.00 SAE 100R17AR	1
22	20.0363	.Hose, 1/4x56.00 SAE 100R17AR	1

PARTS

ILLUSTRATED DRAWING Gearbox, Input Drive, Output to Jack Shaft

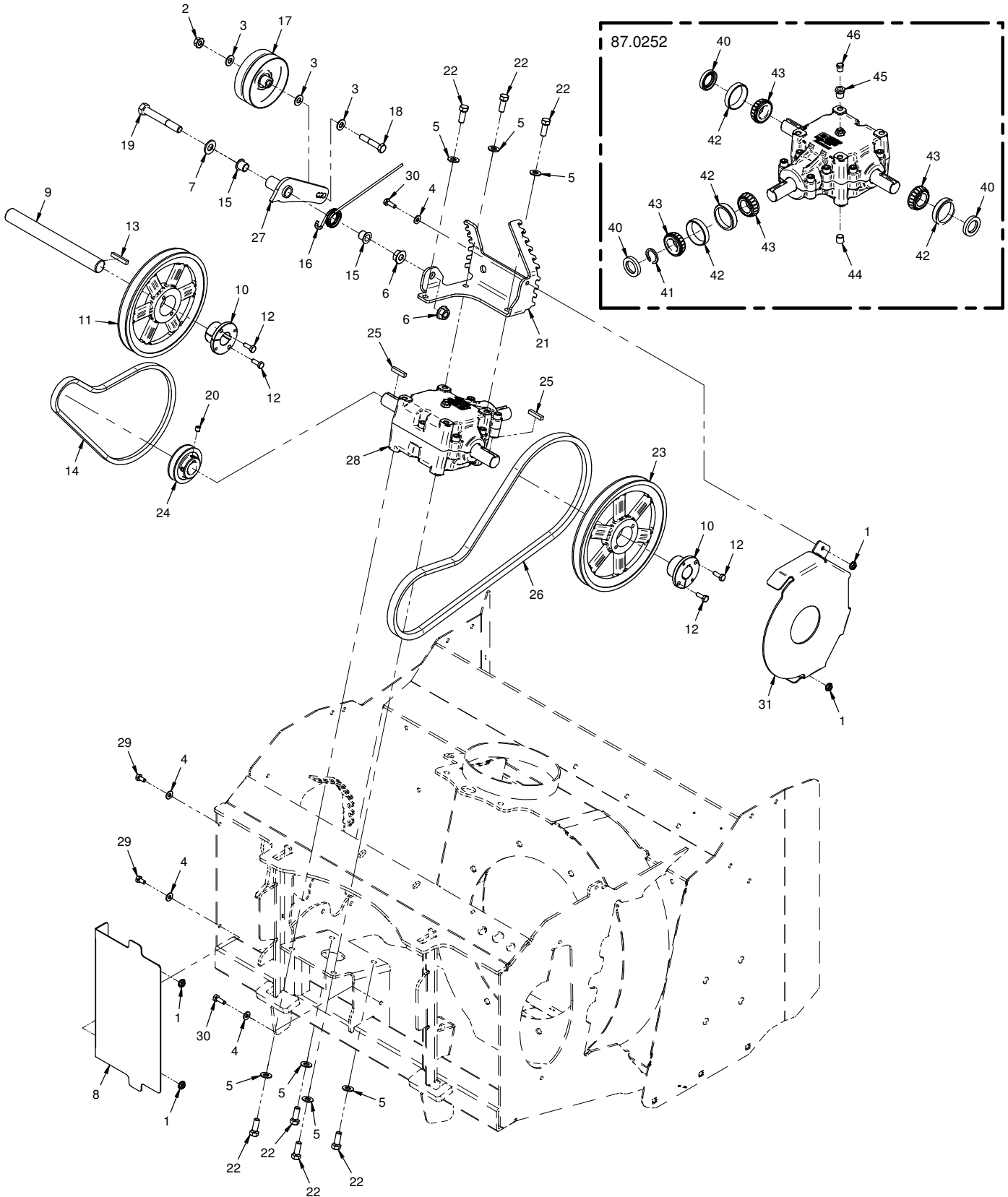

PARTS

Gearbox, Input Drive, Output to Jack Shaft

REF.	PART NO.	DESCRIPTION	QTY.
1	99.SF04-3	Nut, SRF 1/4-20 USS Stainless	4
2	99.SF06-3	Nut, SRF 3/8-16 USS Stainless	1
3	95.06-3	Washer, Flat 3/8 SAE SS	3
4	95.04-3	Washer, Flat 1/4 SAE SS	4
5	95.06	Washer, Flat 3/8 SAE	7
6	99.SF08	Nut, SRF 1/2-13 USS	2
7	95.08	Washer, Flat 1/2 SAE	1
8	NX-1102	Shield, Jack Shaft Drive	1
9	NX-1165	Shaft, Jack NX Snowblower	1
10	83.H16S	Bushing, 1" Split 1/4" Key	2
11	83.BK85H	Pulley, 8.5" H-Bush	1
12	90.0406	Bolt, 1/4-20 USS x 3/4"	4
13	85.K0412	Key, 1/4 X 1-1/2	1
14	81.A033	Belt, A33	1
15	85.B0027	Bushing, 1/2 ID X 5/8 OD X 5/8	2
16	41.0066	Spring, Single Torsion LH	1
17	83.0042	Pulley, Dbl Idler Flat 4 X 3/8	1
18	90.0616-3	Bolt, 3/8-16 USS x 2 SS	1
19	90.0828	Bolt, 1/2-13 USS x 3-1/2	1
20	85.SS15	Set Screw, 5/16-18 x 5/16	1
21	NX-1124	Bracket, Belt Tensioner	1
22	90.0608	Bolt, 3/8-16 USS x 1	7
23	83.BK90H	Pulley, 9" H-Bush	1
24	83.AK2816	Pulley, AK 2.8" 1" Bore	1
25	85.K0410	Key, 1/4 X 1-1/4	2
26	81.B048	Belt, B48	1
27	NX-6105	Arm, Belt Tension Idler	1
28	87.0252	Gearbox, 1" Shaft 1:1 CW/CW/CCW	1
29	90.0404-3	Bolt, 1/4-20 USS x 1/2 SS	2
30	90.0406-3	Bolt, 1/4-20 USS x 1/2 SS (Serial # 01107-)	2
31	NX-1176	Bracket, Belt Retainer (Serial # 01107-)	1
40	89.0075	Seal, Oil	3
41	04.0026	Retaining Ring, Ext 1.000 Shft	1
42	55.0076	Bearing, Cup 1.980	4
43	55.0075	Bearing, Cone 1.000	4
44	29.P04-1	Pipe, Plug 1/4 Hex Socket ZP	1
45	29.B0204G	Pipe, Bushing 1/8 x 1/4 Galv	1
46	29.0090	Pipe, Breather Plug 1/8	1

PARTS

ILLUSTRATED DRAWING Auger Drive & Cover

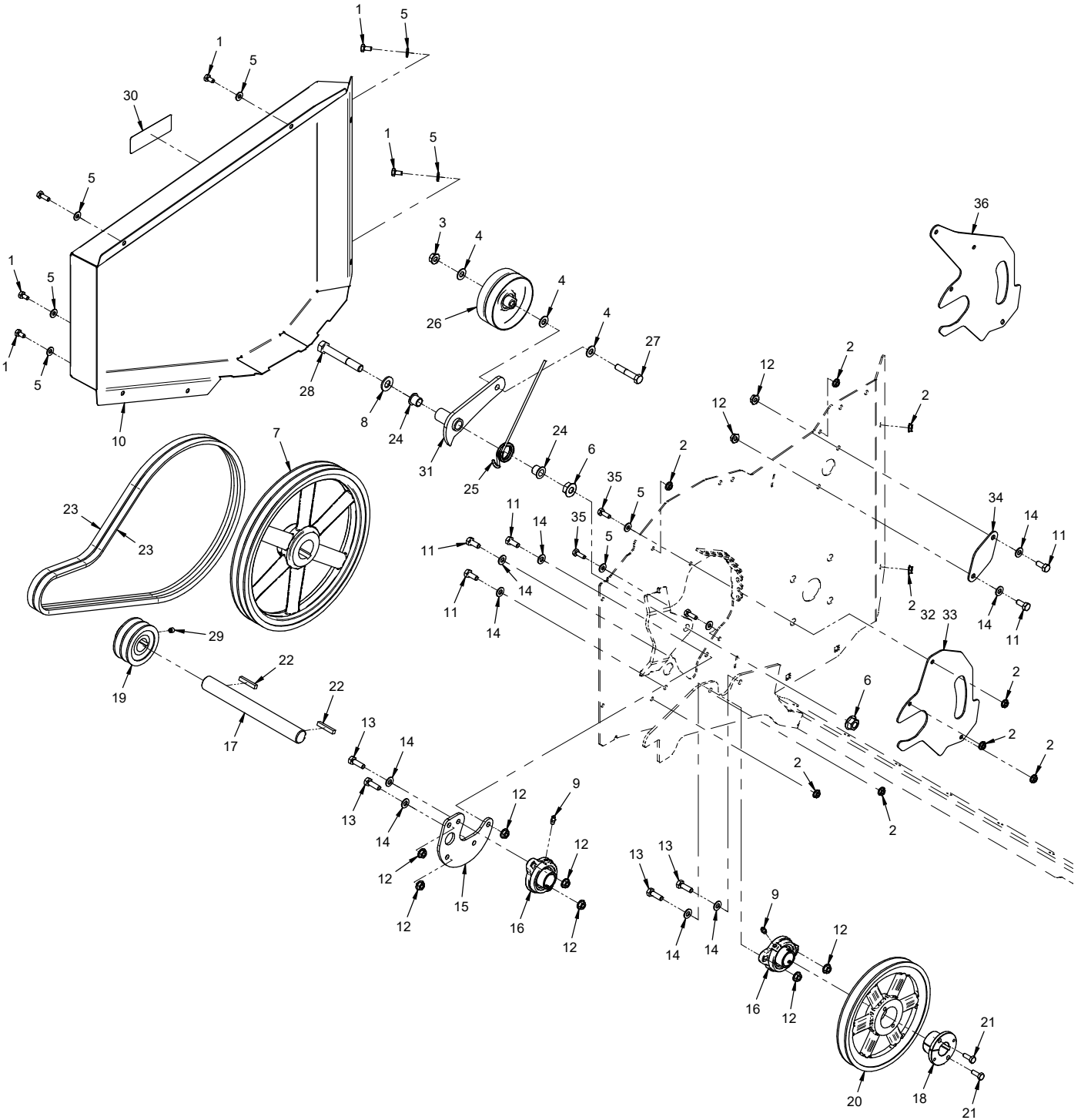

PARTS

Auger Drive & Cover

REF.	PART NO.	DESCRIPTION	QTY.
1	90.0404-3	.Bolt, 1/4-20 USS x 1/2 SS	5
2	99.SF04-3	.Nut, SRF 1/4-20 USS Stainless	9
3	99.SF06-3	.Nut, SRF 3/8-16 USS Stainless	1
4	95.06-3	.Washer, Flat 3/8 SAE SS	3
5	95.04-3	.Washer, Flat 1/4 SAE SS	9
6	99.SF08	.Nut, SRF 1/2-13 USS	2
7	83.2AK12423	.Pulley, 2AK 12.4" 1-7/16" Bore	1
8	95.08	.Washer, Flat 1/2 SAE	1
9	29.GF0001	.Grease Ftg, 1/4 SAE ST	2
10	NX-1100	.Shield, Auger Drive Belt Cover	1
11	90.0506-3	.Bolt, 5/16-18 USS x 3/4 SS	5
12	99.SF05-3	.Nut, SRF 5/16-18 USS Stainless	9
13	90.0508-3	.Bolt, 5/16-18 USS x 1 SS	4
14	95.05-3	.Washer, Flat 5/16 SAE SS	9
15	NX-1118	.Plate, Jack Shaft Bearing Mount	1
16	55.FB16016-1	.Bearing, Flange Block 1"	2
17	NX-1165	.Shaft, Jack NX Snowblower	1
18	83.H16S	.Bushing, 1" Split 1/4" Key	1
19	83.2AK3016	.Pulley, 2AK 3.0" 1" Bore	1
20	83.BK85H	.Pulley, 8.5" H-Bush	1
21	90.0406	.Bolt, 1/4-20 USS x 3/4"	2
22	85.K0412	.Key, 1/4 X 1-1/2	2
23	81.A049*	.Belt, A49R	2
24	85.B0027	.Bushing, 1/2 ID X 5/8 OD X 5/8	2
25	41.0066	.Spring, Single Torsion LH	1
26	83.0042	.Pulley, Dbl Idler Flat 4 X 3/8	1
27	90.0616-3	.Bolt, 3/8-16 USS x 2 SS	1
28	90.0828	.Bolt, 1/2-13 USS x 3 1/2	1
29	85.SS15	.Set Screw, 5/16-18 x 5/16	1
30	00.0208	.Decal, Danger Auger Hazard (Serial # 01001-02510)	1
30	00.0630	.Decal, Entanglement Hazard Auger (Serial # 02511-)	1
31	NX-6105	.Arm, Belt Tension Idler	1
32	90.0406-3	.Bolt, 1/4-20 USS x 3/4 SS (Serial # 01001-01232)	1
32	90.0404-3	.Bolt, 1/4-20 USS x 1/2 SS (Serial # 01233-)	1
33	NX-1182	.Plate, Auger Drive Inner Cover (Serial # 01233-)	1
34	NX-1181	.Plate, Deep Snow Auger Blockoff	1
35	90.0406-3	.Bolt, 1/4-20 USS x 3/4 SS	3
36	NX-1178	.Plate, Auger Drive Inner Cover (Serial # 01001-01232)	1

*If snow blower is equipped with a deep snow (top auger) kit, refer to the deep snow kit illustrated drawing for auger drive belts.

PARTS

ILLUSTRATED DRAWING Fan Drive

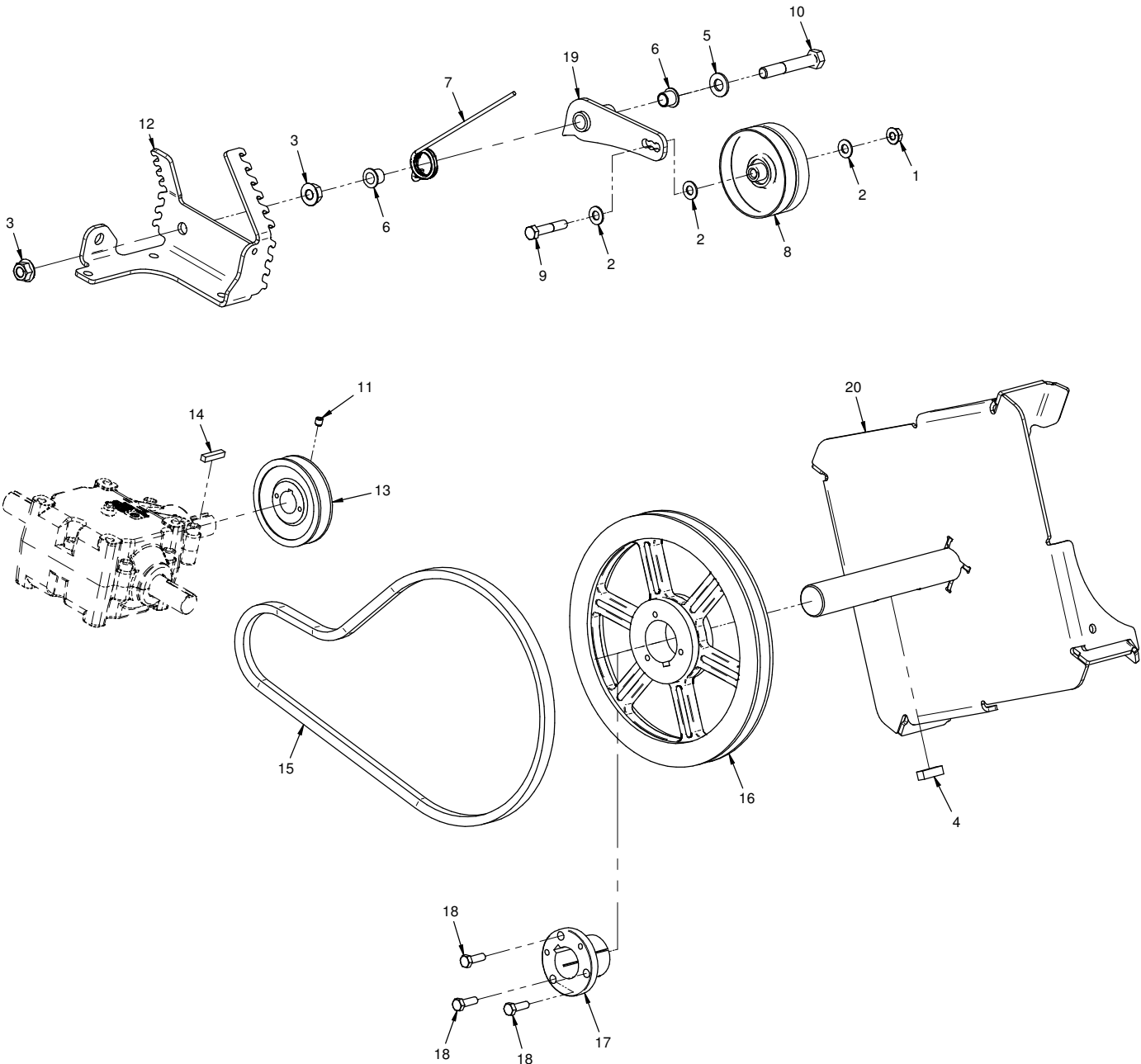

PARTS

Fan Drive

REF.	PART NO.	DESCRIPTION	QTY.
1	99.SF06-3	.Nut, SRF 3/8-16 USS Stainless	1
2	95.06-3	.Washer, Flat 3/8 SAE SS	3
3	99.SF08	.Nut, SRF 1/2-13 USS	2
4	85.K0610	.Key, 3/8 X 1-1/4	1
5	95.08	.Washer, Flat 1/2 SAE	1
6	85.B0027	.Bushing, 1/2 ID X 5/8 OD X 5/8	2
7	41.0066	.Spring, Single Torsion LH	1
8	83.0042	.Pulley, Dbl Idler Flat 4 X 3/8	1
9	90.0616-3	.Bolt, 3/8-16 USS x 2 SS	1
10	90.0828	.Bolt, 1/2-13 USS x 3-1/2	1
11	85.SS15	.Set Screw, 5/16-18 x 5/16	1
12	NX-1124	.Bracket, Belt Tensioner	1
13	83.BK4016	.Pulley, 4.0" 1" Bore	1
14	85.K0410	.Key, 1/4 X 1-1/4	1
15	81.B045	.Belt, B45	1
16	83.TB110	.Pulley, 11" P1-Bush (Serial # 01001-01662)	1
16	83.B110SDS	.Pulley, 11" SDS Bushing (Serial # 01663-)	1
17	83.P123	.Bushing, 1 7/16" P1 (Serial # 01001-01662)	1
17	83.SDS23	.Bushing, 1-7/16" SDS (Serial # 01663-)	1
18	90.0508	.Bolt, 5/16-18 USS x 1" (Serial # 01001-01662)	3
18	90.0410	.Bolt, 1/4-20 USS x 1 1/4 (Serial # 01663-)	3
19	NX-6105	.Arm, Belt Tension Idler	1
20	NX-6102	.Fan, Blower	1

PARTS

ILLUSTRATED DRAWING Fan Drive Covers & Adjustment Cover Belting

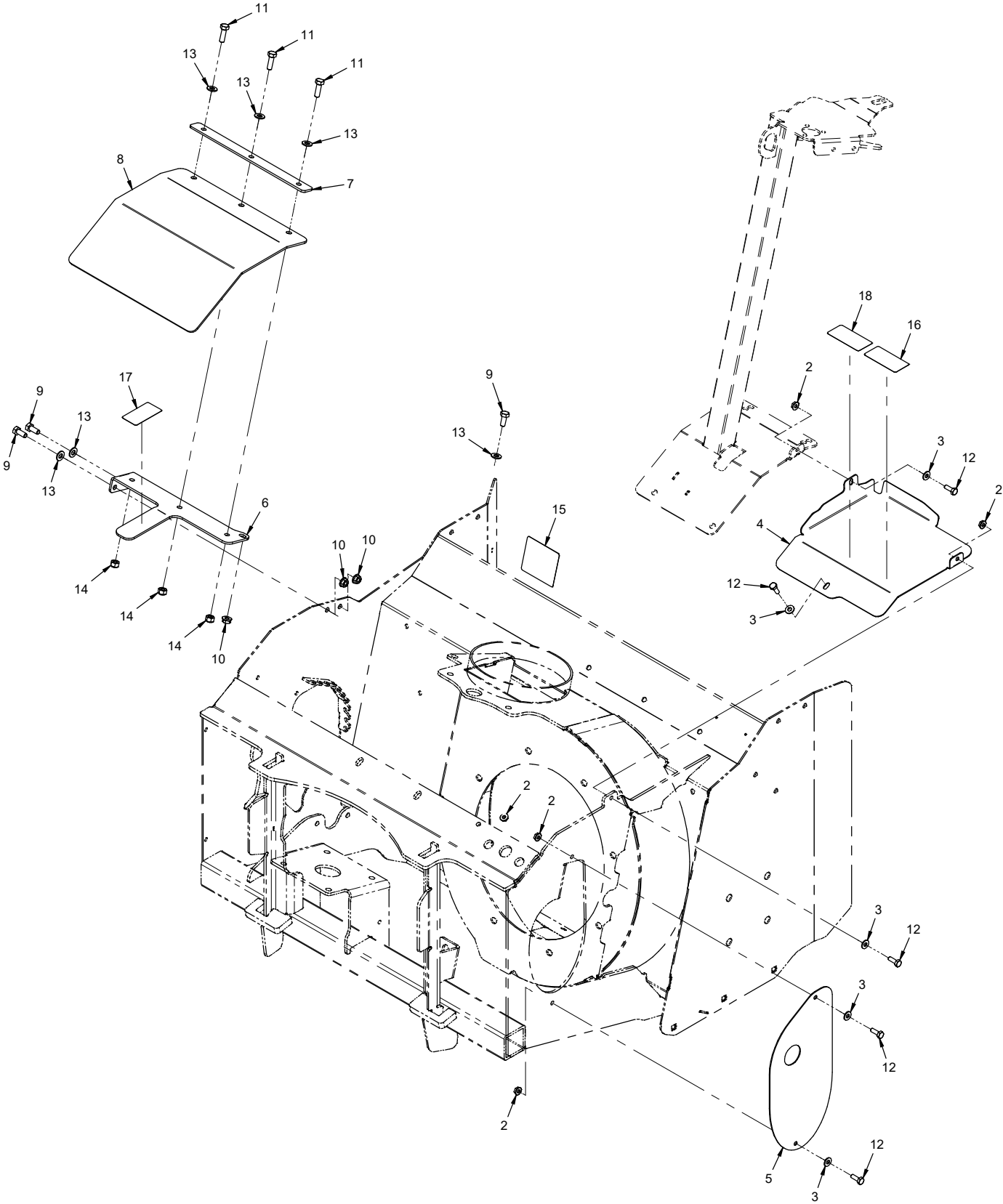

PARTS

Fan Drive Covers & Adjustment Cover Belting

REF.	PART NO.	DESCRIPTION	QTY.
2	99.SF04-3	.Nut, SRF 1/4-20 USS Stainless	5
3	95.04-3	.Washer, Flat 1/4 SAE SS	5
4	NX-1104	.Shield, Fan Drive Pulley Upper	1
5	NX-1101	.Shield, Fan Drive Pulley Side	1
6	NX-1138	.Bracket, Rubber Shield Support	1
7	NX-1139	.Plate, Rubber Shield Clamp	1
8	NX-1156	.Belting, Belt Adjustment Cover	1
9	90.0506-3	.Bolt, 5/16-18 USS x 3/4 SS	3
10	99.SF05-3	.Nut, SRF 5/16-18 USS Stainless	3
11	90.0508-3	.Bolt, 5/16-18 USS x 1 SS	3
12	90.0406-3	.Bolt, 1/4-20 USS x 3/4 SS	5
13	95.05-3	.Washer, Flat 5/16 SAE SS	6
14	99.A05N-3	.Locknut, Nylon 5/16-18 SS	3
15	00.0492	.Decal, Shield Missing (Serial # 01001-02510)	1
15	00.0625	.Decal, Shield Missing (Serial # 02511-)	1
16	00.0103	.Decal, Hazard - High Press. Fluid (Serial # 01001-02510)	1
16	00.0621	.Decal, High Pressure Fluid Hazard (Serial # 02511-)	1
17	00.0216	.Decal, Warning Moving Parts (Serial # 01001-02510)	1
17	00.0631	.Decal, Finger/Hand Entanglement (Serial # 02511-)	1
18	00.0122	.Decal, Thrown Object Hazard (Serial # 01001-02510)	1
18	00.0674	.Decal, Thrown Objects (Serial # 02511-)	1

PARTS

ILLUSTRATED DRAWING Discharge Chute Guard & Cleaning Tool

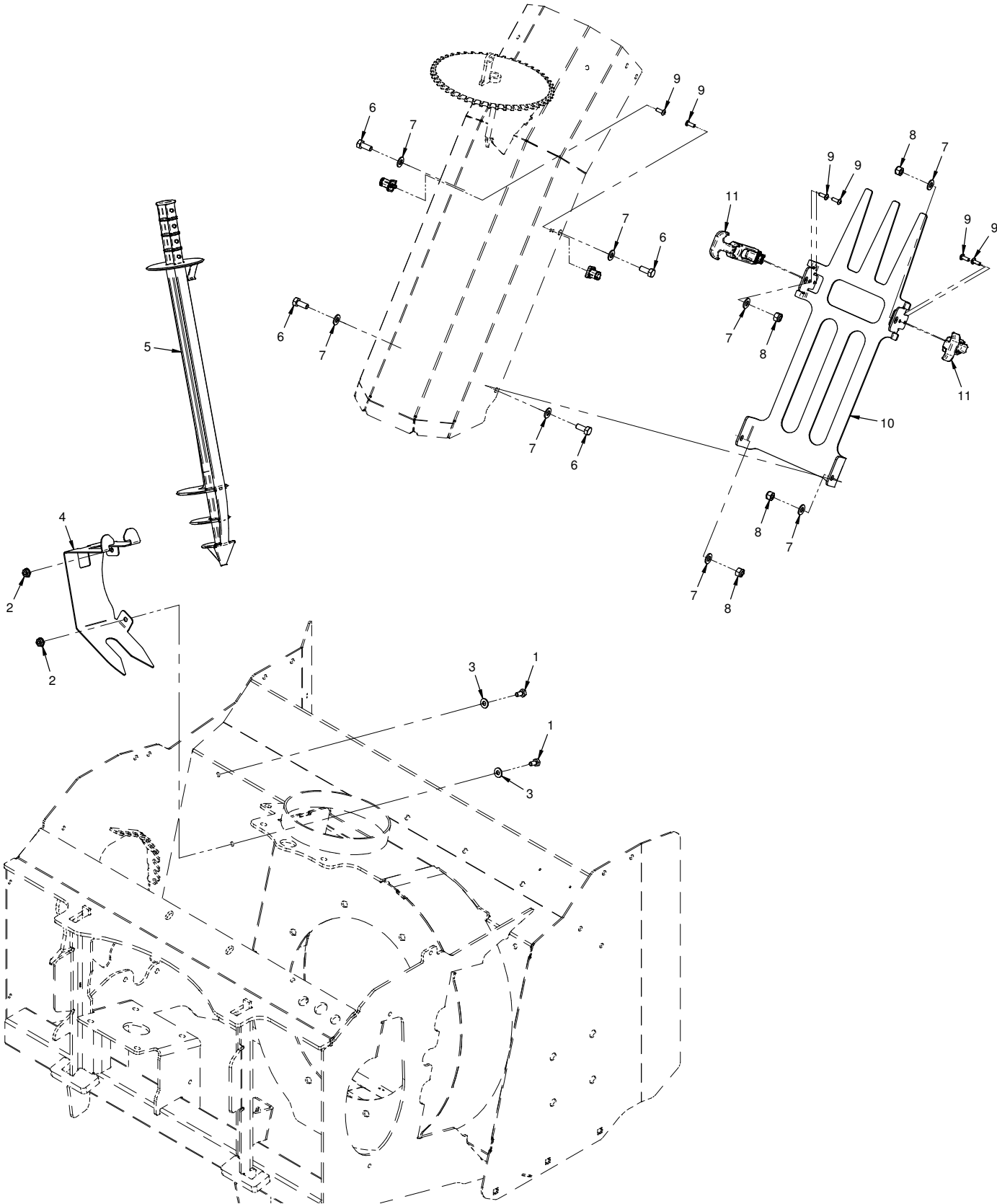

PARTS

Discharge Chute Guard & Cleaning Tool

REF.	PART NO.	DESCRIPTION	QTY.
1	90.0404-3	.Bolt, 1/4-20 USS x 1/2 SS	2
2	99.SF04-3	.Nut, SRF 1/4-20 USS Stainless	2
3	95.04-3	.Washer, Flat 1/4 SAE SS	2
4	NX-1105	.Bracket, Sno-Stik Holder	1
5	72.0023	.Tool, Chute Cleaning	1
6	90.0506-3	.Bolt, 5/16-18 USS x 3/4 SS	4
7	95.05-3	.Washer, Flat 5/16 SAE SS	8
8	99.A05N-3	.Locknut, Nylon 5/16-18 SS	4
9	99.K0148	.Machine Screw, #10-24 X 1/2 SS	6
10	60.1060	.Guard, Chute Discharge	1
11	47.0127	.Latch, Rubber Draw T-Handle	2

PARTS

ILLUSTRATED DRAWING 70.8192 12 Volt Actuator Kit

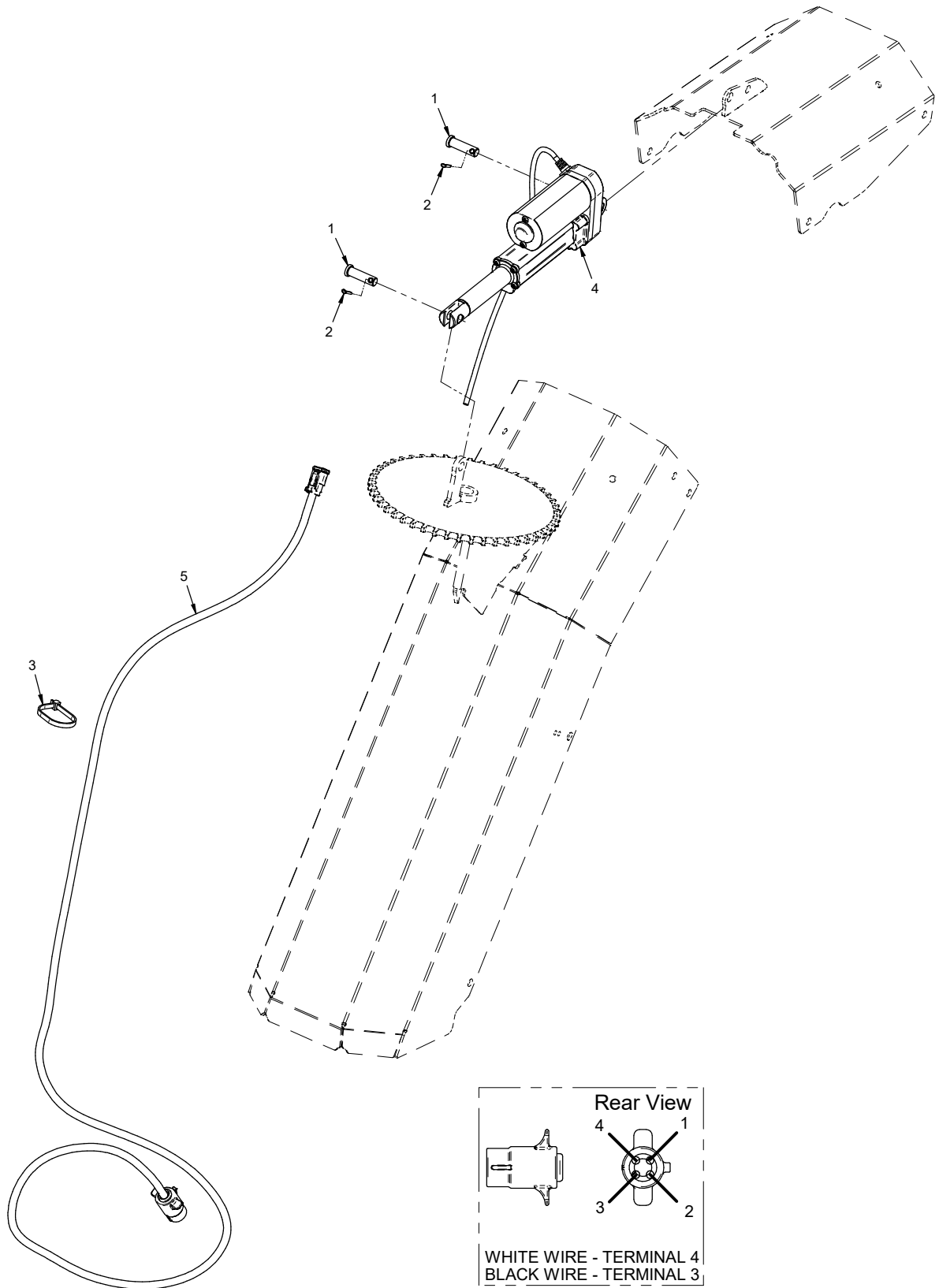

PARTS

70.8192 12 Volt Actuator Kit

REF.	PART NO.	DESCRIPTION	QTY.
1	03.0610	Clevis Pin, 3/8 X 1-1/4 ZP	2
2	02.CP0306	Cotter Pin, 3/32 X 3/4	2
3	30.0037	Tyton Tie, #50 .18 x 8 Black	5
4	37.0067	Actuator, 12V	1
5	32.0211	Harness, Wire NX Actuator	1

PARTS

ILLUSTRATED DRAWING 70.8188 Deep Snow Kit

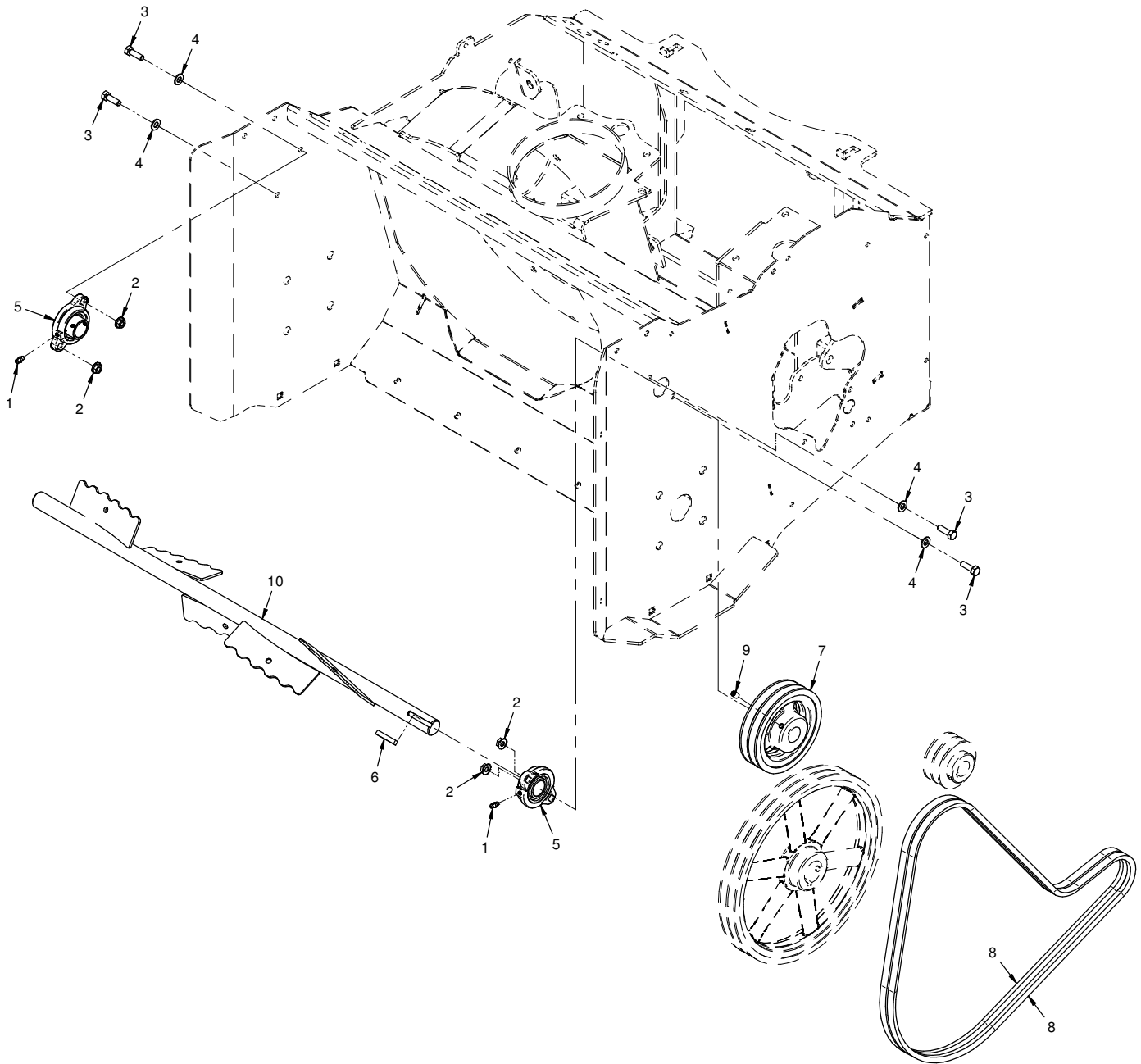

PARTS

70.8188 Deep Snow Kit

REF.	PART NO.	DESCRIPTION	QTY.
1	29.GF0001	.Grease Ftg, 1/4 SAE ST	2
2	99.SF05-3	.Nut, SRF 5/16-18 USS Stainless	4
3	90.0508-3	.Bolt, 5/16-18 USS x 1 SS	4
4	95.05-3	.Washer, Flat 5/16 SAE SS	4
5	55.FB16016-1	.Bearing, Flange Block 1"	2
6	85.K0412	.Key, 1/4 X 1-1/2	1
7	83.2AK5616	.Pulley, 2AK 5.6" 1" Bore	1
8	81.A058	.Belt, A58	2
9	85.SS16	.Set Screw, 5/16-18 x 1/2	1
10	NX-6104	.Auger, Top NX340	1