

Parts Manual

KY400

Trencher



Revised 10/07/24
09.20064 Rev. 01



500 Venture Drive
Orrville Oh 44667
www.ventrac.com

Serial Number Description



Notes

- If any component requires replacement, use only original Ventrac replacement parts.
- When ordering new components, be sure to order all required safety decals. All current safety decals must be affixed to the replacement components prior to installation of the component.

TABLE OF CONTENTS

PARTS	PAGE 4
Main Frame, Boom Frame, & Shields	4
Trencher Drivetrain	6
Trencher Boom (Serial # 1001-1224).....	8
Trencher Boom (Serial # 1225-).....	10
Trencher Chain	12
Hydraulic Boom Lift	14

PARTS

ILLUSTRATED DRAWING Main Frame, Boom Frame, & Shields

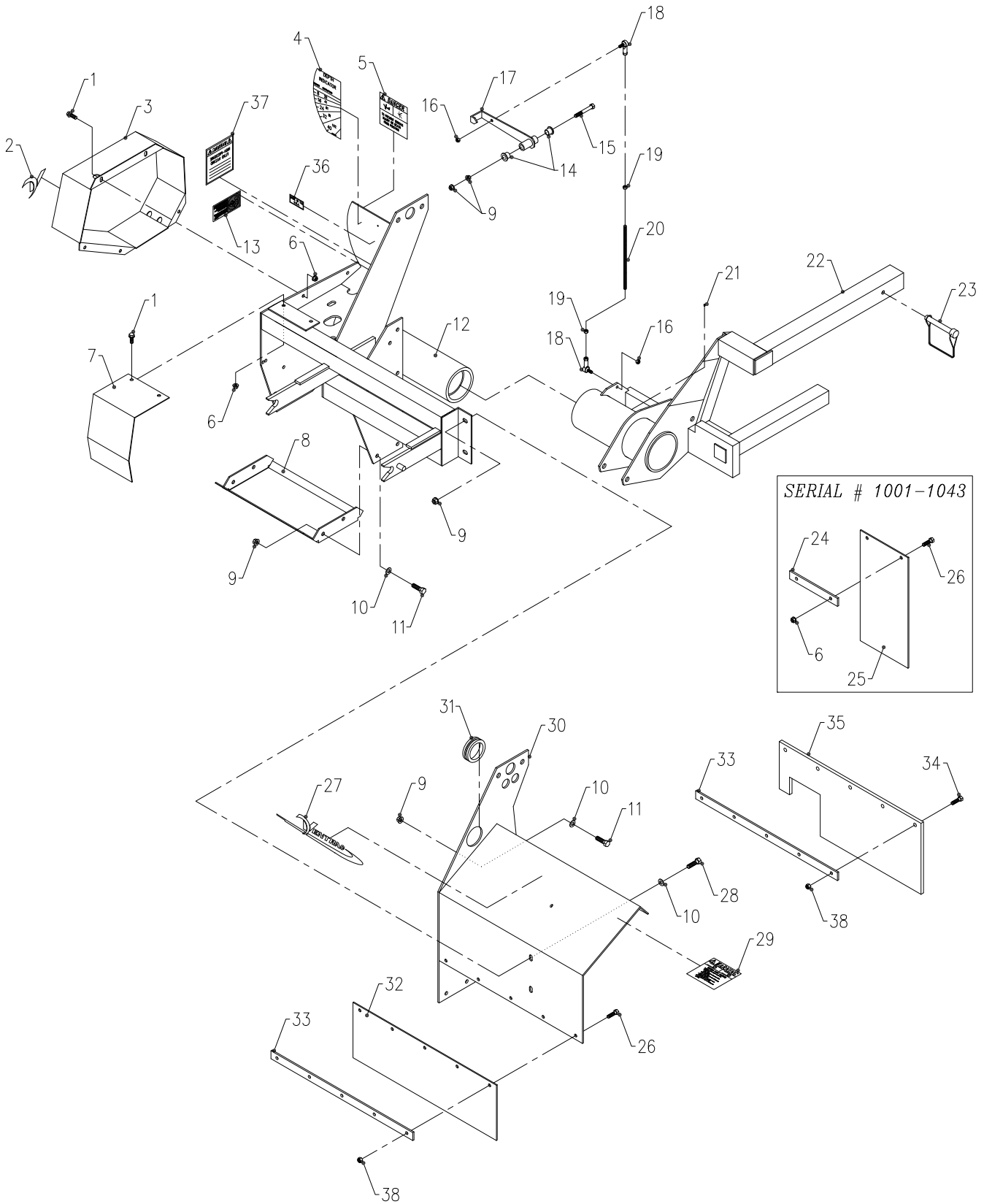

PARTS

Main Frame, Boom Frame, & Shields

REF.	PART NO.	DESCRIPTION	QTY.
1	99.SF0506	.BOLT, SRF 5/16-18 USS X 3/4	8
2	00.0192	.DECAL, V-DECAL DIE CUT BLUE	1
3	60.0834	.SHIELD, CHAIN	1
4	00.0186	.DECAL, DEPTH INDICATOR KY	1
5	00.0102	.DECAL, DANGER-PINCHING HAZARD (Serial # 1001-2093)	1
5	00.0620	.DECAL, PINCHING OR CRUSHING HAZARD (Serial # 2094 -)	1
6	99.SF05	.NUT, SRF 5/16-18 USS	7
7	60.0833	.SHIELD, BELT DRIVE	1
8	60.0835	.PLATE, FOOT PAD	1
9	99.SF06	.NUT, SRF 3/8-16 USS	11
10	95.06	.WASHER, FLAT 3/8 SAE	11
11	90.0608	.BOLT, 3/8-16 USS X 1	7
12	62.0927	.FRAME, MAIN	1
13	00.0217	.DECAL, WARNING READ OWNERS MAN (Serial # 1001-2093)	1
13	00.0619	.DECAL, READ OPERATOR'S MANUAL (Serial # 2094 -)	1
14	85.B0068	.BUSHING, 3/8 X 1/2 OD X 1/2 LG	2
15	90.0618	.BOLT, 3/8-16 USS X 2 1/4	1
16	99.A04NF	.LOCKNUT, STOVER 1/4-28 SAE	2
17	40.0302	.ARM, DEPTH GAUGE POINTER	1
18	43.004S	.ROD END, 1/4 SPHERICAL W/STUD	2
19	93.04	.NUT, 1/4-28 SAE	2
20	42.0449	.ROD, THREADED 1/4-28 X 9L	1
21	29.GF0001	.GREASE FTG, 1/4 SAE ST	1
22	62.0928	.FRAME, BOOM/DIGGER	1
23	03.0003	.PIN, SAFETY SNAP 3/8 X 2 1/2	1
24	64.0992	.CLAMP, BELTING 7" LONG	1
25	44.0198	.FLAP, COVER KY	1
26	90.0506	.BOLT, 5/16-18 USS X 3/4	7
27	00.0189	.DECAL, VENTRAC ORBITAL (Serial # 1001-2453)	1
27	00.0383	.DECAL, VENTRAC (Serial # 2454-)	1
28	90.0606	.BOLT, 3/8-16 USS X 3/4	2
29	00.0101	.DECAL, HAZARD-MOVING PART (Serial # 1001-2093)	1
29	00.0704	.DECAL, TRENCHER HAZARD (Serial # 2094 -)	1
30	60.0832	.FRAME, AUGER SHROUD	1
31	05.0073	.GROMMET, 2 ID, 2-3/4 OD 9/16 T	1
32	44.0197	.BELTING, LOWER DIRT	1
33	64.0991	.CLAMP, BELTING 1" X 20-3/4L	2
34	90.0508	.BOLT, 5/16-18 USS X 1	5
35	44.0208	.BELTING, AUGER AND CHAIN	1
36	00.0770	.DECAL, MADE IN USA	1
37	00.0103	.DECAL, HAZARD-HIGH PRESS.FLUID (Serial # 1001-2093)	1
37	00.0621	.DECAL, HIGH PRESSURE FLUID HAZARD (Serial # 2094 -)	1
38	99.A05	.LOCKNUT, STOVER 5/16-18 USS	10

PARTS

ILLUSTRATED DRAWING Trencher Drivetrain

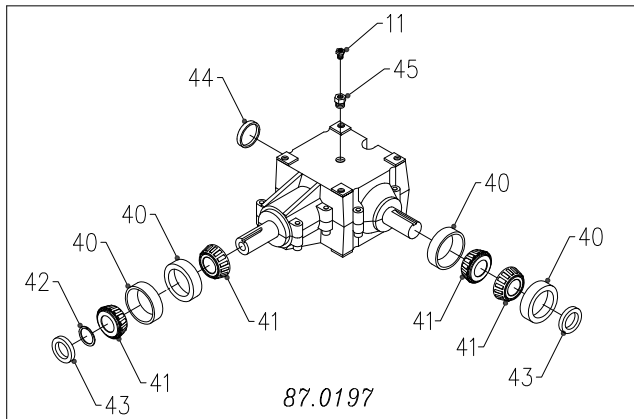
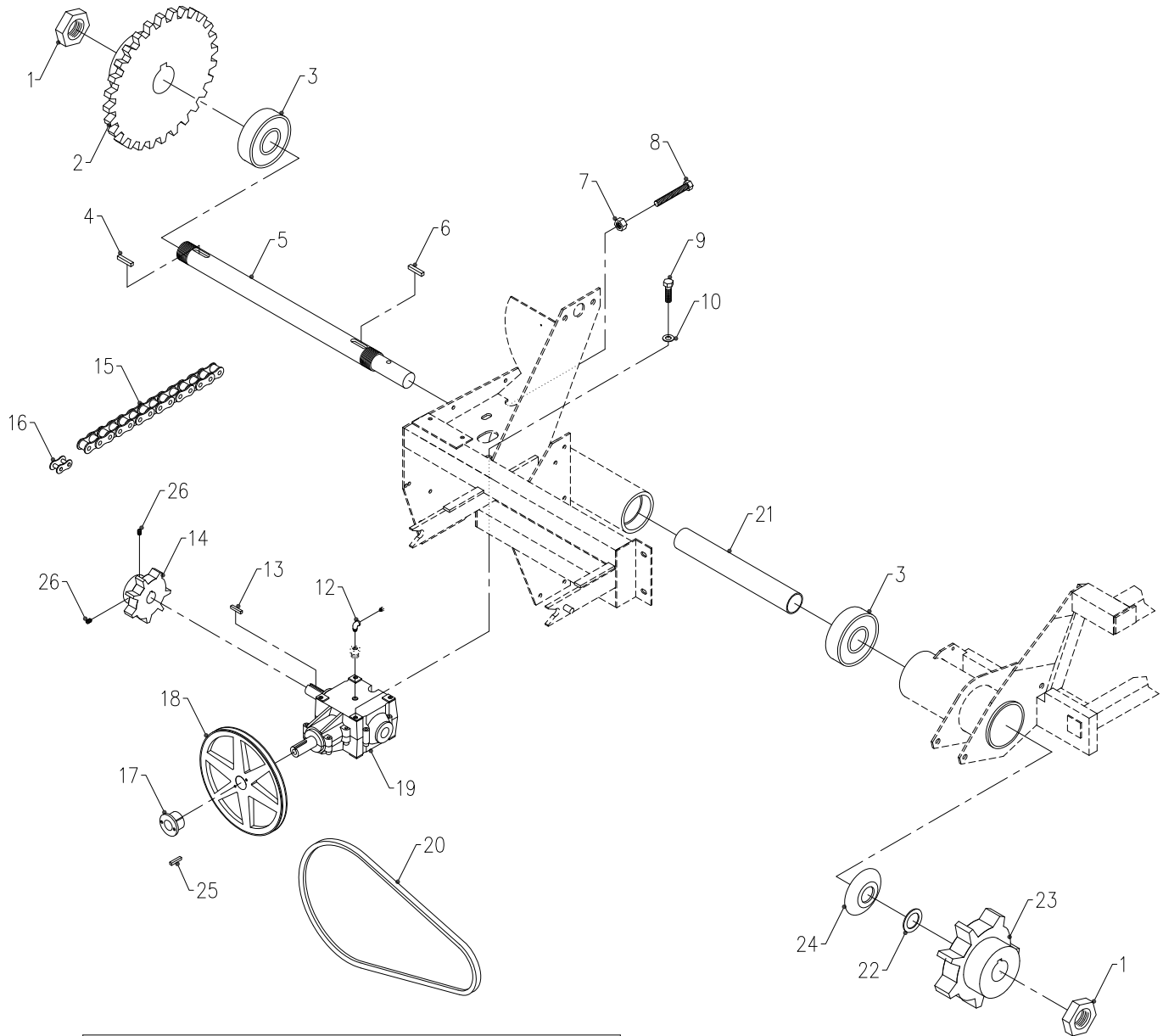

PARTS

Trencher Drivetrain

REF.	PART NO.	DESCRIPTION	QTY.
1	99.E0065	NUT, JAM 1 3/4 SAE ZP	2
2	83.H8028	SPROCKET, #80 28-T 1-3/4 BORE	1
3	55.0050	BEARING, 1 3/4 ID X 3.347 OD	2
4	85.K0610	KEY, 3/8 X 1 1/4	1
5	80.0323	SHAFT, MAIN POWER KY400	1
6	85.K0810	KEY, 1/2 X 1 1/4	1
<hr/>			
7	92.08	NUT, 1/2-13 USS	1
8	90.0832-2	BOLT, 1/2-13 USS X 4 ALL THRD	1
9	90.0808	BOLT, 1/2-13 USS X 1	4
10	95.08	WASHER, FLAT 1/2 SAE	4
11	29.0090	PIPE, BREATHER PLUG 1/8	1
12	29.S9002G	PIPE, STREET 90 ELBOW 1/8 GALV	1
<hr/>			
13	85.K0410	KEY, 1/4 X 1 1/4	1
14	83.H800920	SPROCKET,#80 9-T HRD 1-1/4 BOR	1
15	81.0140	CHAIN, ROLLER #80 X 33.875"	1
16	81.0059	LINK, CONN #80	1
17	83.H20	BUSHING, 1 1/4" H	1
18	83.BK80H	PULLEY, 8" H-BUSH	1
<hr/>			
19	87.0197	GEARBOX, SUPERIOR KY400	1
20	81.B053	BELT, B53	1
21	64.0993	TUBE, BEARING SPACER	1
22	99.B0019	WASHER, MACH 1 3/4 10 GA	3*
22	99.B0039	WASHER, MACH 1 3/4 X 18GA	2*
23	83.0044	SPROCKET, DRIVE 1.654 PITCH (Serial # 1001-1042)	1
23	83.0049	SPROCKET, DRIVE 1.654 PITCH N* (Serial # 1043-)	1
<hr/>			
24	60.0881	SHIELD, BEARING	1
25	85.K030410	KEY, 3/16 X 1/4 X 1-1/4	1
26	85.SS15	SET SCREW, 5/16-18 X 5/16	2
40	55.0078	BEARING, CUP 2.717	4
41	55.0077	BEARING, CONE 1.375	4
42	04.0027	RETAINING RING, EXT 1.375 SHFT.	1
<hr/>			
43	89.0082	SEAL, 1.375-2.00-313	2
44	89.0083	SEAL, END CAP 2.00-312	1
45	29.B0208G	PIPE, BUSHING 1/8 X 1/2 GALV	1

*as required

PARTS

ILLUSTRATED DRAWING Trencher Boom (Serial # 1001-1224)

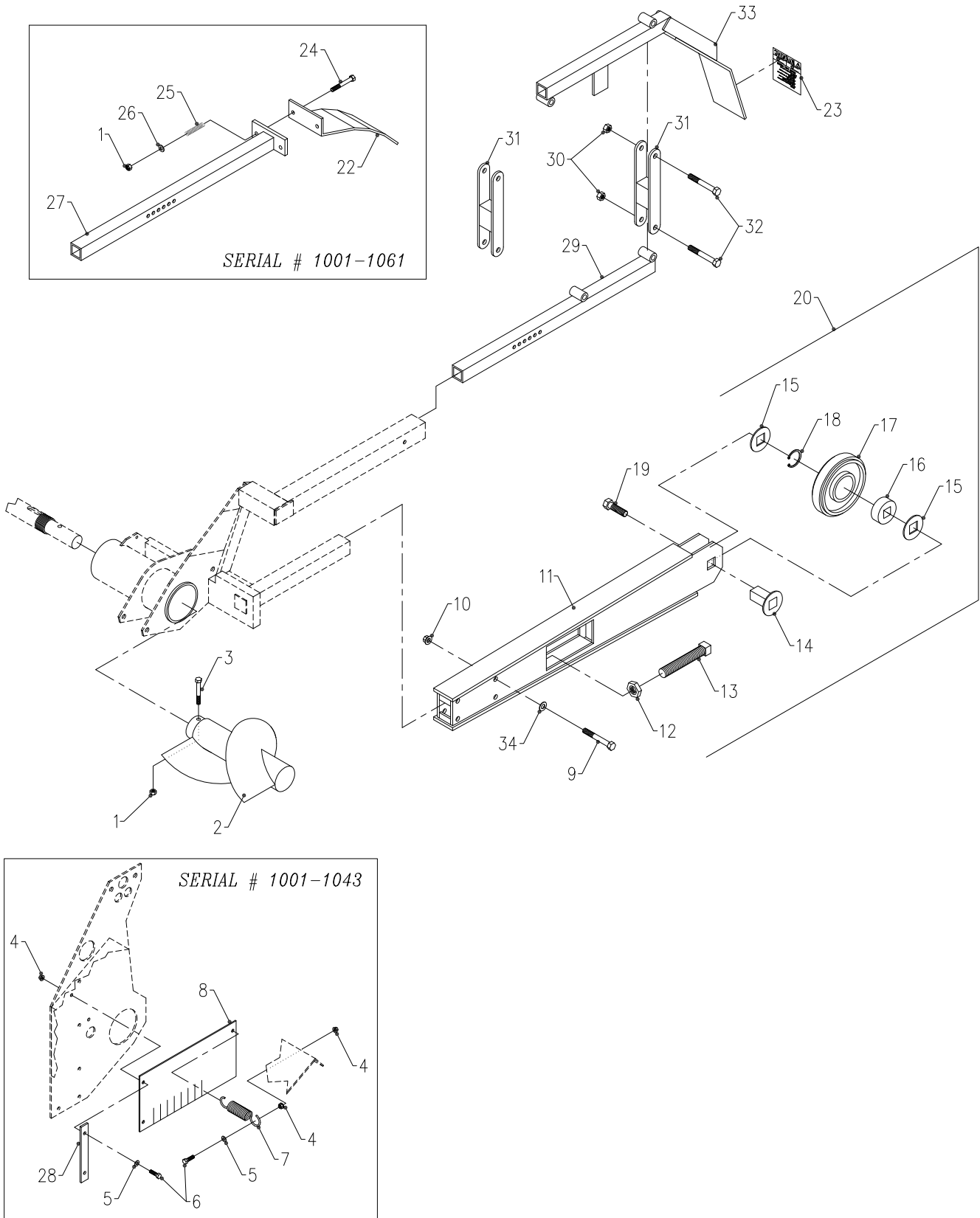

PARTS

Trencher Boom (Serial # 1001-1224)

REF.	PART NO.	DESCRIPTION	QTY.
1	99.A06	LOCKNUT, STOVER 3/8-16 USS	3
2	80.0322	AUGER, DIRT DISCHARGE	1
3	90.0624	BOLT, 3/8-16 USS X 3	1
4	99.SF05	NUT, SRF 5/16-18 USS	4
5	94.05	WASHER, FLAT 5/16 USS	1
6	90.0508	BOLT, 5/16-18 USS X 1	3
7	41.0071	SPRING, EXT 3/4 X 4-1/2 OALG (Serial # 1001-1042)	1
8	44.0199	FLAP, SPRING LOADED KY (Serial # 1001-1042)	1
9	99.K0093	BOLT, 1/2-13 X 3-1/2 GRD. 8	4
10	99.E0068	NUT, FLANGE 1/2-13 GRD. 8	4
11	87.0198-1	BOOM, ROLLER 36" KY	1
12	99.E0066	NUT, JAM 1 USS	1
13	99.K0092	BOLT, 1"-8 X 6" SQ HEAD	1
14	80.0325	SHAFT, SQ. IDLER	1
15	85.B0076	BUSHING, 2 1/2 OD X 1/8 THK	2
16	55.0051	BEARING, 1-1/8" SQ ID	1
17	50.0169	ROLLER, END 6-3/4 OD BALLANTIN	1
18	04.0022	SNAP RING, EXT BALLANTINE	1
19	99.K0091	BOLT, 3/4-10 X 1-1/2 GRD. 8	1
20	87.0198	BOOM, ROLLER ASM 36" KY	1
22	60.0836	FINGER, DRIBBLE (Serial # 1001-1061)	1
23	00.0101	DECAL, HAZARD-MOVING PART	1
24	90.0628	BOLT, 3/8-16 USS X 3 1/2	2
25	41.0072	SPRING, COMP. 3/4 X 2 1/2" LG	2
26	95.06	WASHER, FLAT 3/8 SAE	2
27	62.0929	ARM, DRIBBLE KY (Serial # 1001-1061)	1
28	64.0992	CLAMP, BELTING 7" LONG (Serial # 1001-1042)	1
29	62.1013	ARM, CRUMB CLEANER (Serial # 1062-)	1
30	92.08	NUT, 1/2-13 USS	4
31	42.0468	LINK, PIVOT CRUMB CLEANER (Serial # 1062-)	2
32	90.0826	BOLT, 1/2-13 USS X 3 1/4	4
33	60.0886	SHOE, CRUMB CLEANER (Serial # 1062-)	1
34	94.08	WASHER, FLAT 1/2 USS	4

PARTS

ILLUSTRATED DRAWING Trencher Boom (Serial # 1225-)

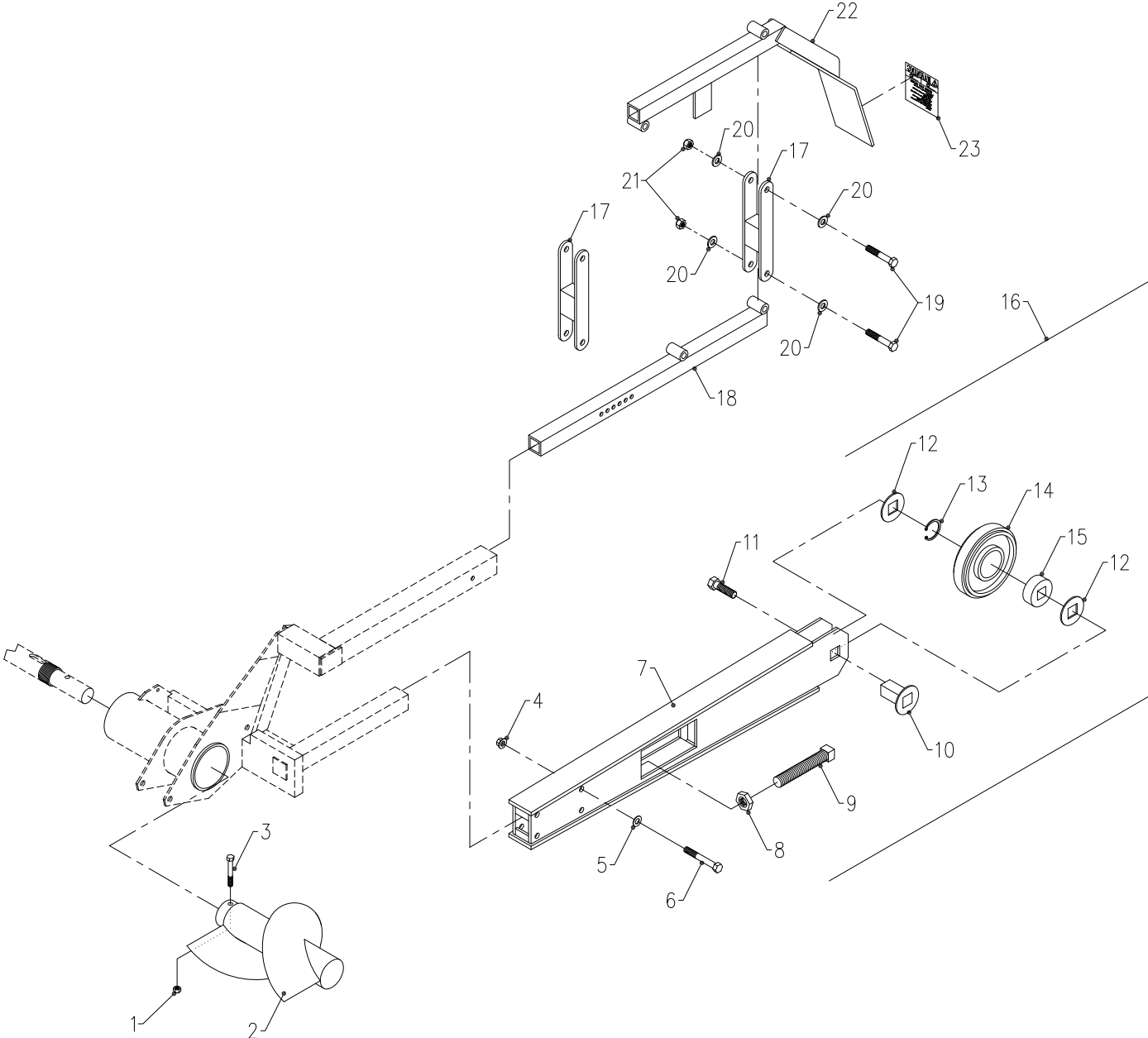

PARTS

Trencher Boom (Serial # 1225-)

REF.	PART NO.	DESCRIPTION	QTY.
1	99.A06	.LOCKNUT, STOVER 3/8-16 USS	3
2	80.0322	.AUGER, DIRT DISCHARGE	1
3	90.0624	.BOLT, 3/8-16 USS X 3	1
4	99.E0068	.NUT, FLANGE 1/2-13 GRD. 8	4
5	94.08	.WASHER, FLAT 1/2 USS	4
6	99.K0093	.BOLT, 1/2-13 X 3-1/2 GRD. 8	4
7	87.0198-1	.BOOM, ROLLER 36" KY	1
8	99.E0066	.NUT, JAM 1 USS	1
9	99.K0092	.BOLT, 1"-8 X 6" SQ HEAD	1
10	80.0325	.SHAFT, SQ. IDLER	1
11	99.K0091	.BOLT, 3/4-10 X 1-1/2 GRD. 8	1
12	85.B0076	.BUSHING, 2 1/2 OD X 1/8 THK	2
13	04.0022	.SNAP RING, EXT BALLANTINE	1
14	50.0169	.ROLLER, END 6-3/4 OD BALLANTIN	1
15	55.0051	.BEARING, 1-1/8" SQ ID	1
16	87.0198	.BOOM, ROLLER ASM 36" KY	1
17	42.0519	.LINK, PIVOT CRUMB CLEANER	2
18	62.1013	.ARM, CRUMB CLEANER	1
19	90.0824	.BOLT, 1/2-13 USS X 3	4
20	95.08	.WASHER, FLAT 1/2 SAE	8
21	99.A08	.LOCKNUT, STOVER 1/2-13 USS	4
22	60.0886	.SHOE, CRUMB CLEANER	1
23	00.0101	.DECAL, HAZARD-MOVING PART (Serial # 1225-2093)	1
23	00.0704	.DECAL, TRENCHER HAZARD (Serial # 2094 -)	1

PARTS

ILLUSTRATED DRAWING Trencher Chain

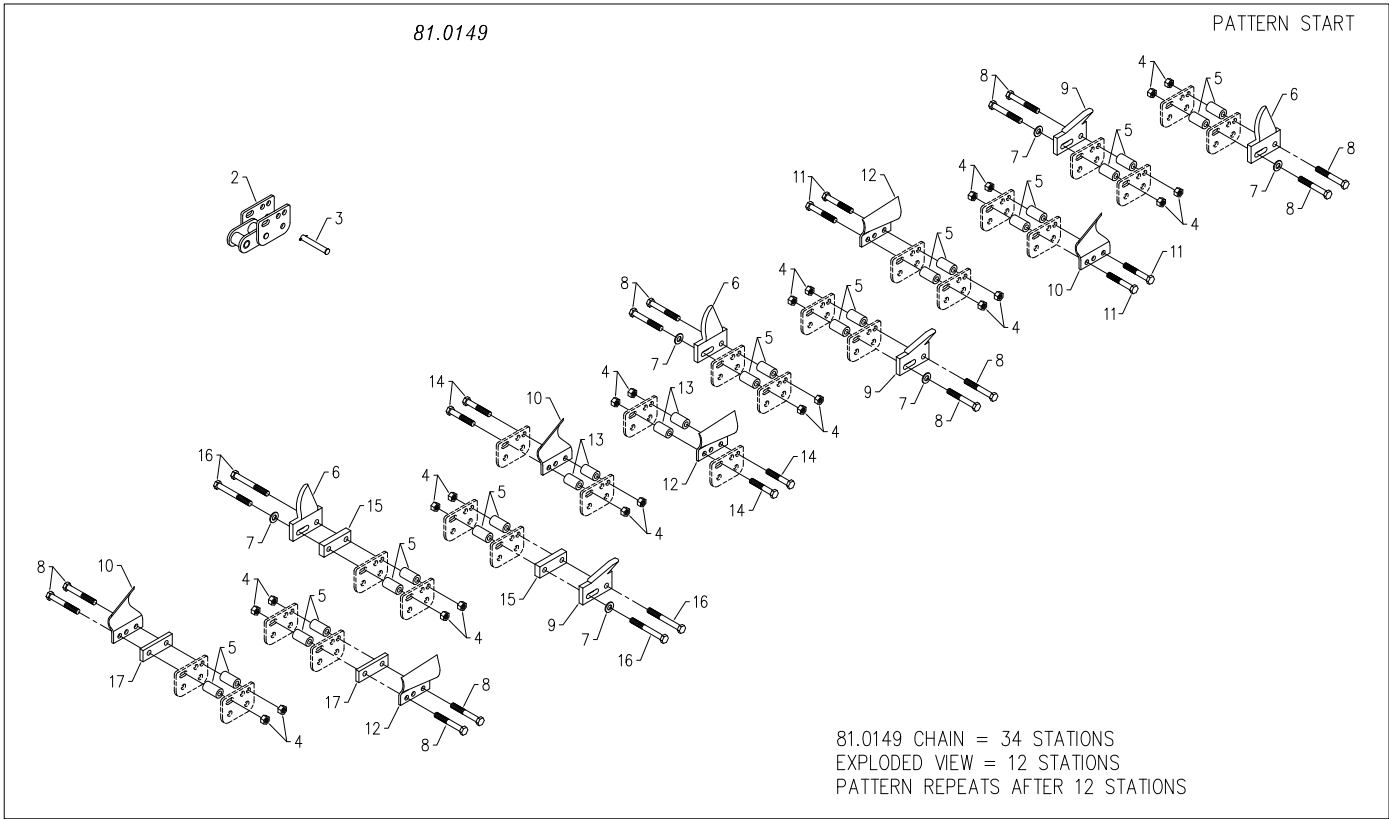
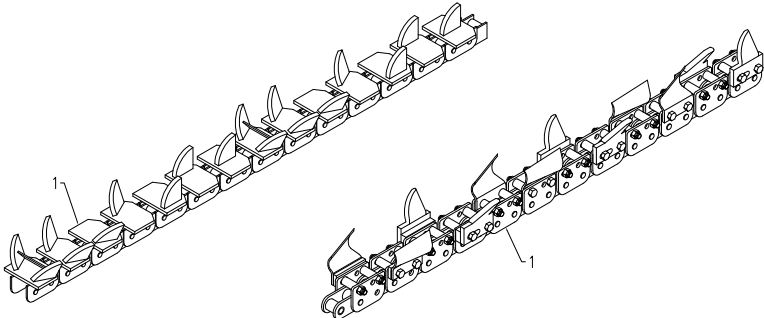

PARTS

Trencher Chain

REF.	PART NO.	DESCRIPTION	QTY.
1	81.0141	.CHAIN, ASM 5-1/2 X 36" LG (Serial # 1001-1042)	1
1	81.0149	.CHAIN, ASM 5.5" X 34 STATIONS (Serial # 1043-)	1
2	81.0152	.CHAIN, LINK REPAIR KIT	-
3	81.0151	.CHAIN, PIN & KEEPER CONNECTOR	-
4	99.A06NFC-8	.LOCKNUT, 3/8-24 GRADE 8 CENTER	68
5	81.0149-1	.SPACER, TUBE 1-3/8" LONG	56
6	79.0077	.TOOTH, SHARK - LEFT HAND	9
7	95.06	.WASHER, FLAT 3/8 SAE	18
8	91.0622-8	.BOLT, 3/8-24 X 2-3/4 GRADE 8	32
9	79.0076	.TOOTH, SHARK - RIGHT HAND	9
10	79.0075	.TOOTH, CUP - LEFT HAND	8
11	91.0620-8	.BOLT, 3/8-24 X 2-1/2 GRADE 8	12
12	79.0074	.TOOTH, CUP - RIGHT HAND	8
13	81.0149-2	.SPACER, TUBE 1-1/4" LONG	12
14	91.0618-8	.BOLT, 3/8-24 X 2-1/4 GRADE 8	12
15	81.0149-3	.SPACER, FLAT 1/2" THICK	6
16	91.0626-8	.BOLT, 3/8-24 X 3-1/4 GRADE 8	12
17	81.0149-4	.SPACER, FLAT 5/16" THICK	6

PARTS

ILLUSTRATED DRAWING Hydraulic Boom Lift

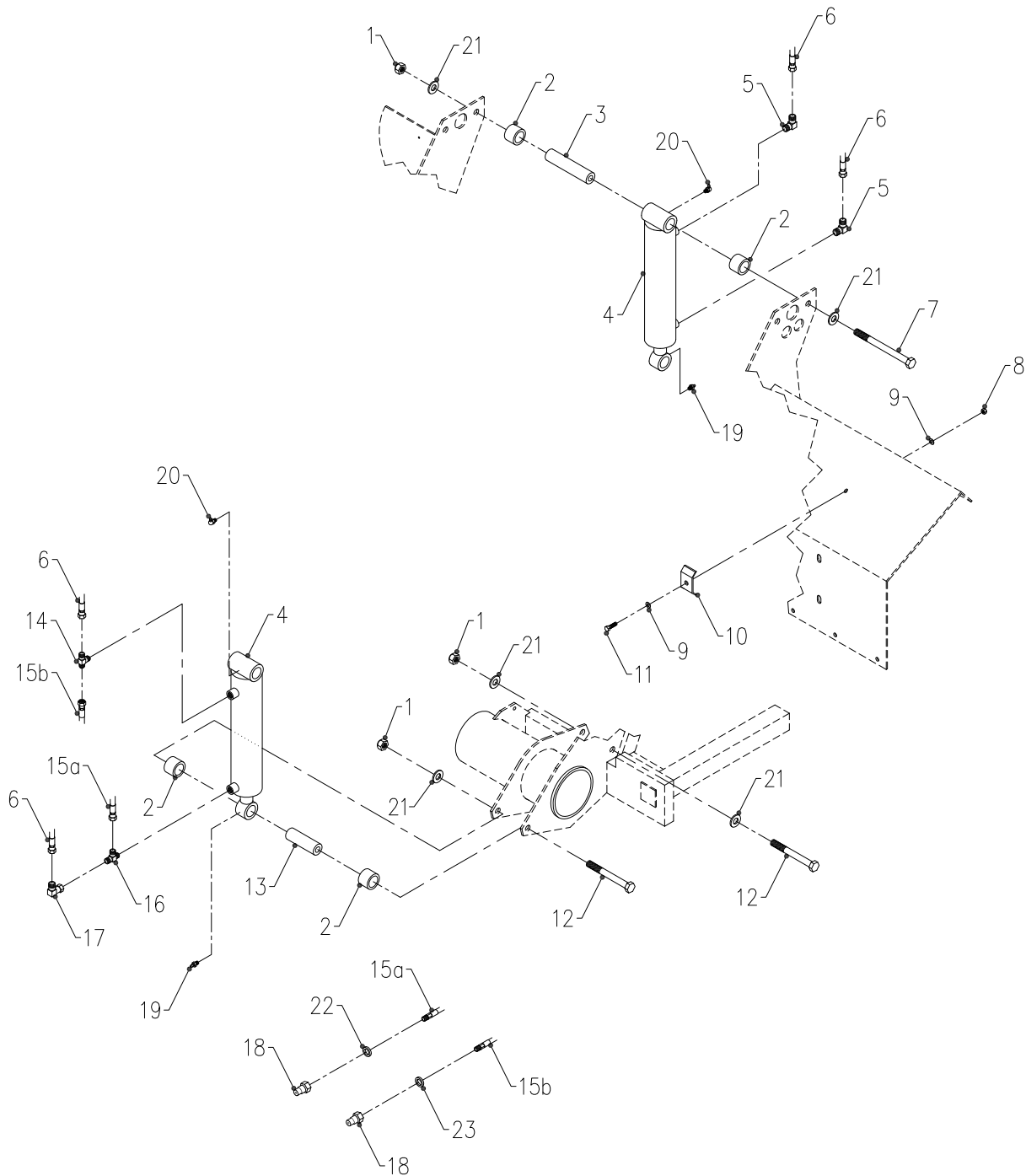

PARTS

Hydraulic Boom Lift

REF.	PART NO.	DESCRIPTION	QTY.
1	99.A08	.LOCKNUT, STOVER 1/2-13 USS	4
2	64.0996	.PIPE, 1" SCH 40 X 1"L	8
3	64.0995	.BUSHING, 1/2 X 1 X 4-5/8	2
4	23.0103	.CYLINDER, 2 X 8 -1" ROD (Serial # 1001-1042)	2
4	23.0128	.CYLINDER, 2" X 8" LIFT (Serial # 1043-)	2
5	25.2501-06-04	.FITTING, 90 ME 3/8 X 1/4 (Serial # 1001-1042)	2
5	25.6801-06-06	.FITTING, 90 ME 3/8 X 3/8 (Serial # 1043-)	2
6	20.0162	.HOSE, 1/4X24.00 SAE 100R17AR	2
7	90.0848	.BOLT, 1/2-13 USS X 6	2
8	99.A04	.LOCKNUT, STOVER 1/4-20 USS	1
9	95.04	.WASHER, FLAT 1/4 SAE	2
10	64.0673	.CLAMP, HYDRAULIC HOSE	1
11	90.0408	.BOLT, 1/4-20 USS X 1	1
12	90.0836	.BOLT, 1/2-13 USS X 4 1/2	2
13	64.0994	.BUSHING, 1/2 X 1 X 3-1/8	2
14	25.2601-6-6-4	.FITTING, M TEE 3/8 X 3/8 X 1/4 (Serial # 1001-1042)	1
14	25.6803-6-6-6	.FITTING, M TEE 3/8 X 3/8 X 3/8 (Serial # 1043-)	1
15	20.0140	.HOSE, 1/4X53.00 SAE 100R17 AR	2
16	25.2605-6-4-6	.FITTING, M TEE 3/8 X 1/4 X 3/8 (Serial # 1001-1042)	1
16	25.6804-6-6-6	.FITTING, M TEE 3/8 X 3/8 X 3/8 (Serial # 1043-)	1
17	25.6500-06-06	.FITTING, 90 MFE 3/8 X 3/8	1
18	23.0104	.COUPLER, QUICK MALE 1/4	2
19	29.GF0001	.GREASE FTG, 1/4 SAE ST	2
20	29.GF0002	.GREASE FTG, 1/4 SAE 90	2
21	95.08	.WASHER, FLAT 1/2 SAE	7
22	05.0117	.WASHER, .544ID X .817 X.14 YEL	1
23	05.0116	.WASHER, .544ID X .817 X.14 RED	1