

Parts Manual

4500P

Serial Number 4500P-AJ01001 --



Revised 08/11/23
09.20021 Rev. 34



500 Venture Drive
Orrville Oh 44667
www.ventrac.com



Visit ventrac.com/manuals for the latest version of this parts manual.

A downloadable operator's manual is also available.

Serial Number Description

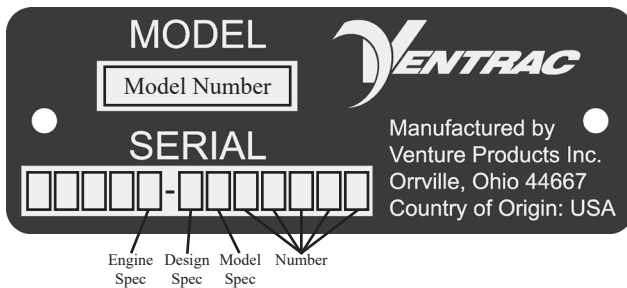

Engine

P KAWASAKI 31 HP FD851D DFI GAS LC

Notes

- If any component requires replacement, use only original Ventrac replacement parts.
- When ordering new components, be sure to order all required safety decals. All current safety decals must be affixed to the replacement components prior to installation of the component.

TABLE OF CONTENTS

ELECTRICAL	PAGE 7
Wiring Diagram Reference Key.....	7
Wiring Diagram - Rear Harness.....	8
Wiring Diagram - Front Harness.....	9
Wiring Diagram - Engine Harness.....	10
Wiring Diagram - Optional 30.0219 4-Pin Female Socket & 30.0218 4-Pin Male Plug.....	11
Tractor Control Module.....	12
Battery, Power Cables, & Ground Cables.....	14
Front Fuse Panel.....	16
Rear Fuse Panel.....	18
Power Relay Module.....	20
RPM Sensor.....	22
Speedometer Sensor.....	24
HYDRAULICS, AXLES, & WHEELS	PAGE 26
Hydraulic Diagram.....	26
O-Ring Chart.....	28
Fitting Chart.....	28
Hydraulic Oil Tank.....	32
Hydraulic Steering System.....	34
Front Hitch Hydraulic Lift.....	36
Auxiliary Hydraulic Quick Couplers.....	38
Front Hydraulic Motor Mount & Fittings.....	40
Rear Hydraulic Motor Mount & Fittings.....	42
Hydraulic Pump Mount & Fittings.....	44
Hydraulic Oil Cooler & Fan.....	46
Hydraulic Drive Circuit Hoses.....	48
Pump Supply Line & Main Hydraulic Filter.....	50
Hydraulic Implement Circuit Supply & Return.....	52
Front Transaxle & Wheels.....	54
Rear Transaxle & Wheels.....	56
Model 2600 Transaxle (51.0020/51.0087).....	58
Model 15 Hydraulic Motor (21.0081).....	60
Model 15 Hydraulic Pump (21.0080).....	62
ENGINES	PAGE 64
4500P Kawasaki Engine.....	64
4500P Kawasaki Engine Mount.....	66
4500P Kawasaki PTO Clutch.....	68
4500P Kawasaki Drive Shaft & Pump.....	70
4500P Kawasaki Muffler.....	72
4500P Kawasaki Cooling System.....	74
4500P Kawasaki Air Intake.....	76
4500P Kawasaki Fuel System.....	78

TABLE OF CONTENTS

FRAMES / SHEET METAL	PAGE 80
Lower Rear Frame	80
Seat Box & Upper Rear Frame	82
Left Seat Box Panels.....	84
Right Seat Box Panels	86
Tool Box Lid & Liner Panels	88
Roll Bar	90
Standard Rear Hitch.....	92
Rear Fenders & Battery Compartment.....	94
Standard Seat Assembly.....	96
Front Frame, Frame Connector Bracket, Hose Retainer	98
Front Fenders & Foot Pegs.....	100
Center Pivot & Connector Link.....	102
Front Hitch.....	104
Hood, Grill, & Headlights.....	106
Dash, Dash Brackets, Decals, & Switches.....	108
 CONTROLS & LINKAGE	 PAGE 110
SDLA Control Levers.....	110
SDLA Linkage	112
Neutral Assist Lever & Neutral Switch.....	114
Parking Brake Handle, Brake Rod, & Shields	116
Parking Brake Linkage & Brake Drum	118
High/Low Range Shift Linkage.....	120
PTO Idler Pulley & Idler Arm	122
PTO Belt Tension Linkage.....	124
Weight Transfer.....	126

TABLE OF CONTENTS

OPTIONS	PAGE 128
3 Point Hitch Frame (Kit #70.4100).....	128
3 Point Hitch Arms (Kit #70.4100).....	130
3 Point Hitch Hydraulics (Kit #70.4100).....	132
3 Point Hitch Hydraulic Diagram (Kit #70.4100).....	134
Rear Hydraulic Valve (Kit # 70.4126).....	136
Rear Hydraulic Valve Diagram (Kit # 70.4126).....	138
Dual Wheels.....	140
70.4111 Suspension Seat Kit.....	142
70.4154 Suspension Seat Kit.....	144
70.0098 Canopy Kit.....	146
70.4113 Work Light Kit.....	148
70.4114 Strobe Light Kit.....	150
70.4155 Strobe Light Kit.....	152
70.4119 Directional / Hazard Light Kit.....	154
70.4156 Directional / Hazard ECE Light Kit.....	156
70.4098 Wheel Extension Kit.....	158
70.4107 Foot Control Kit.....	160
70.4108 Raised Platform Kit.....	162
70.4101 Backup Alarm Kit.....	164
70.4121 Front Hitch Lock Valve Kit.....	166
70.4104 12 Volt Front Plug Kit.....	168
70.4105 12 Volt Rear Plug Kit.....	170
70.4106 PTO Remote Kit.....	172
70.4120 Horn Kit.....	174
70.4135 Slope Indicator Kit.....	176
70.4109 Dual Front Hydraulic Auxiliary Kit.....	178
Dual Front Hydraulic Auxiliary Diagram.....	180
70.4140 Slope Indicator Kit.....	182
39.56114 3N1 Hitch.....	184
39.56116 Rear Counterweight Bar.....	186
70.4137 Mid Weight Bar 4500 Kit.....	188
70.4144 Rear Weight Bar Kit.....	190
70.4133 LED Work Light Kit.....	192
70.2016 Trailer Mover Hitch.....	194

Blank Page

ELECTRICAL

Wiring Diagram Reference Key

Harness Section Identifier

A = 32.0108 - Harness, Rear
B = 32.0109 - Harness, Dash
C = 32.0110 - Harness, Front
D = 32.0107 - Harness, B&S Engine
E = 32.0105 - Harness, Kawasaki Engine
F = 32.0104 - Harness, Kubota Gas
G = 32.0106 - Harness, Kubota Diesel
H =
I =
J = 32.0114 - Harness, Kit - 12v Front
K = 32.0113 - Harness, Kit - 12v Rear
L = 32.0120 - Harness, Kit - 12v Dual Hydraulic
M = 32.0119 - Harness, Kit - Propane
N = 32.0121 - Harness, Kit - PTO Remote
O = 32.0115 - Harness, Kit - Horn
P = 32.0122 - Harness, Kit - Backup Alarm
Q = 32.0118 - Harness, Kit - Directional
R = 32.0117 - Harness, Kit - Strobe Light
S = 32.0116 - Harness, Kit - Work Light
T = 32.0123 - Harness, Kit - Slope Indicator

*@ = 32.0160 - Harness, Kubota WG972
" ^ = 32.0159 - Harness, Kawasaki FD851D Fused

----- = *Black Wire
———— = White Wire
|| ——— = Ground
● = Splice or Connection

* All black wires that are part of the wire harness are part of the ground circuit. However, some components such as lights may be wired where black may be positive.

All other wires colors are as shown

Anything outlined with a blue box is a Standard Feature

Anything outlined with a Green box is a Option

* Actual wires not labeled on tractor harness

Wire Color & Circuit Type

Black = Ground
Dark Blue = Pre-Heat
Lt Blue = Safety Circuit
Brown = Engine Run / Kill
Gray = 12v Aux / Horn power
Green = Start/Speed/Directional
Lt Green = 12 Aux
Orange = Propane / Slope
Pink = Alarm
Purple = PTO
Red = Power
Tan = RPM
White = Power
Yellow = Light/Directional

ELECTRICAL

Wiring Diagram - Rear Harness

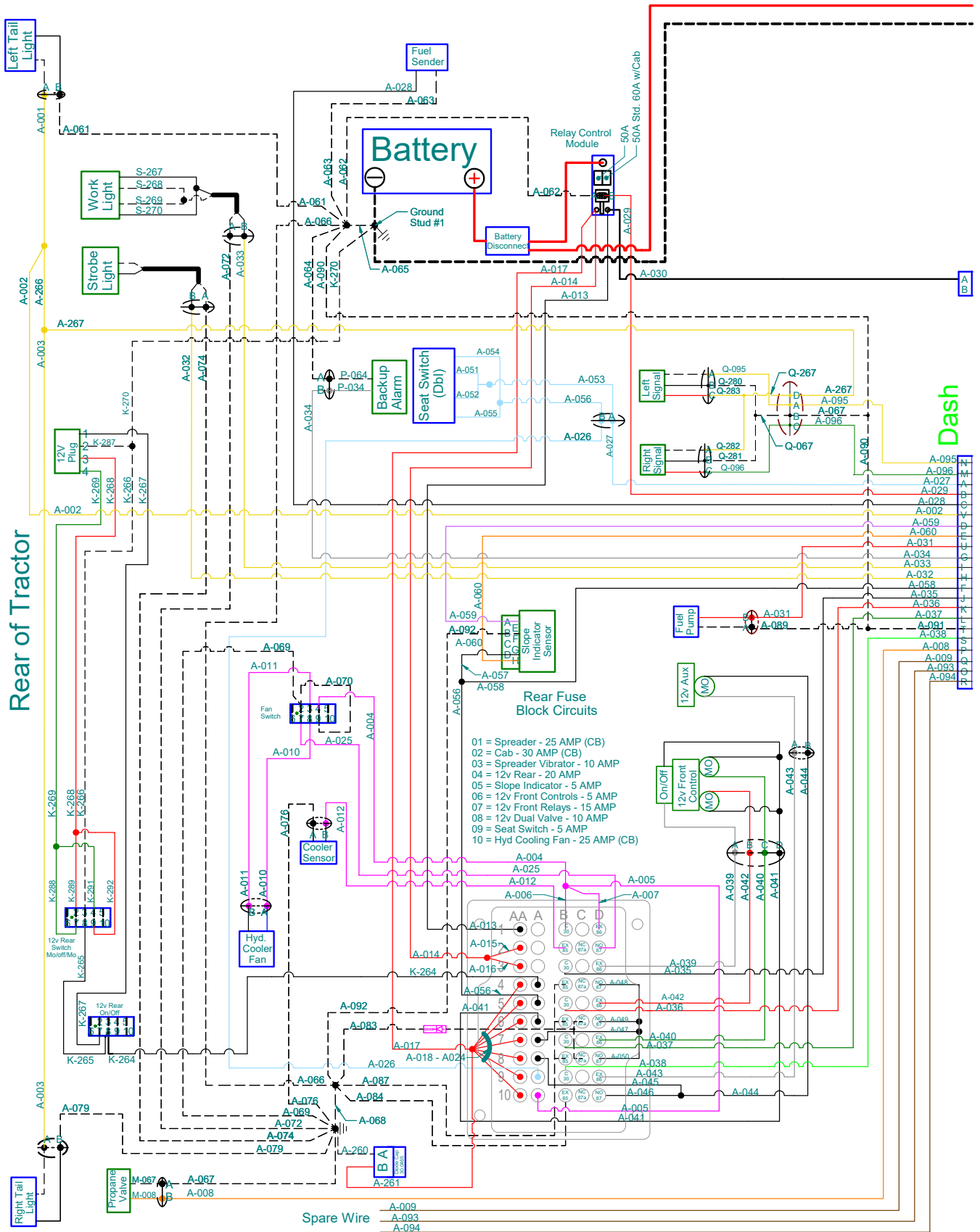

ELECTRICAL

Wiring Diagram - Front Harness

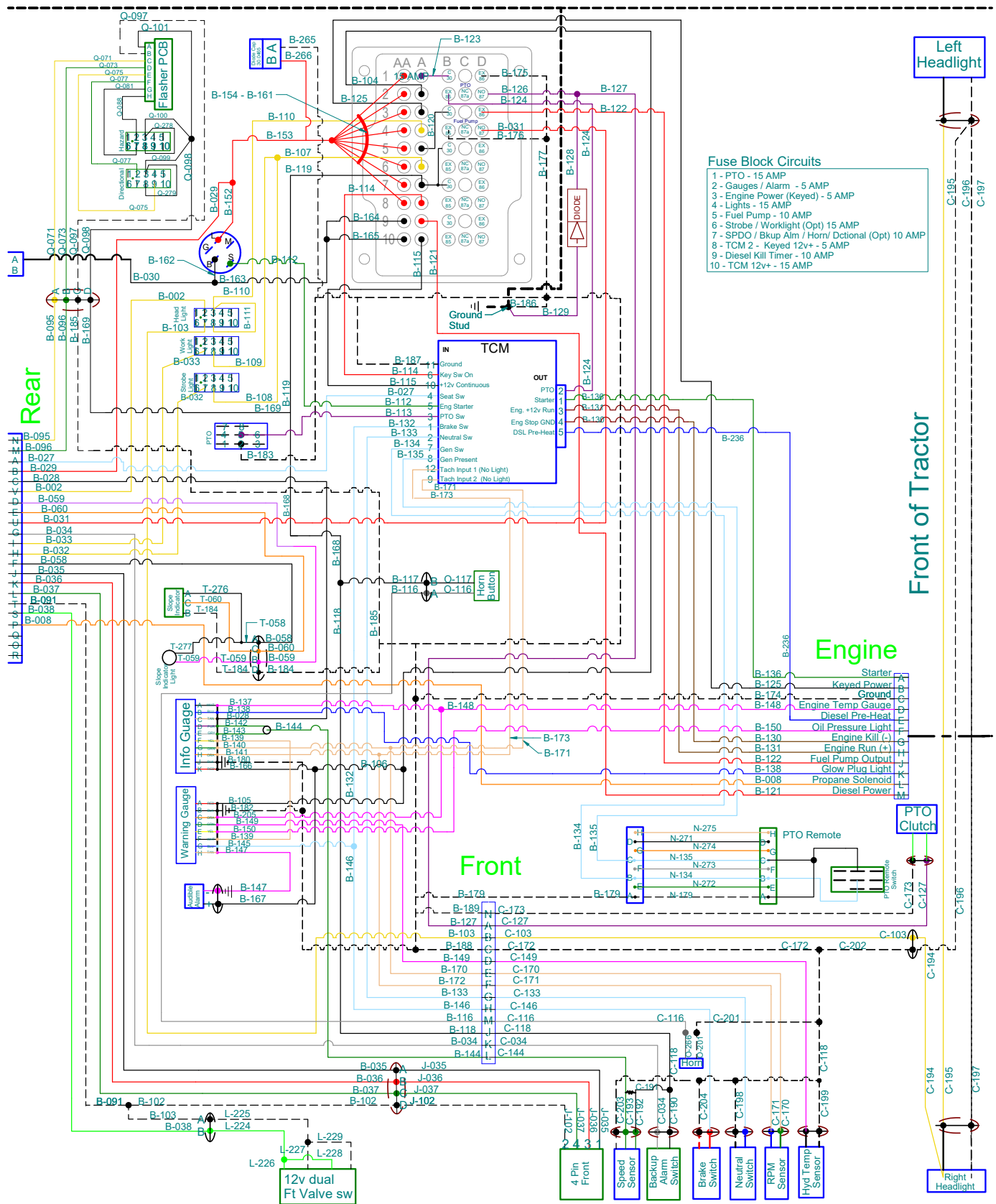

ELECTRICAL

Wiring Diagram - Engine Harness

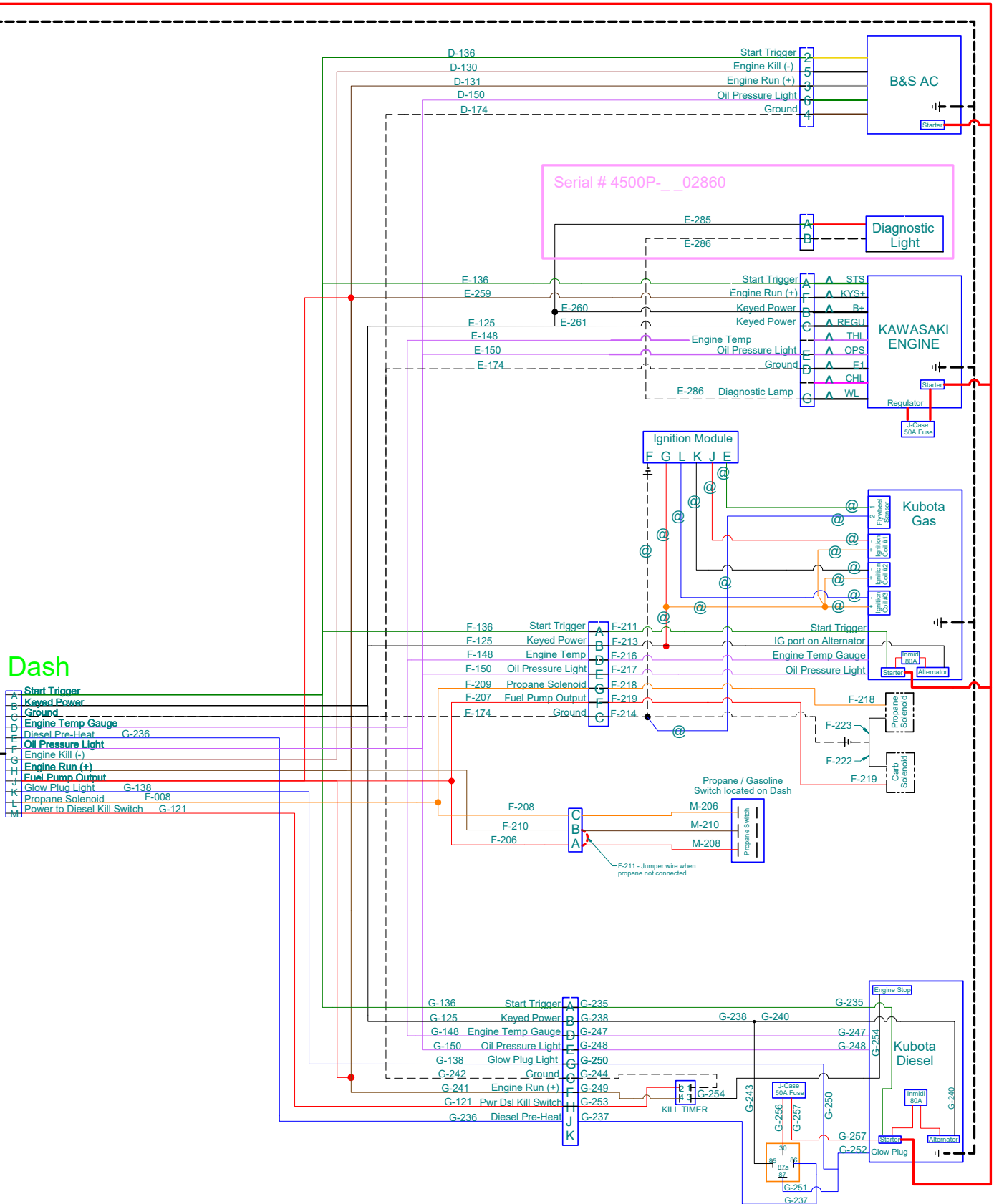

ELECTRICAL

Wiring Diagram - Optional 30.0219 4-Pin Female Socket & 30.0218 4-Pin Male Plug



Attention

This connector (4-pin socket) is designed for use with Ventrac original equipment only. This connector (4-pin socket) is rated for 20 amp maximum current draw. Engine alternator and/or battery capacity determine allowable continuous draw.

30.0219 4-pin female socket is used in the 70.4104 12 Volt Front kit & 70.4105 12 Volt Rear Kit.

Front View of Socket
Without Cover

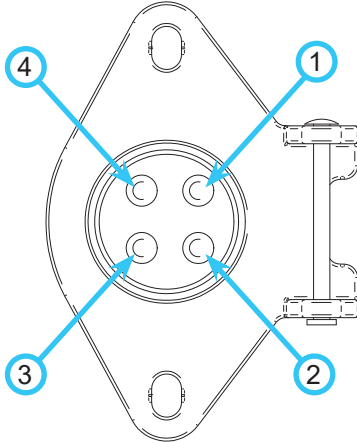

Rear View of Socket

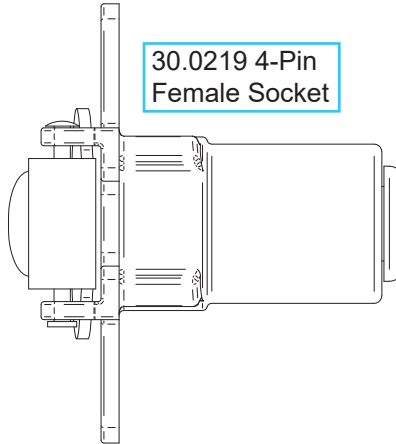
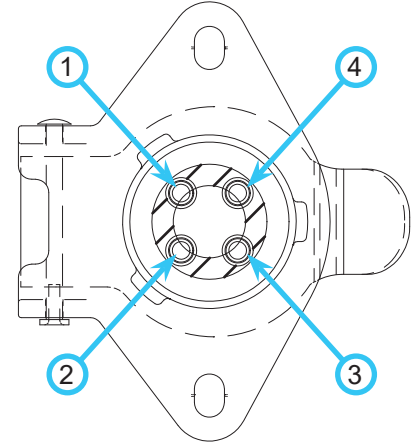

Terminal Position	Wire Color	Function
1	White	Positive (On/Off Switched)
2	Black	Negative (Constant)
3	Red	Positive/Negative (Momentary Switched Reversing)
4	Green or Brown	Positive/Negative (Momentary Switched Reversing)

30.0218 4-pin plug is used on attachments to connect to the 30.0219 socket on the power unit.

Front View of Plug

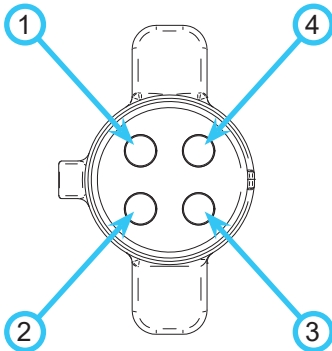

Rear View of Plug

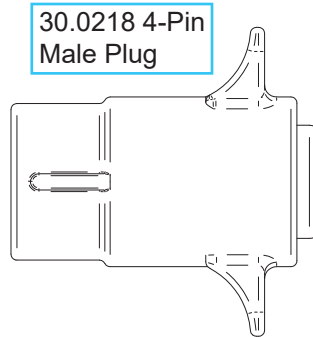
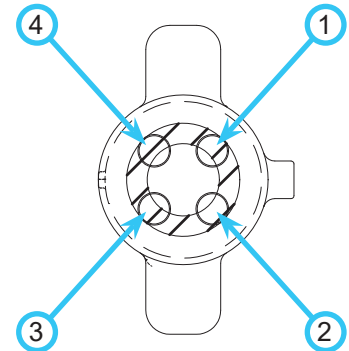

Terminal Position	Wire Color	Function
1	Not Specified*	Positive (On/Off Switched)
2	Not Specified*	Negative (Constant)
3	Not Specified*	Positive/Negative (Momentary Switched Reversing)
4	Not Specified*	Positive/Negative (Momentary Switched Reversing)

* Refer to the part diagram in the attachment's operator's manual for specific wire color and terminal position for each model.

ELECTRICAL

Tractor Control Module

REF.	PART NO.	DESCRIPTION	QTY.
1	35.0128	.MODULE, TRACTOR CONTROL (Serial # 01001-02478)	1
1	35.0146	.MODULE, TRACTOR CONTROL (Serial # 02479-04921)	1
1	35.0134	.MODULE, TRACTOR CONTROL (Serial # 04922)	1
2	64.1690	.BRACKET, TCM	1
3	05.0135	.ISOLATOR, 1/4-20 X 1/2 X 1" F/M	2
4	99.SF04	.NUT, SRF 1/4-20 USS	2
5	95.04	.WASHER, FLAT 1/4 SAE	2
6	90.0408	.BOLT, 1/4-20 USS X 1"	2

ELECTRICAL

ILLUSTRATED DRAWING Battery, Power Cables, & Ground Cables

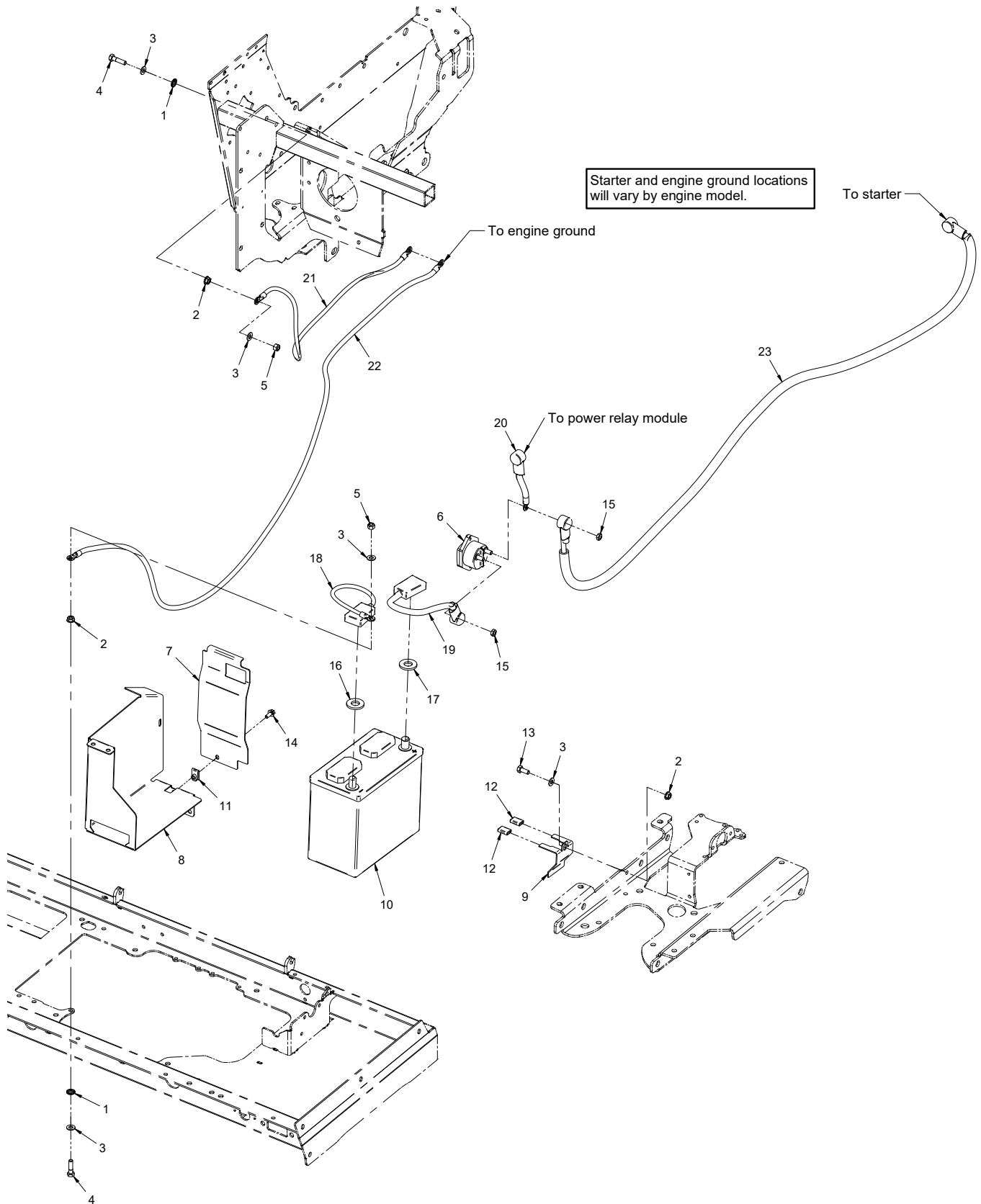

ELECTRICAL

Battery, Power Cables, & Ground Cables

REF.	PART NO.	DESCRIPTION	QTY.
1	99.G0003	.WASHER, STAR-EXTERNAL 5/16	2
2	99.SF05	.NUT, SRF 5/16-18 USS	3
3	95.05	.WASHER, FLAT 5/16 SAE	5
4	90.0510	.BOLT, 5/16-18 USS X 1-1/4"	2
5	99.A05N	.LOCKNUT, NYLON 5/16-18 USS	2
6	30.0338	.BREAKER, CIRCUIT 150 AMP	1
7	60.1117	.PANEL, FOOT PLATFORM LEFT	1
8	60.1116	.PANEL, BATTERY COMPARTMENT	1
9	64.1593	.RETAINER, BATTERY HOLD DOWN	1
10	33.0060	.BATTERY, GROUP 51-60	1
11	99.E0046	.NUT, "U" 1/4-20 EXTRUDED	1
12	06.0044	.CAP, PLASTIC 1/8 X 1/2 X 7/8	2
13	90.0506	.BOLT, 5/16-18 USS X 3/4"	1
14	99.SF0405-1	.BOLT, SMF 1/4-20 X 5/8	1
15	99.E0060	.NUT, JAM 5/16-18 USS	2
16	05.0122	.WASHER, ANTI CORROSION BLACK	1
17	05.0121	.WASHER, ANTI CORROSION RED	1
18	32.0101	.CABLE, ASM NEG BATTERY 4GA	1
19	32.0100	.CABLE, ASM POS BATTERY 4GA	1
20	32.0111	.CABLE, ASM POS 6 GA	1
21	32.0112	.CABLE, ASM NEG 4GA	1
22	32.0103	.CABLE, ASM NEG 4GA	1
23	32.0102	.CABLE, ASM POS 4GA	1

ELECTRICAL

ILLUSTRATED DRAWING Front Fuse Panel

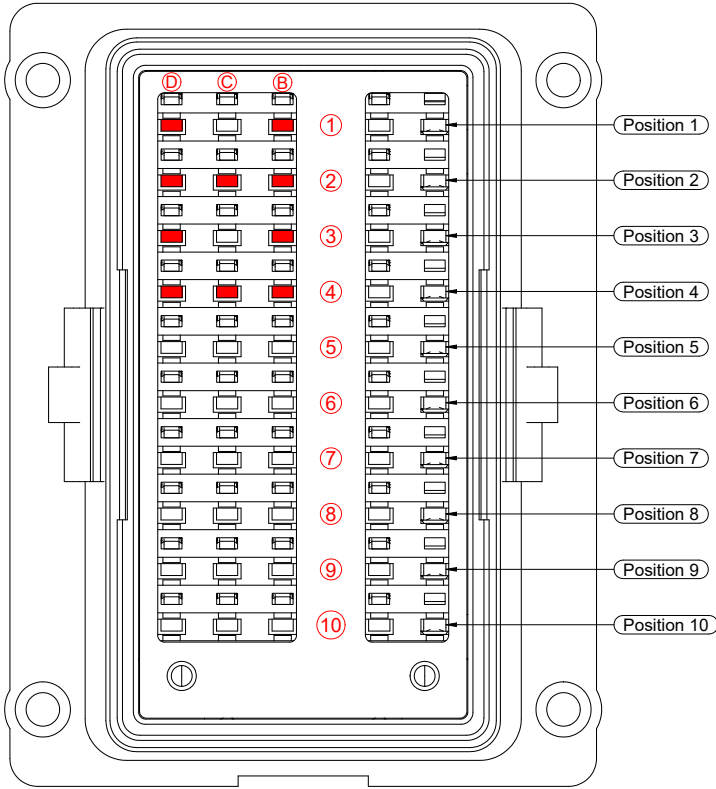

Ref. # / Position	Circuit
1	PTO
2	Gauges
3	Engine
4	Lights
5	Fuel Pump
6*	Work / Strobe Light
7*	Backup Alarm / Horn / Direction Lights
8	TCM 1
9^	Diesel Stop
10	TCM 2

*Optional Accessory
^ Diesel Only

Reference 15 relays are installed in Position 1 - 2 and Position 3 - 4 as referenced by shaded ports. The relays must be oriented with the single center pin down.

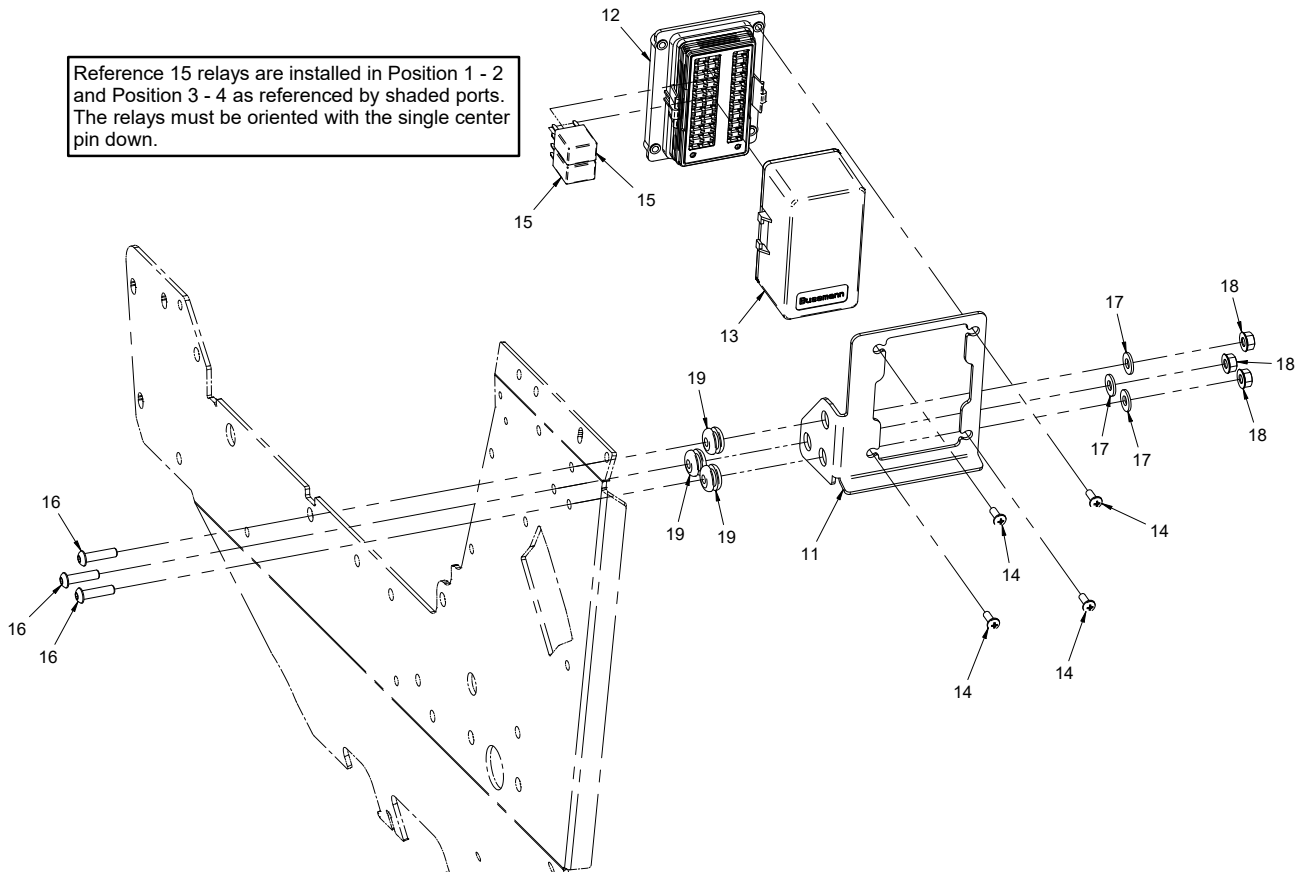

ELECTRICAL

Front Fuse Panel

REF.	PART NO.	DESCRIPTION	QTY.
1	30.0334	.FUSE, 15 AMP MINI BLUE	1
2	30.0332	.FUSE, 5 AMP MINI TAN	1
3	30.0332	.FUSE, 5 AMP MINI TAN	1
4	30.0334	.FUSE, 15 AMP MINI BLUE	1
5	30.0333	.FUSE, 10 AMP MINI RED	1
6	30.0334	.FUSE, 15 AMP MINI BLUE	1
7	30.0333	.FUSE, 10 AMP MINI RED	1
8	30.0332	.FUSE, 5 AMP MINI TAN	1
9	30.0333	.FUSE, 10 AMP MINI RED	1
10	30.0334	.FUSE, 15 AMP MINI BLUE	1
11	64.1648	.BRACKET, FUSE PANEL MOUNT	1
12	30.0356	.FUSE PANEL, MINI NON-BUSSED	1
13	30.0331	.COVER, FUSE PANEL 30.0329	1
14	99.K0062	.MACHINE SCREW, #10-32 X 1/2	4
15	35.0117	.RELAY, 12V 35/20 AMP 280 MICRO	2
16	99.0408	.BOLT, 1/4-20 X 1 BSCS	3
17	95.04	.WASHER, FLAT 1/4 SAE	3
18	99.E0101	.NUT, LOCKING FLANGE 1/4-20	3
19	05.0146	.GROMMET, 1/4ID, 3/4OD, 7/16THK	3

ELECTRICAL

ILLUSTRATED DRAWING Rear Fuse Panel

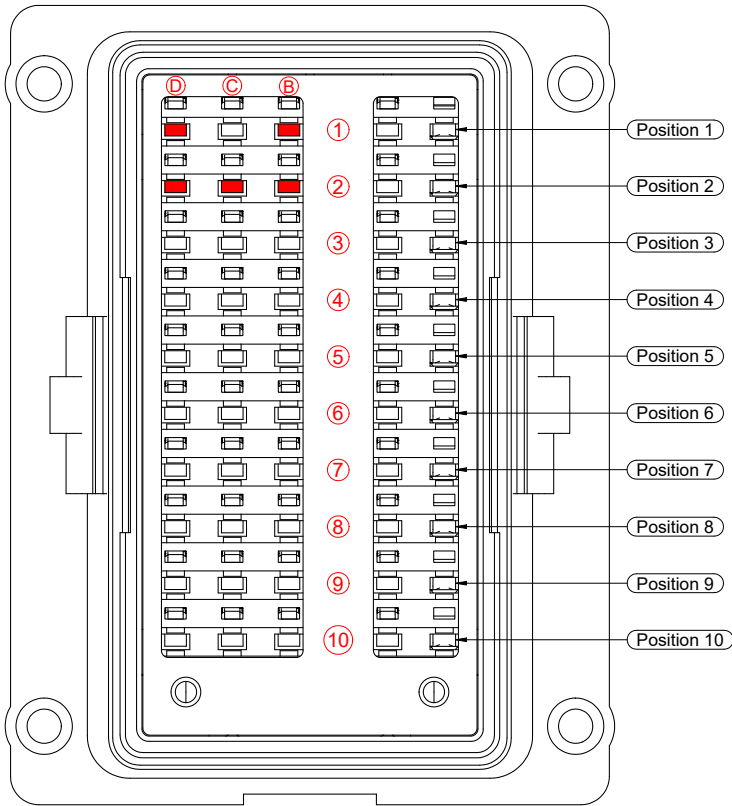

Ref. # / Position	Circuit
1*	Spreader
2*	Weather Cab
3*	Spreader Vibrator
4*	12 Volt Rear
5*	Slope Indicator
6*	12 Volt Front 1
7*	12 Volt Front 2
8*	Hydraulic Auxiliary
9	Seat Switch
10	Hydraulic Oil Cooler Fan
*Optional Accessory	

Reference 14 relay is installed in Position 1 - 2 as referenced by shaded ports. The relay must be oriented with the single center pin down.

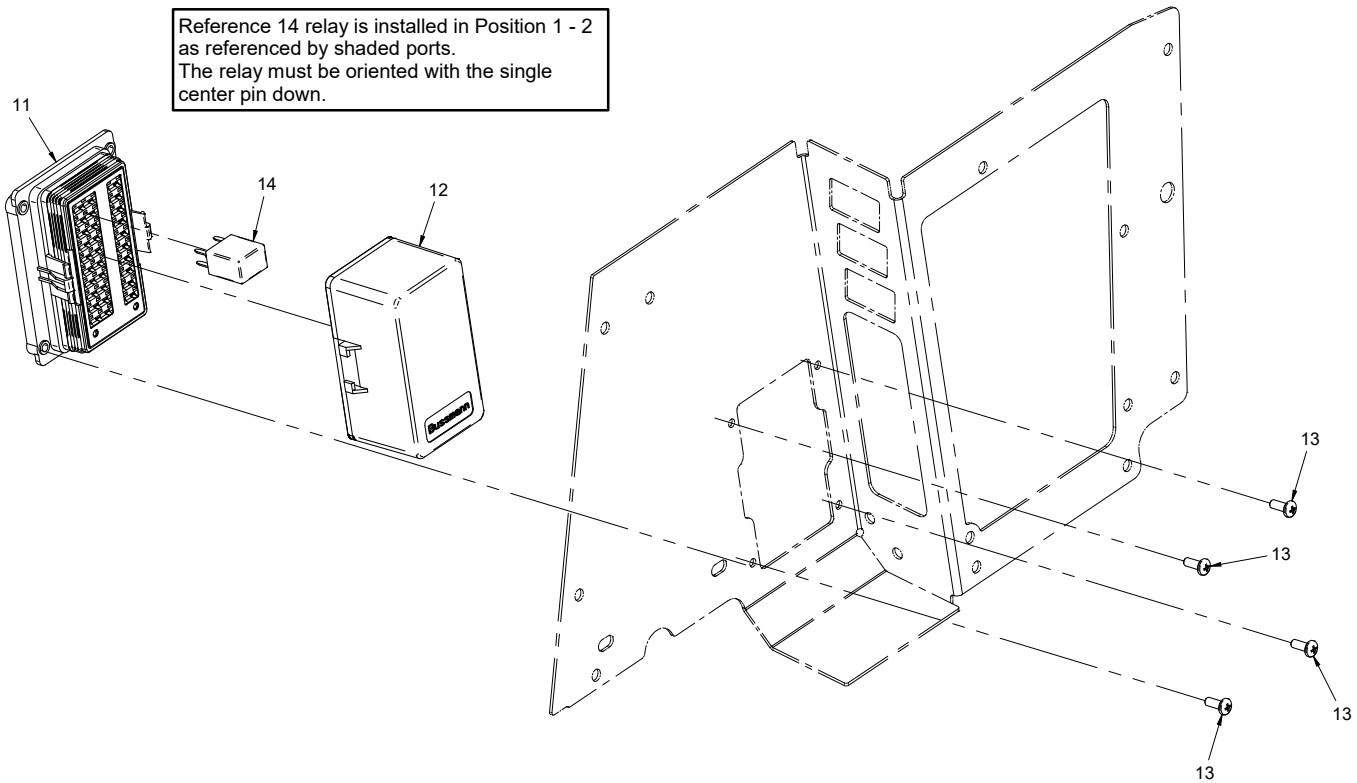

ELECTRICAL

Rear Fuse Panel

REF.	PART NO.	DESCRIPTION	QTY.
1	30.0429	.BREAKER, CIRCUIT 25 AMP MINI	1
2	30.0445	.BREAKER, CIRCUIT 30 AMP MINI	1
3	30.0333	.FUSE, 10 AMP MINI RED	1
4	30.0335	.FUSE, 20 AMP MINI YELLOW	1
5	30.0332	.FUSE, 5 AMP MINI TAN	1
6	30.0332	.FUSE, 5 AMP MINI TAN	1
7	30.0334	.FUSE, 15 AMP MINI BLUE	1
8	30.0333	.FUSE, 10 AMP MINI RED	1
9	30.0332	.FUSE, 5 AMP MINI TAN	1
10	30.0429	.BREAKER, CIRCUIT 25 AMP MINI	1
11	30.0356	.FUSE PANEL, MINI NON-BUSSED	1
12	30.0331	.COVER, FUSE PANEL 30.0329	1
13	99.K0062	.MACHINE SCREW, #10-32 X 1/2	4
14	35.0117	.RELAY, 12V 35/20 AMP 280 MICRO	1

ELECTRICAL

ILLUSTRATED DRAWING Power Relay Module

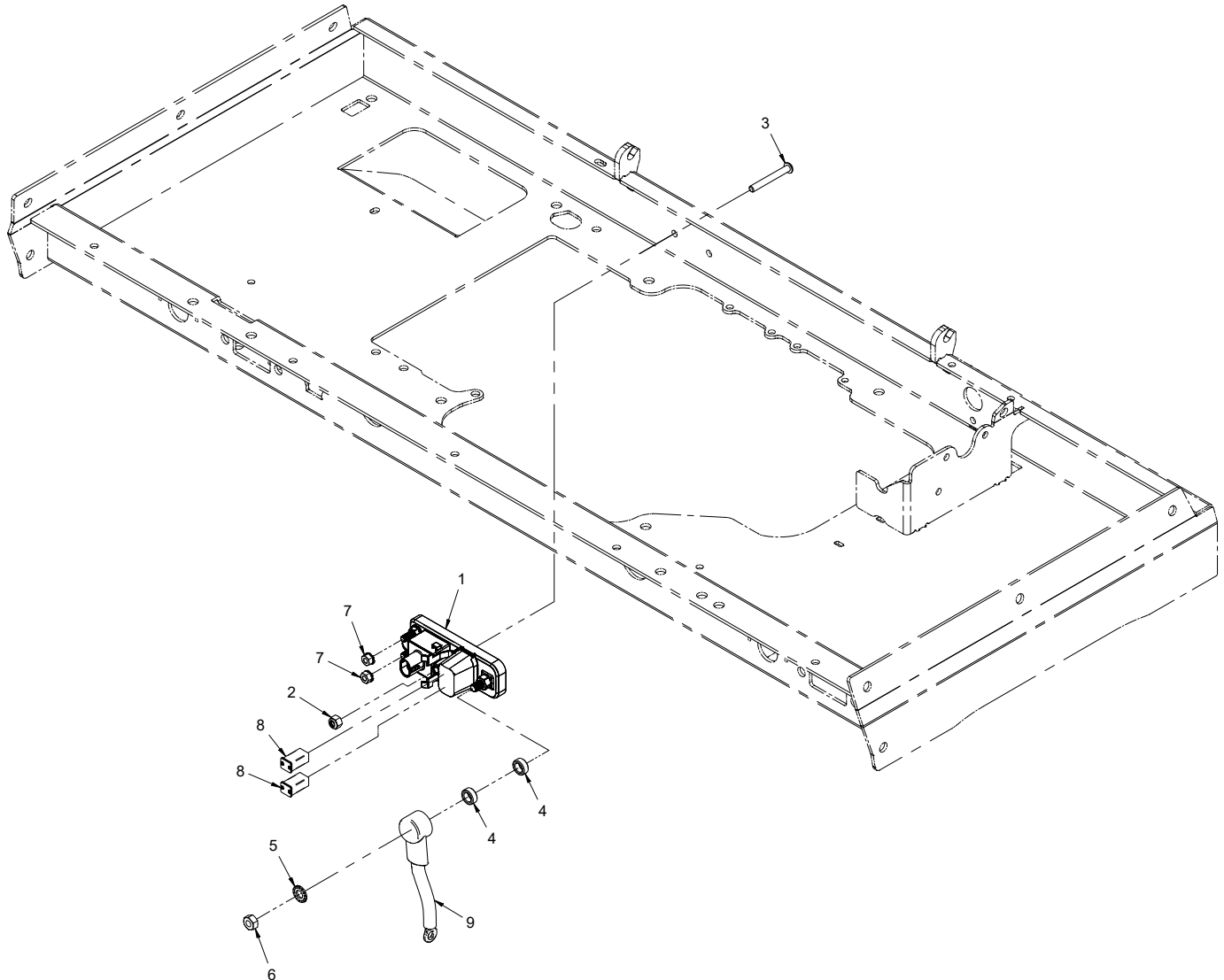

ELECTRICAL

Power Relay Module

REF.	PART NO.	DESCRIPTION	QTY.
1	30.0339	.MODULE, POWER RELAY	1
2	99.A04N	.LOCKNUT, NYLON 1/4-20	1
3	99.0416	.BOLT, 1/4-20 X 2 BSCS	1
4	64.0602	.BUSHING, 3/8 X 5/8 X .265	2
5	99.G0003	.WASHER, STAR-EXTERNAL 5/16	1
6	99.M0008	.NUT, M8 X 1.25MM ZP	1
7	99.M0029	.NUT, M6 X 1.0 W/LOCK WASHER	2
8	30.0374	.FUSE, 50A J-CASE ORANGE	2
9	32.0111	.CABLE, ASM POS 6 GA.	1

ELECTRICAL

ILLUSTRATED DRAWING RPM Sensor

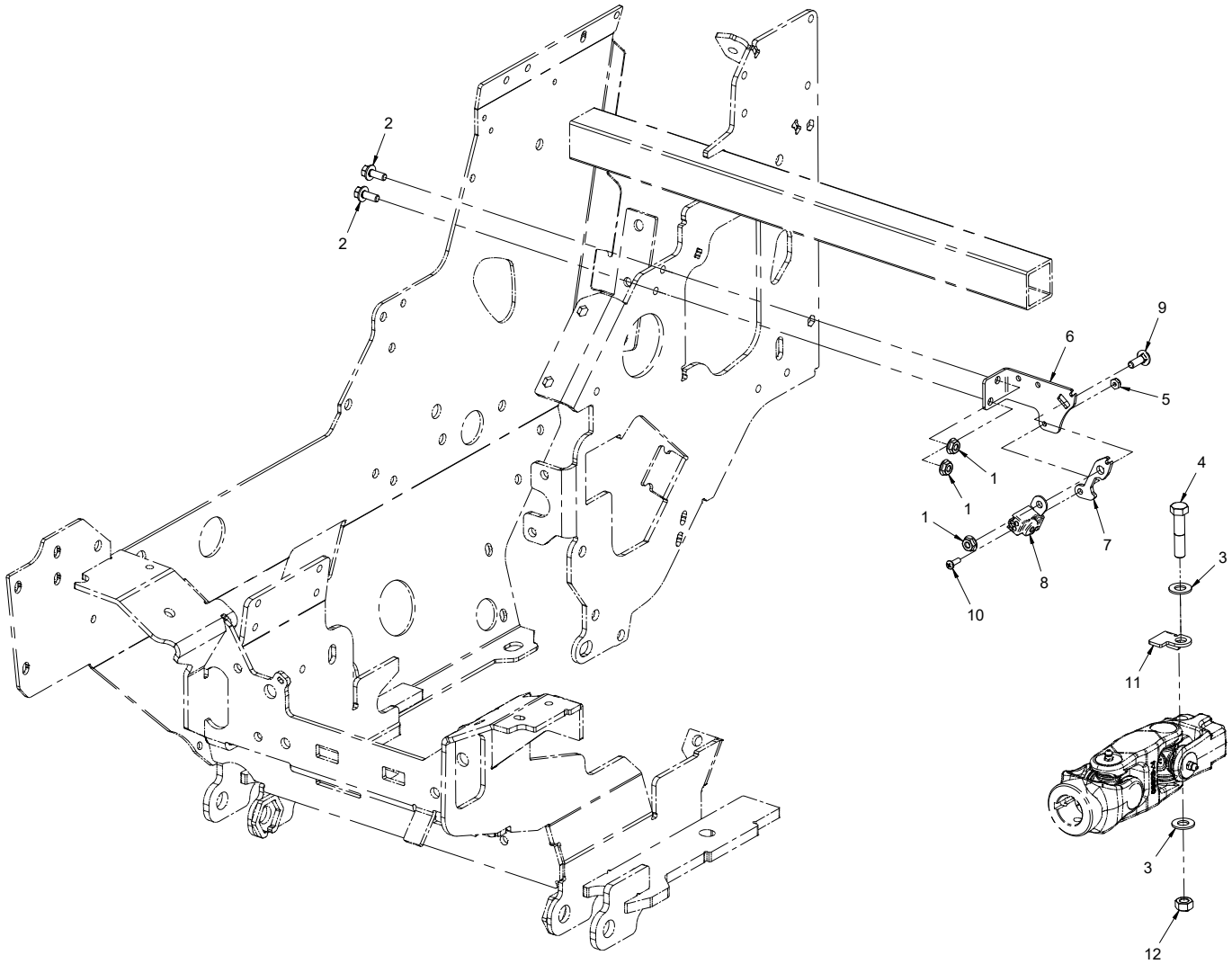

ELECTRICAL

RPM Sensor

REF.	PART NO.	DESCRIPTION	QTY.
1	99.SF04	.NUT, SRF 1/4-20 USS	3
2	99.SF0405-1	.BOLT, SMF 1/4-20 X 5/8	2
3	95.06	.WASHER, FLAT 3/8 SAE	2
4	90.0614	.BOLT, 3/8-16 USS X 1-3/4	1
5	99.E0062	.NUT, SRF #8-32	1
6	64.1653	.BRACKET, RPM SENSOR MOUNT	1
7	64.1655	.PLATE, TACH RPM SENSOR SPACER	1
8	13.0162	.TRIGGER, IGNITION	1
9	97.0406	.BOLT, CARRIAGE 1/4 X 3/4	1
10	99.K0041	.MACHINE SCREW, #8-32 X 1/2	1
11	64.1654	.PLATE, DRIVESHAFT TACH TRIGGER	1
12	99.A06	.LOCKNUT, STOVER 3/8-16 USS	1

ELECTRICAL

ILLUSTRATED DRAWING Speedometer Sensor

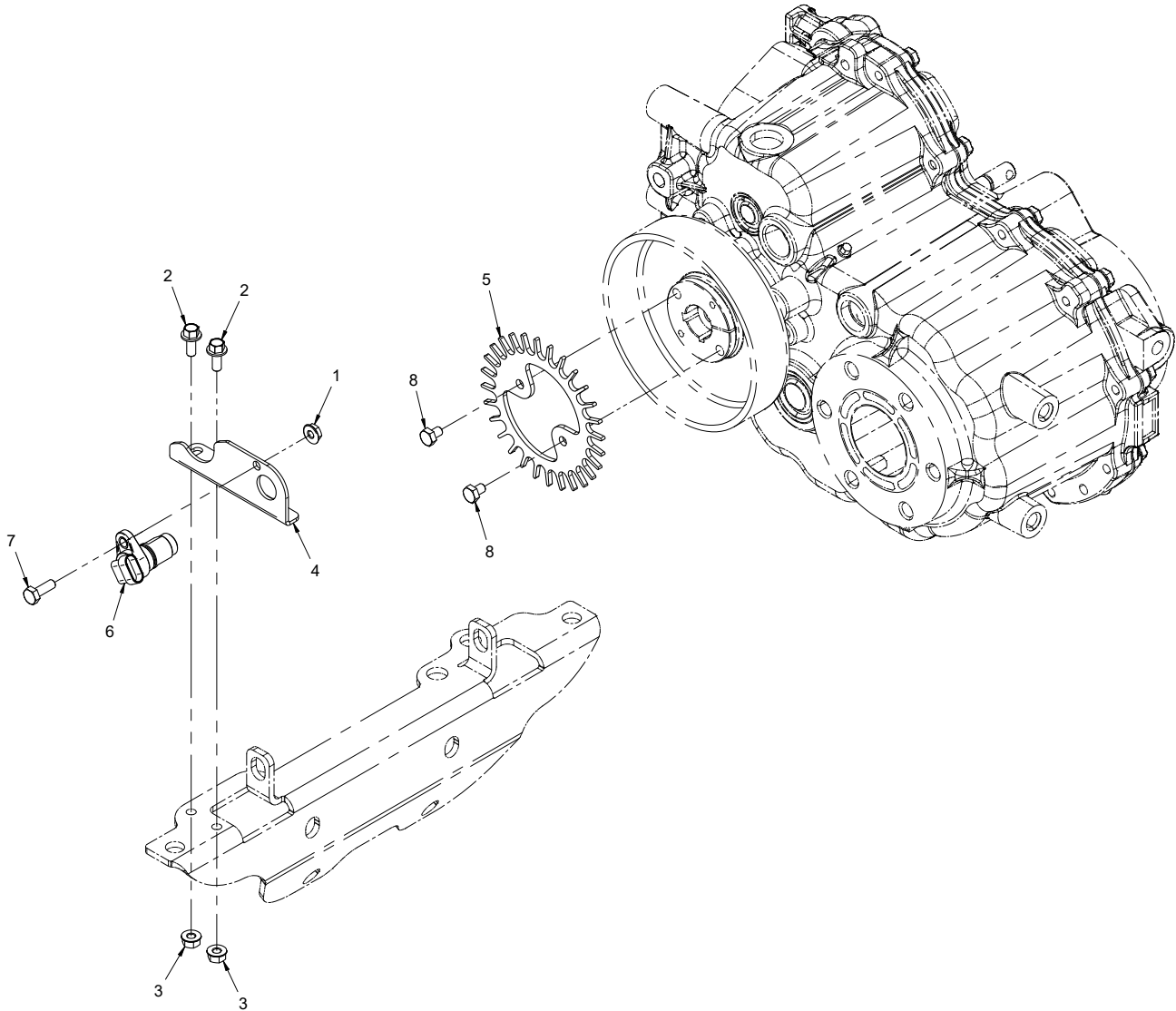

ELECTRICAL

Speedometer Sensor

REF.	PART NO.	DESCRIPTION	QTY.
1	99.SF04	.NUT, SRF 1/4-20 USS.	1
2	99.SF0405-1	.BOLT, SMF 1/4-20 X 5/8	2
3	99.E0101	.NUT, LOCKING FLANGE 1/4-20	2
4	64.1604	.BRACKET, SPEED SENSOR MOUNT	1
5	64.1606	.PLATE, SPEED INDICATOR	1
6	35.0121	.SENSOR, GEAR TOOTH SPEED	1
7	90.0406	.BOLT, 1/4-20 USS X 3/4"	1
8	90.0403	.BOLT, 1/4-20 USS X 3/8	2

HYDRAULICS, AXLES, & WHEELS

ILLUSTRATED DRAWING Hydraulic Diagram

ALL VIEWS ARE FROM REAR OF TRACTOR, OR AS NOTED

OPEN LOOP IMPLEMENT CIRCUIT

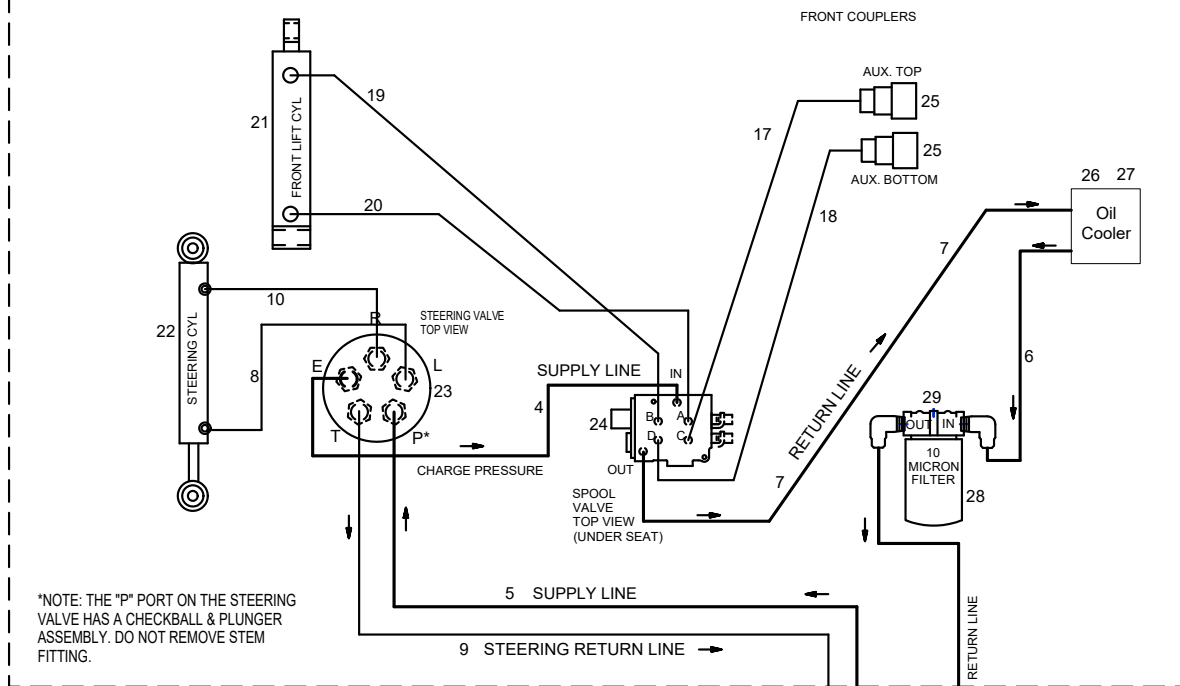

CLOSED LOOP DRIVE CIRCUIT^A HIGH PRESSURE

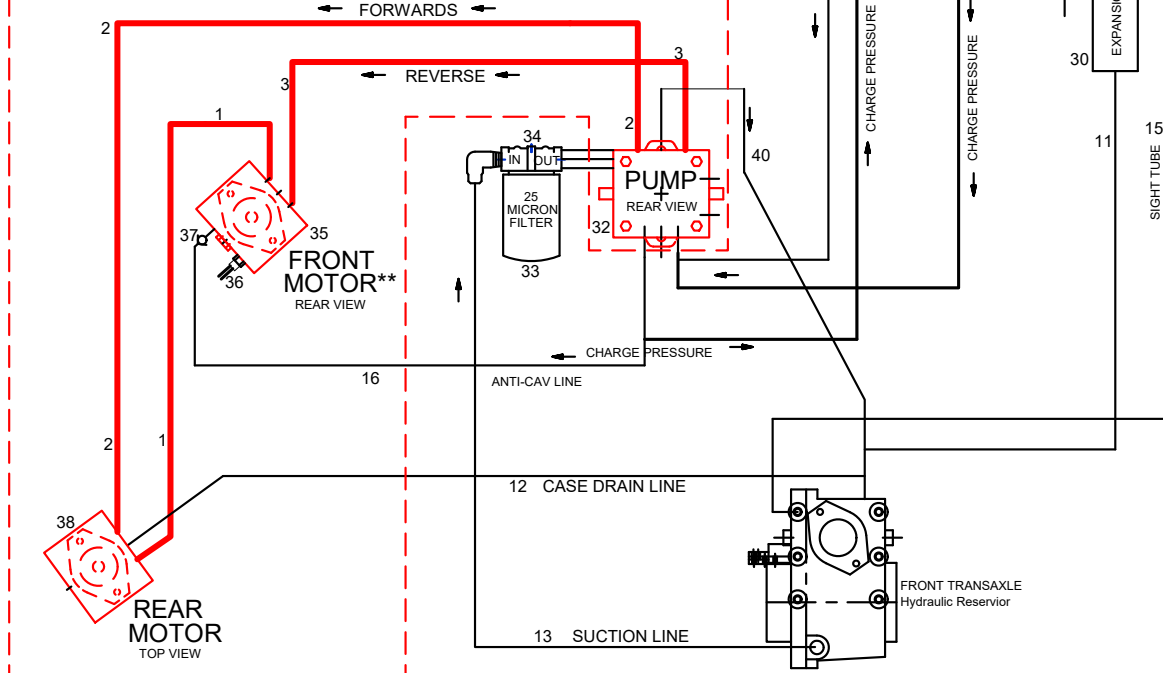

^AIF ANY PART OF THE CLOSED LOOP HYDROSTATIC DRIVE CIRCUIT (PUMP, FRONT DRIVE MOTOR, REAR DRIVE MOTOR, OR ANY OF THE THREE 1/2" HYDRAULIC LINES CONNECTING THEM TOGETHER) IS SERVICED OR REPLACED, THE VENTRAC CLOSED LOOP DRIVE CIRCUIT FILTRATION PROCEDURE MUST BE PERFORMED. THIS PROCEDURE REQUIRES A SPECIAL VENTRAC REMOTE FILTERING TOOL (KIT # 70.0122) AND MUST BE PERFORMED BY A VENTRAC AUTHORIZED TECHNICIAN. FAILURE TO PERFORM THIS FILTERING PROCEDURE FOLLOWING A REPAIR CAN RESULT IN COMPONENT AND/OR COMPLETE SYSTEM FAILURE AND MAY VOID WARRANTY.

**NOTE: THE FRONT TRANSAXLE IS PART OF THE HYDRAULIC SYSTEM, SO THE FRONT MOTOR MUST HAVE THE SEAL REMOVED. THE REAR TRANSAXLE IS SEPARATE FROM THE HYDRAULIC SYSTEM, SO THE SHAFT SEAL IN THE REAR MOTOR MUST NOT BE REMOVED.

HYDRAULICS, AXLES, & WHEELS

Hydraulic Diagram

REF.	PART NO.	DESCRIPTION	QTY.
1	20.0295	.HOSE, 1/2X55.00 SS BRAID PTFE	1
2	20.0296	.HOSE, 1/2X74.50 SS BRAID PTFE	1
3	20.0297	.HOSE, 1/2X18.38 SS BRAID PTFE	1
4	20.0298	.HOSE, 3/8X56.00 SAE 100R17 AR	1
5	20.0155	.HOSE, 3/8X19.00 SAE 100R17AR	1
6	20.0300	.HOSE, 3/8X69.00 SAE 100R17 AR	1
7	20.0299	.HOSE, 3/8X32.00 SAE 100R17 AR	1
8	20.0122	.HOSE, 1/4X43.00 SAE 100R17AR	1
9	20.0123	.HOSE, 1/4X19.50 SAE 100R17AR	1
10	20.0136	.HOSE, 1/4X36.00 SAE 100R17AR	1
11	22.0052	.HOSE, 1/2X22.00 PLK 250PSI CPE	1
12	22.0058	.HOSE, 3/8X54.00 PLK 250PSI CPE	1
13	22.0050	.HOSE, 3/4X22.00 PLK 250PSI CPE	1
14	27.F04-30IN	.HOSE, FUEL LINE 1/4 X 30"	1
15	27.T06-3-36IN.	.TUBE, SILICON 3/8" ID X 36"	1
16	20.0304	.HOSE, 1/4X20.50 SAE 100R17 AR	1
17	20.0303	.HOSE, 1/4X58.00 SAE 100R17 AR	1
18	20.0303	.HOSE, 1/4X58.00 SAE 100R17 AR	1
19	20.0303	.HOSE, 1/4X58.00 SAE 100R17 AR	1
20	20.0302	.HOSE, 1/4X48.00 SAE 100R17 AR	1
21	23.0156	.CYLINDER, 2-1/4" X 7" LIFT	1
22	23.0145	.CYLINDER, 1-3/4" X 8 STEERING	1
23	23.0113	.VALVE, STEERING-DANFOSS 100CC.	1
24	23.0111-1	.VALVE, HY 2 SPL W/LH FLT,RH SP	1
25	23.0106	.COUPLER, QUICK FEMALE 1/4	2
26	21.0121	.COOLER, HYDRAULIC	1
27	13.0239	.SWITCH, TEMPERATURE	1
28	21.0124	.FILTER, HYD. 10 MICRON CEL	1
29	21.0123	.FILTER, HEAD 06 ORB	1
30	47.0315	.TANK, OIL	1
31	47.0319	.CAP, COOLANT RECOVERY TANK	1
32	21.0080	.PUMP, HYDRAULIC	1
33	21.0122	.FILTER, HYD. 25 MICRON SYN	1
34	21.0119	.FILTER, HEAD -10 ORB PORTS	1
35	21.0081**	.MOTOR, HYD. SUNDSTRAND	1
36	13.0254	.SWITCH, TEMP -08 SAE ORB	1
37	23.0159	.VALVE, CHECK VONBERG	1
38	21.0081**	.MOTOR, HYD. SUNDSTRAND	1
39	20.0301	.HOSE, 3/8X20.00 SAE 100R17 AR	1
40	22.0059	.HOSE, 1/2X17.00 PLK 250PSI CPE	1

**When replacing the front motor, the shaft seal must be removed.
 When replacing the rear motor, the shaft seal MUST NOT be removed.

HYDRAULICS, AXLES, & WHEELS

O-Ring Chart

Straight Thread O-Ring Boss - O-Ring Replacement Part Numbers						
SAE Fitting Size	Thread Size	VPI Part #	ID	OD	Width	AS568A Dash #
-04	7/16-20	26.0035	0.351"	0.495"	0.072"	904
-06	9/16-18	26.0036	0.468"	0.624"	0.078"	906
-08	3/4-16	26.0037	0.644"	0.818"	0.087"	908
-10	7/8-14	26.0038	0.755"	0.949"	0.097"	910
-12	1-1/16-12	26.0039	0.924"	1.156"	0.116"	912
-16	1-5/16-12	26.0043	1.171"	1.403"	0.116"	916

O-Ring Face Seal Hose - O-Ring Replacement Part Numbers						
SAE Fitting Size	Thread Size	VPI Part #	ID	OD	Width	AS568A Dash #
-04	9/16-18	26.0044	0.301"	0.441"	0.070"	011
-06	11/16-16	26.0025	0.364"	0.504"	0.070"	012
-08	13/16-16	26.0009	0.489"	0.629"	0.070"	014
-10	1-14	26.0023	0.614"	0.754"	0.070"	016
-12	1-3/16-12	26.0045	0.739"	0.879"	0.070"	018
-16	1-7/16-12	26.0046	0.926"	1.066"	0.070"	021

Fitting Chart

25.6400-(xx)-(xx) Fitting

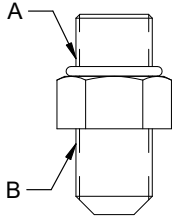

Fitting End A		O-Ring		Fitting End B		O-Ring	
SAE Fitting Size	Thread Size	AS568A Dash #	VPI Part #	SAE Fitting Size	Thread Size	AS568A Dash #	VPI Part #
-04	7/16-20	904	26.0035	-04	7/16-20	-	-
-06	9/16-18	906	26.0036	-06	9/16-18	-	-
-08	3/4-16	908	26.0037	-08	3/4-16	-	-
-10	7/8-14	910	26.0038	-10	7/8-14	-	-
-12	1-1/16-12	912	26.0039	-12	1-1/16-12	-	-
-16	1-5/16-12	916	26.0043	-16	1-5/16-12	-	-

25.6407-(xx)-(xx) Fitting

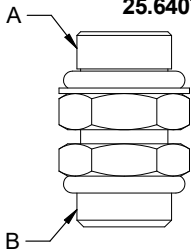

Fitting End A		O-Ring		Fitting End B		O-Ring	
SAE Fitting Size	Thread Size	AS568A Dash #	VPI Part #	SAE Fitting Size	Thread Size	AS568A Dash #	VPI Part #
-04	7/16-20	904	26.0035	-04	7/16-20	904	26.0035
-06	9/16-18	906	26.0036	-06	9/16-18	906	26.0036
-08	3/4-16	908	26.0037	-08	3/4-16	908	26.0037
-10	7/8-14	910	26.0038	-10	7/8-14	910	26.0038
-12	1-1/16-12	912	26.0039	-12	1-1/16-12	912	26.0039
-16	1-5/16-12	916	26.0043	-16	1-5/16-12	916	26.0043

25.6408-(xx) Plug

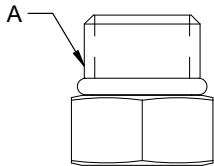

Fitting End A		O-Ring	
SAE Fitting Size	Thread Size	AS568A Dash #	VPI Part #
-04	7/16-20	904	26.0035
-06	9/16-18	906	26.0036
-08	3/4-16	908	26.0037
-10	7/8-14	910	26.0038
-12	1-1/16-12	912	26.0039
-16	1-5/16-12	916	26.0043

HYDRAULICS, AXLES, & WHEELS

Fitting Chart

25.6801-(xx)-(xx) Fitting

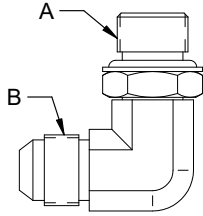

Fitting End A		O-Ring		Fitting End B		O-Ring	
SAE Fitting Size	Thread Size	AS568A Dash #	VPI Part #	SAE Fitting Size	Thread Size	AS586A Dash #	VPI Part #
-04	7/16-20	904	26.0035	-04	7/16-20	-	-
-06	9/16-18	906	26.0036	-06	9/16-18	-	-
-08	3/4-16	908	26.0037	-08	3/4-16	-	-
-10	7/8-14	910	26.0038	-10	7/8-14	-	-
-12	1-1/16-12	912	26.0039	-12	1-1/16-12	-	-
-16	1-5/16-12	916	26.0043	-16	1-5/16-12	-	-

25.6802-(xx)-(xx) Fitting

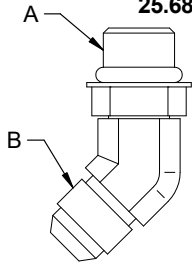

Fitting End A		O-Ring		Fitting End B		O-Ring	
SAE Fitting Size	Thread Size	AS568A Dash #	VPI Part #	SAE Fitting Size	Thread Size	AS586A Dash #	VPI Part #
-04	7/16-20	904	26.0035	-04	7/16-20	-	-
-06	9/16-18	906	26.0036	-06	9/16-18	-	-
-08	3/4-16	908	26.0037	-08	3/4-16	-	-
-10	7/8-14	910	26.0038	-10	7/8-14	-	-
-12	1-1/16-12	912	26.0039	-12	1-1/16-12	-	-
-16	1-5/16-12	916	26.0043	-16	1-5/16-12	-	-

25.6804-(x)-(x)-(x) Fitting

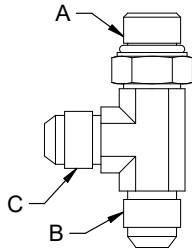

Fitting End A		O-Ring		Fitting End B & C		O-Ring	
SAE Fitting Size	Thread Size	AS568A Dash #	VPI Part #	SAE Fitting Size	Thread Size	AS586A Dash #	VPI Part #
-04	7/16-20	904	26.0035	-04	7/16-20	-	-
-06	9/16-18	906	26.0036	-06	9/16-18	-	-
-08	3/4-16	908	26.0037	-08	3/4-16	-	-
-10	7/8-14	910	26.0038	-10	7/8-14	-	-
-12	1-1/16-12	912	26.0039	-12	1-1/16-12	-	-
-16	1-5/16-12	916	26.0043	-16	1-5/16-12	-	-

25.FF6400-(xx)-(xx) Fitting

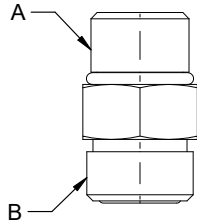

Fitting End A		O-Ring		Fitting End B		O-Ring	
SAE Fitting Size	Thread Size	AS568A Dash #	VPI Part #	SAE Fitting Size	Thread Size	AS586A Dash #	VPI Part #
-04	7/16-20	904	26.0035	-04	9/16-18	011	26.0044
-06	9/16-18	906	26.0036	-06	11/16-16	012	26.0025
-08	3/4-16	908	26.0037	-08	13/16-16	014	26.0009
-10	7/8-14	910	26.0038	-10	1-14	016	26.0023
-12	1-1/16-12	912	26.0039	-12	1-3/16-12	018	26.0045
-16	1-5/16-12	916	26.0043	-16	1-7/16-12	021	26.0046

25.FF6500-(xx)-(xx) Fitting

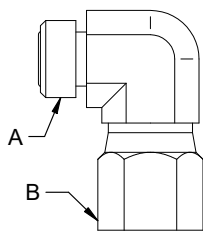

Fitting End A		O-Ring		Fitting End B		O-Ring	
SAE Fitting Size	Thread Size	AS568A Dash #	VPI Part #	SAE Fitting Size	Thread Size	AS586A Dash #	VPI Part #
-04	9/16-18	011	26.0044	-04	9/16-18	-	-
-06	11/16-16	012	26.0025	-06	11/16-16	-	-
-08	13/16-16	014	26.0009	-08	13/16-16	-	-
-10	1-14	016	26.0023	-10	1-14	-	-
-12	1-3/16-12	018	26.0045	-12	1-3/16-12	-	-
-16	1-7/16-12	021	26.0046	-16	1-7/16-12	-	-

HYDRAULICS, AXLES, & WHEELS

Fitting Chart

25.FF6502-(xx)-(xx) Fitting

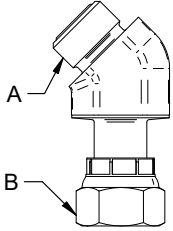

Fitting End A		O-Ring		Fitting End B		O-Ring	
SAE Fitting Size	Thread Size	AS568A Dash #	VPI Part #	SAE Fitting Size	Thread Size	AS568A Dash #	VPI Part #
-04	9/16-18	011	26.0044	-04	9/16-18	-	-
-06	11/16-16	012	26.0025	-06	11/16-16	-	-
-08	13/16-16	014	26.0009	-08	13/16-16	-	-
-10	1-14	016	26.0023	-10	1-14	-	-
-12	1-3/16-12	018	26.0045	-12	1-3/16-12	-	-
-16	1-7/16-12	021	26.0046	-16	1-7/16-12	-	-

25.FF6801-(xx)-(xx) Fitting

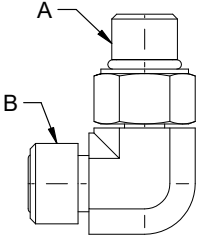

Fitting End A		O-Ring		Fitting End B		O-Ring	
SAE Fitting Size	Thread Size	AS568A Dash #	VPI Part #	SAE Fitting Size	Thread Size	AS568A Dash #	VPI Part #
-04	7/16-20	904	26.0035	-04	9/16-18	011	26.0044
-06	9/16-18	906	26.0036	-06	11/16-16	012	26.0025
-08	3/4-16	908	26.0037	-08	13/16-16	014	26.0009
-10	7/8-14	910	26.0038	-10	1-14	016	26.0023
-12	1-1/16-12	912	26.0039	-12	1-3/16-12	018	26.0045
-16	1-5/16-12	916	26.0043	-16	1-7/16-12	021	26.0046

HYDRAULICS, AXLES, & WHEELS

Blank Page

HYDRAULICS, AXLES, & WHEELS

ILLUSTRATED DRAWING Hydraulic Oil Tank

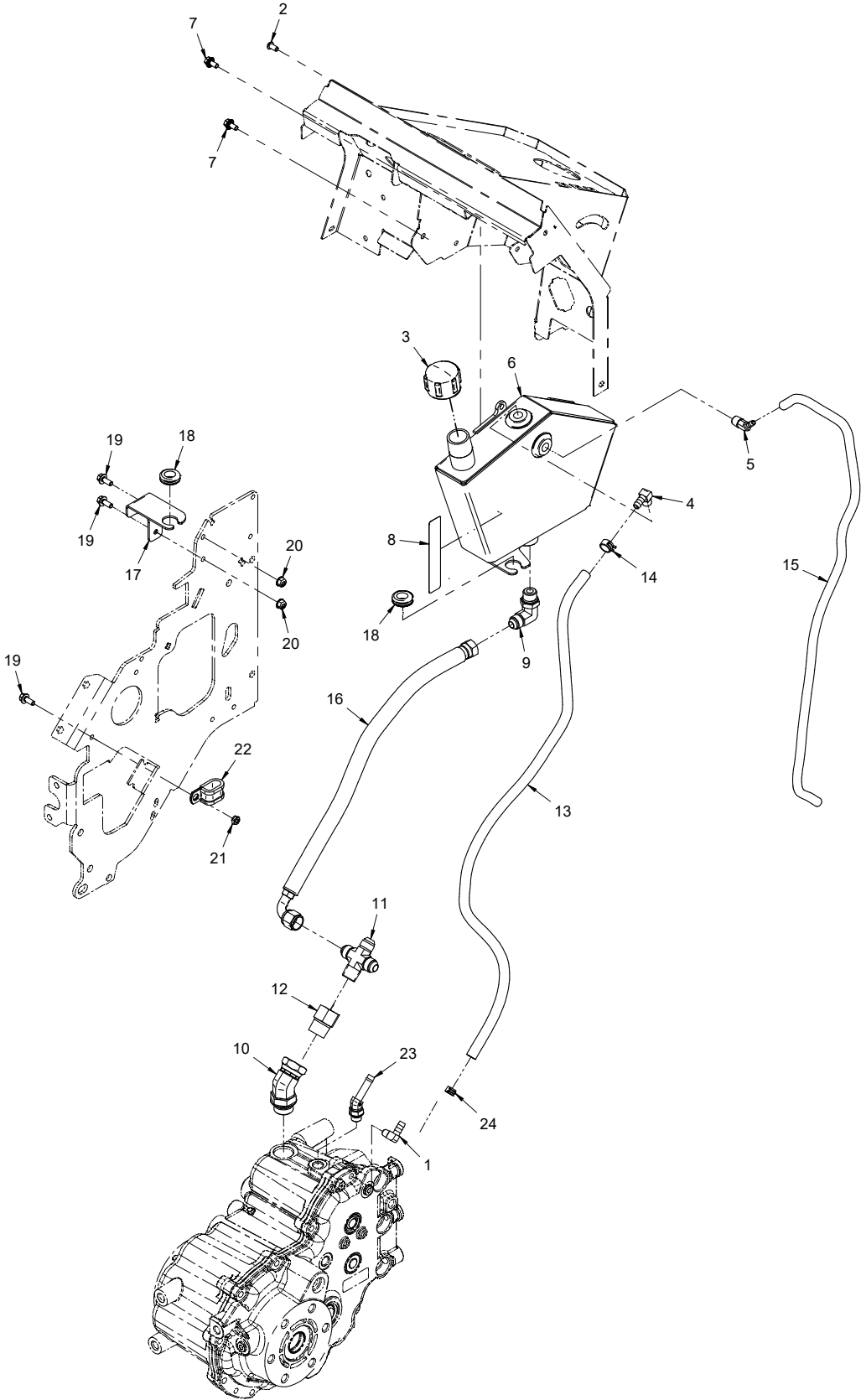

HYDRAULICS, AXLES, & WHEELS

Hydraulic Oil Tank

REF.	PART NO.	DESCRIPTION	QTY.
1	29.BF06MP0290-1	.FITTING, 3/8 BARB X 1/8 MP 90 (Serial # 01001-12728)	1
2	99.0404	.BOLT, 1/4-20 X 1/2 BSCS (Serial # 01001-15171)	1
2	99.0403	.BOLT, 1/4-20 X 3/8 BSCS (Serial # 15172-)	1
3	47.0319	.CAP, COOLANT RECOVERY TANK (Serial # 01001-15171)	1
3	29.0126	.FITTING, CAP 1" FP (Serial # 15172-)	1
4	29.BF06MP0490	.FITTING, 3/8 BARB X 1/4 MP 90	1
5	29.BF04MP0445	.FITTING, 1/4 BARB X 1/4 MP 45	1
6	47.0315	.TANK, OIL (Serial # 01001-15171)	1
6	KN-6051	.TANK, STEEL HYDRAULIC (Serial # 15172-)	1
7	99.SF0404	.BOLT, SRF 1/4-20 X 1/2 (Serial # 01001-15171)	2
7	99.SF0403	.BOLT, SRF 1/4-20 X 3/8 (Serial # 15172-)	2
8	00.0340	.DECAL, HYDRAULIC OIL	1
9	25.6801-08-08	.FITTING, 90 ELBOW LONG 8MBX8MFF	1
10	29.S4512	.PIPE, STREET 45 ELBOW 3/4 (Serial # 01001-12728)	1
10	25.6902-12-12	.FITTING, 45 MFE 3/4 X 3/4 (Serial # 12729-)	1
11	25.2651-08-08-08-08	.FITTING, CROSS 08	1
12	25.5405-12-08	.FITTING, REDUCER 3/4 X 1/2	1
13	27.T06-3-36IN	.TUBE, SILICON 3/8" ID X 36" (Serial # 01001-15171)	1
13	27.T06-3-33.5IN	.TUBE, SILICON 3/8" ID X 33-1/2" (Serial # 15172-)	1
14	11.0048	.CLAMP, HOSE BAND 9/16" OD HOSE	1
15	27.F04-30IN	.HOSE, FUEL LINE 1/4 X 30"	1
16	22.0052	.HOSE, 1/2X22.00 PLK 250PSI CPE	1
17	64.1720	.BRACKET, HOSE HOLDER (Serial # 01001-15171)	1
18	05.0140	.GROMMET, 5/8 ID, 1-1/8 OD, 3/8T	1
19	99.SF0405-1	.BOLT, SMF 1/4-20 X 5/8 (Serial # 01001-15171)	3
19	99.SF0405-1	.BOLT, SMF 1/4-20 X 5/8 (Serial # 15172-)	1
20	99.E0101	.NUT, LOCKING FLANGE 1/4-20 (Serial # 01001-15171)	2
21	99.SF04	.NUT, SRF 1/4-20 USS	1
22	11.0046	.CLAMP, CUSHIONED METAL 1/2"	1
23	25.4603-06-06	.FITTING, 45 ME 06 HB X 06 MAORB (Serial # 12729-)	1
24	11.0049	.CLAMP, HOSE BAND 1/2" OD HOSE	1

HYDRAULICS, AXLES, & WHEELS

ILLUSTRATED DRAWING Hydraulic Steering System

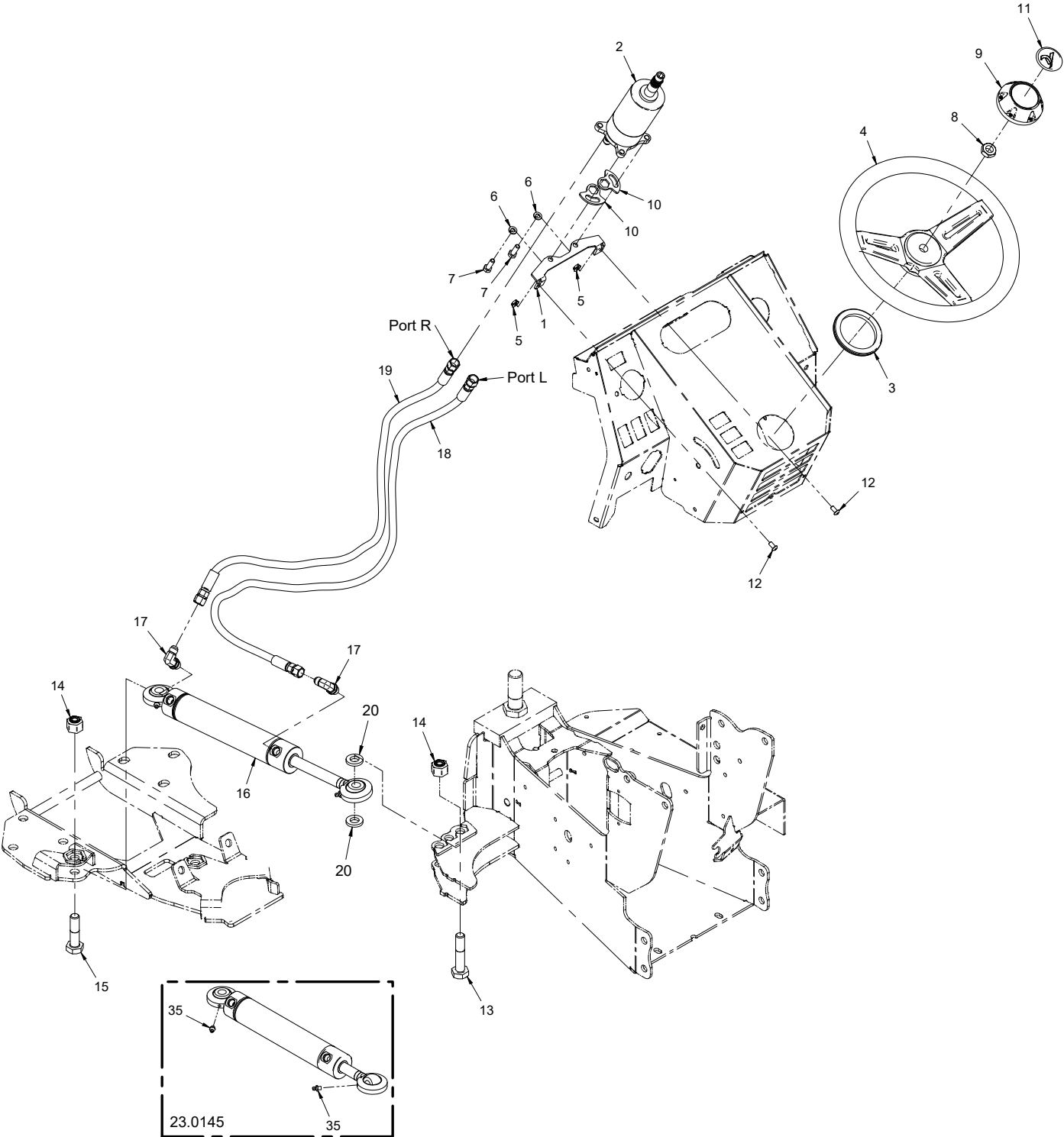

HYDRAULICS, AXLES, & WHEELS

Hydraulic Steering System

REF.	PART NO.	DESCRIPTION	QTY.
1	64.1624	.BRACKET, STEERING VALVE MT	1
2	23.0113	.VALVE, STEERING-DANFOSS 100CC	1
	89.0095	.KIT, SEAL 23.0113 STEER VALVE	1
3	05.0080	.GROMMET, 2-3/4 ID, 3-5/8 OD, 5/16T	1
4	47.0117	.STEERING WHEEL, 16MM X 40T	1
5	99.SF04	.NUT, SRF 1/4-20 USS	2
6	96.05	.WASHER, LOCK 5/16	2
7	99.M0009	.BOLT, M8 X 1.25 P X 25MM LONG	2
8	99.E0011	.NUT, JAM 5/8 SAE	1
9	47.0118	.CAP, STEERING WHEEL	1
10	64.1623	.PLATE, FITTING LOCK	2
11	00.0207	.DECAL, VENTRAC DOME	1
12	99.0404	.BOLT, 1/4-20 X 1/2 BSCS	2
13	99.K0132	.BOLT, 5/8-11 X 3 GRD A325	1
14	99.E0095	.LOCKNUT, 5/8-11 HEAVY NYLON	2
15	99.K0112	.BOLT, 5/8-11 X 2-1/2 GRD A325	1
16	23.0145	.CYLINDER, 1-3/4" X 8 STEERING	1
17	25.6801-06-06	.FITTING, 90 ME 3/8 X 3/8	2
18	20.0122	.HOSE, 1/4X43.00 SAE 100R17AR	1
19	20.0136	.HOSE, 1/4X36.00 SAE 100R17AR	1
20	64.1725	.SPACER, STEERING CYLINDER	2
35	29.GF0001	.GREASE FTG, 1/4 SAE ST	2

HYDRAULICS, AXLES, & WHEELS

ILLUSTRATED DRAWING Front Hitch Hydraulic Lift

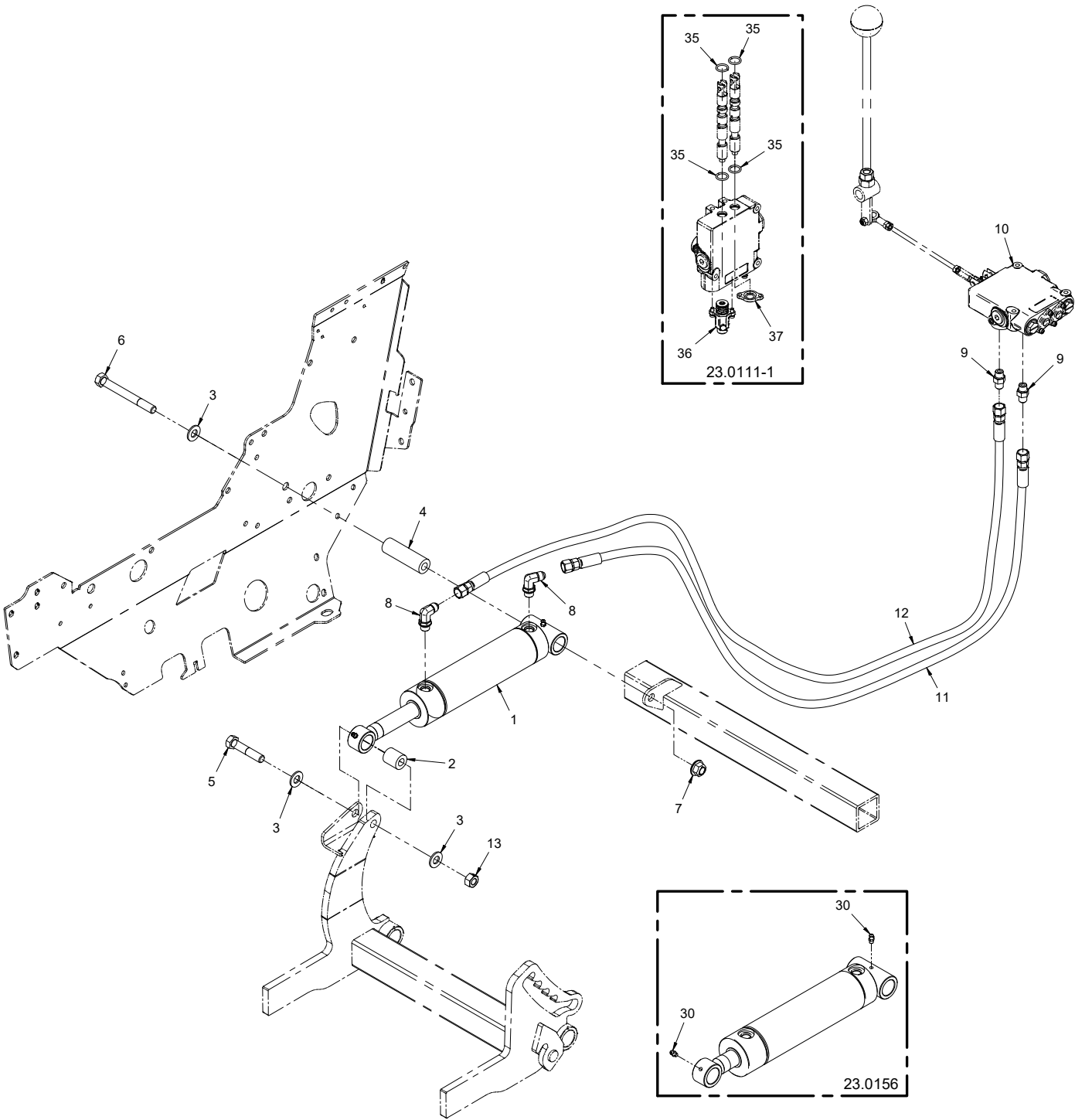

HYDRAULICS, AXLES, & WHEELS

Front Hitch Hydraulic Lift

REF.	PART NO.	DESCRIPTION	QTY.
1	23.0156	.CYLINDER, 2-1/4" X 7" LIFT	1
2	64.1712	.BUSHING, STEEL .516 X 1.000	1
3	95.08	.WASHER, FLAT 1/2 SAE	3
4	64.1631	.BUSHING, LIFT CYLINDER REAR	1
5	90.0820	.BOLT, 1/2-13 USS X 2-1/2	1
6	90.0836	.BOLT, 1/2-13 USS X 4-1/2	1
7	99.E0103	.NUT, LOCKING FLANGE 1/2-13	1
8	25.6801-06-06	.FITTING, 90 ME 3/8 X 3/8	2
9	25.6400-06-06	.FITTING, M CONN 3/8 X 3/8	2
10	23.0111-1	.VALVE, HY 2 SPL W/LH FLT, RH SP	1
11	20.0302	.HOSE, 1/4X48.00 SAE 100R17 AR	1
12	20.0303	.HOSE, 1/4X58.00 SAE 100R17 AR	1
13	99.A08C	.LOCKNUT, CENTER 1/2-13	1
30	29.GF0001	.GREASE FTG, 1/4 SAE ST	2
35	26.0027	.O-RING, 5/8ID X 13/16OD X 3/32	4
36	23.0111-7	.KIT, SPOOL FLOAT HYD. VALVE	1
37	23.0111-8	.CAP, VALVE	1

HYDRAULICS, AXLES, & WHEELS

ILLUSTRATED DRAWING Auxiliary Hydraulic Quick Couplers

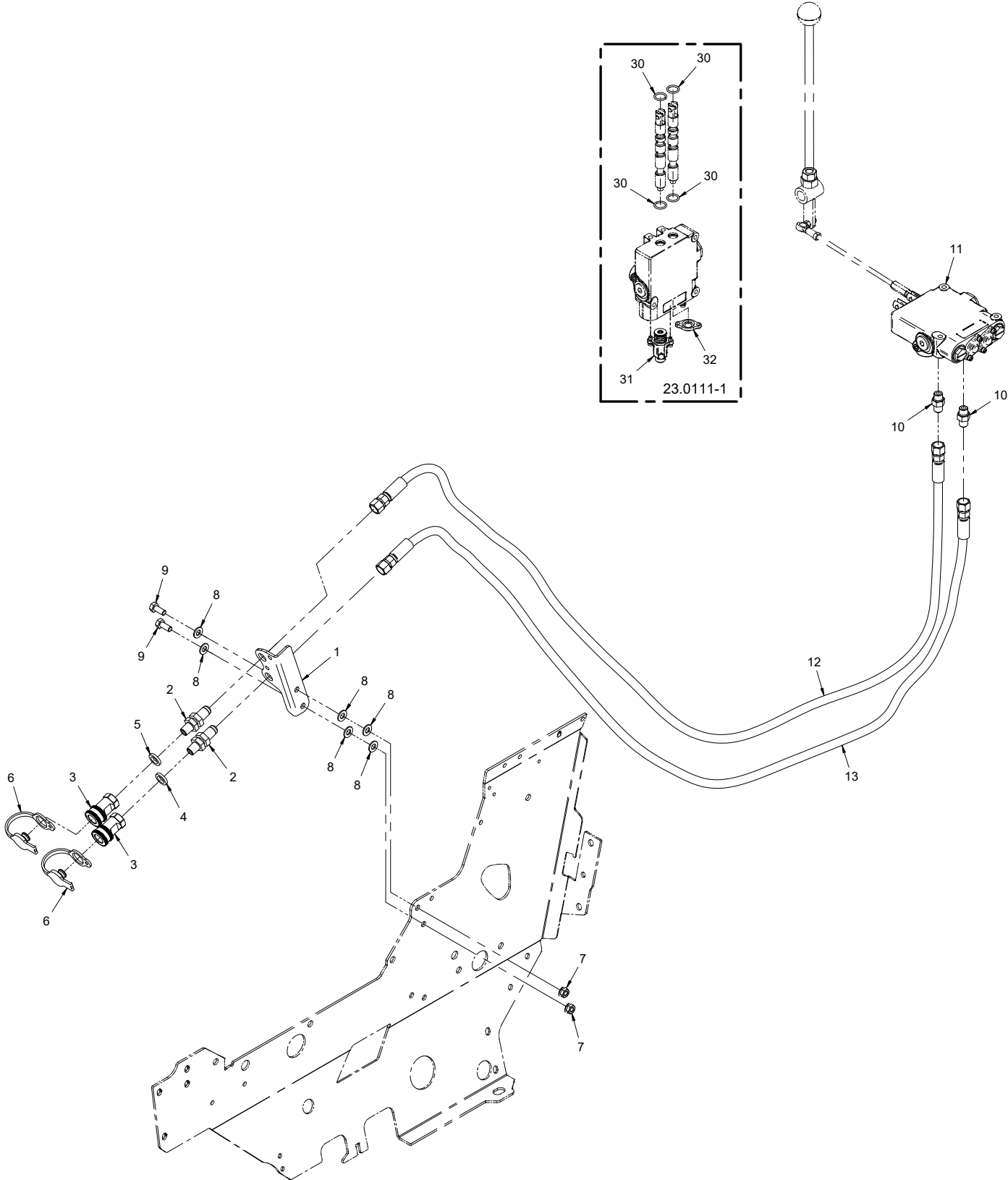

HYDRAULICS, AXLES, & WHEELS

Auxiliary Hydraulic Quick Couplers

REF.	PART NO.	DESCRIPTION	QTY.
1	64.1608	.BRACKET, HYD COUPLER 2 POS.	1
2	25.2706-04-06LN	.FITTING, BULKHEAD W/ LOCKNUT	2
3	23.0106	.COUPLER, HYDRAULIC QUICK - 1/4 FEMALE	2
4	05.0116	.WASHER, .544 ID X .817 X .14 RED	1
5	05.0117	.WASHER, .544 ID X .817 X .14 YEL	1
6	23.0126	.PLUG, DUST FOR 23.0106	2
7	99.SF05	.NUT, SRF 5/16-18 USS.	2
8	95.05	.WASHER, FLAT 5/16 SAE	6
9	90.0506	.BOLT, 5/16-18 USS X 3/4"	2
10	25.6400-06-06	.FITTING, M CONN 3/8 X 3/8	2
11	23.0111-1	.VALVE, HY 2 SPL W/LH FLT, RH SP.	1
12	20.0303	.HOSE, 1/4X58.00 SAE 100R17 AR	1
13	20.0303	.HOSE, 1/4X58.00 SAE 100R17 AR	1
30	26.0027	.O-RING, 5/8ID X 13/16OD X 3/32	4
31	23.0111-7	.KIT, SPOOL FLOAT HYD. VALVE	1
32	23.0111-8	.CAP, VALVE.	1

HYDRAULICS, AXLES, & WHEELS

ILLUSTRATED DRAWING Front Hydraulic Motor Mount & Fittings

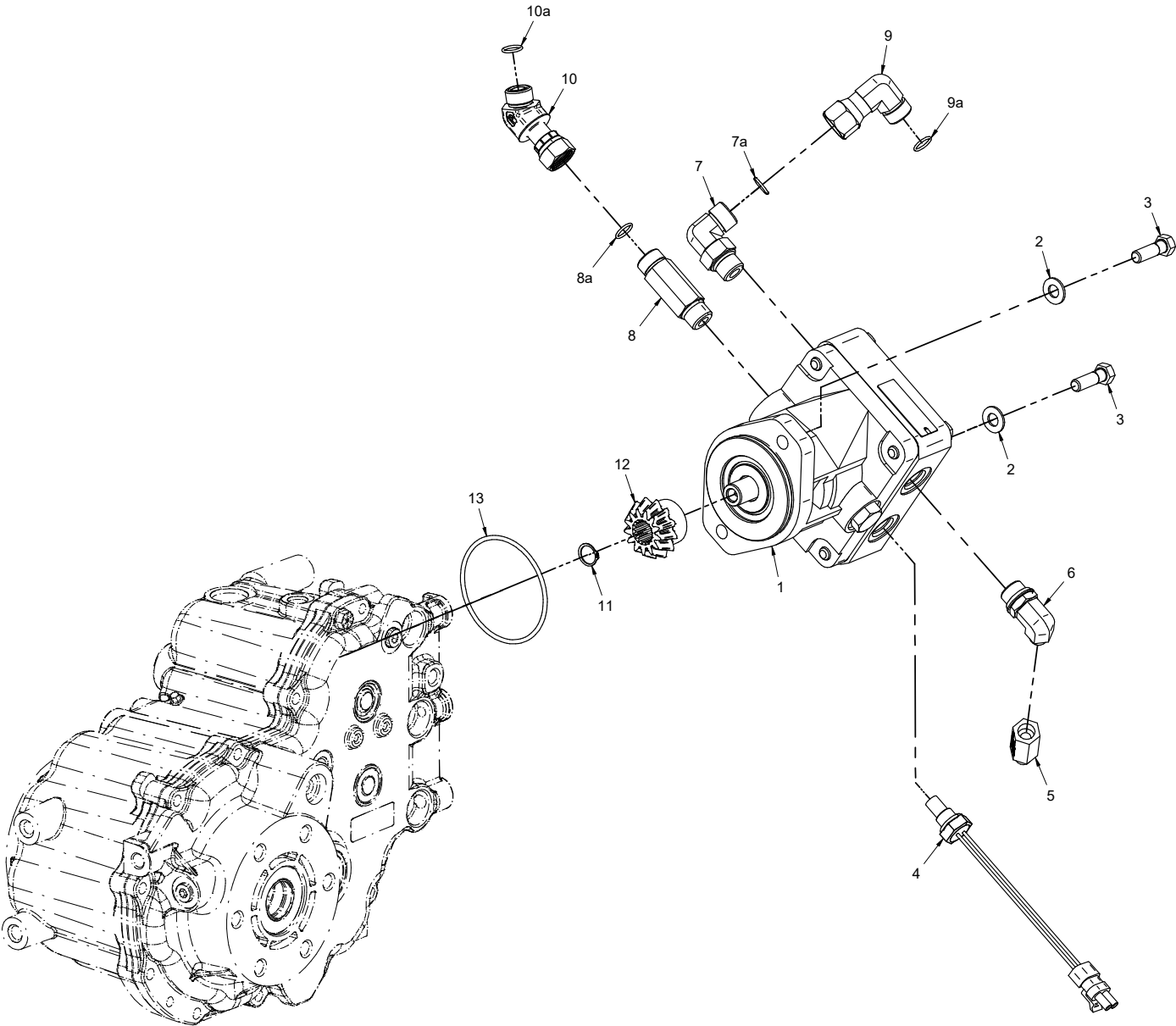

HYDRAULICS, AXLES, & WHEELS

Front Hydraulic Motor Mount & Fittings

REF.	PART NO.	DESCRIPTION	QTY.
1	21.0081*	.MOTOR, HYD. SUNDSTRAND	1
2	95.06	.WASHER, FLAT 3/8 SAE	2
3	90.0610	.BOLT, 3/8-16 USS X 1-1/4	2
4	13.0254	.SWITCH, TEMP -08 SAE ORB	1
5	23.0159	.VALVE, CHECK VONBERG	1
6	25.6801-06-08	.FITTING, 90 ME 3/8 X 1/2	1
7	25.FF6801-08-08-V	.FITTING, 90 ELBOW 8MB X 8MFF	1
7a	26.0009	.O-RING, -014 FOR MORF-08 VITON	1
8	25.FF6400-L-08-08-V	.FITTING, CONNECTOR 8MFF X 8MB	1
8a	26.0009	.O-RING, -014 FOR MORF-08 VITON	1
9	25.FF6500-08-08-V	.FITTING, 90 ELBOW 8MFF X 8FSX	1
9a	26.0009	.O-RING, -014 FOR MORF-08 VITON	1
10	25.FF6502-08-08-V	.FITTING, 45 ELBOW 8MFF X 8FFS	1
10a	26.0009	.O-RING, -014 FOR MORF-08 VITON	1
11	04.0015	.SNAP RING, EXT .039 X .588	1
12	87.0165	.GEAR, PINION MOTOR TO AXLE	1
13	26.0024	.O-RING, 3-1/8 X 3-3/8 X 1/8 (Serial # 12729-)	1

*When replacing the front motor, the shaft seal MUST be removed.

HYDRAULICS, AXLES, & WHEELS

ILLUSTRATED DRAWING Rear Hydraulic Motor Mount & Fittings

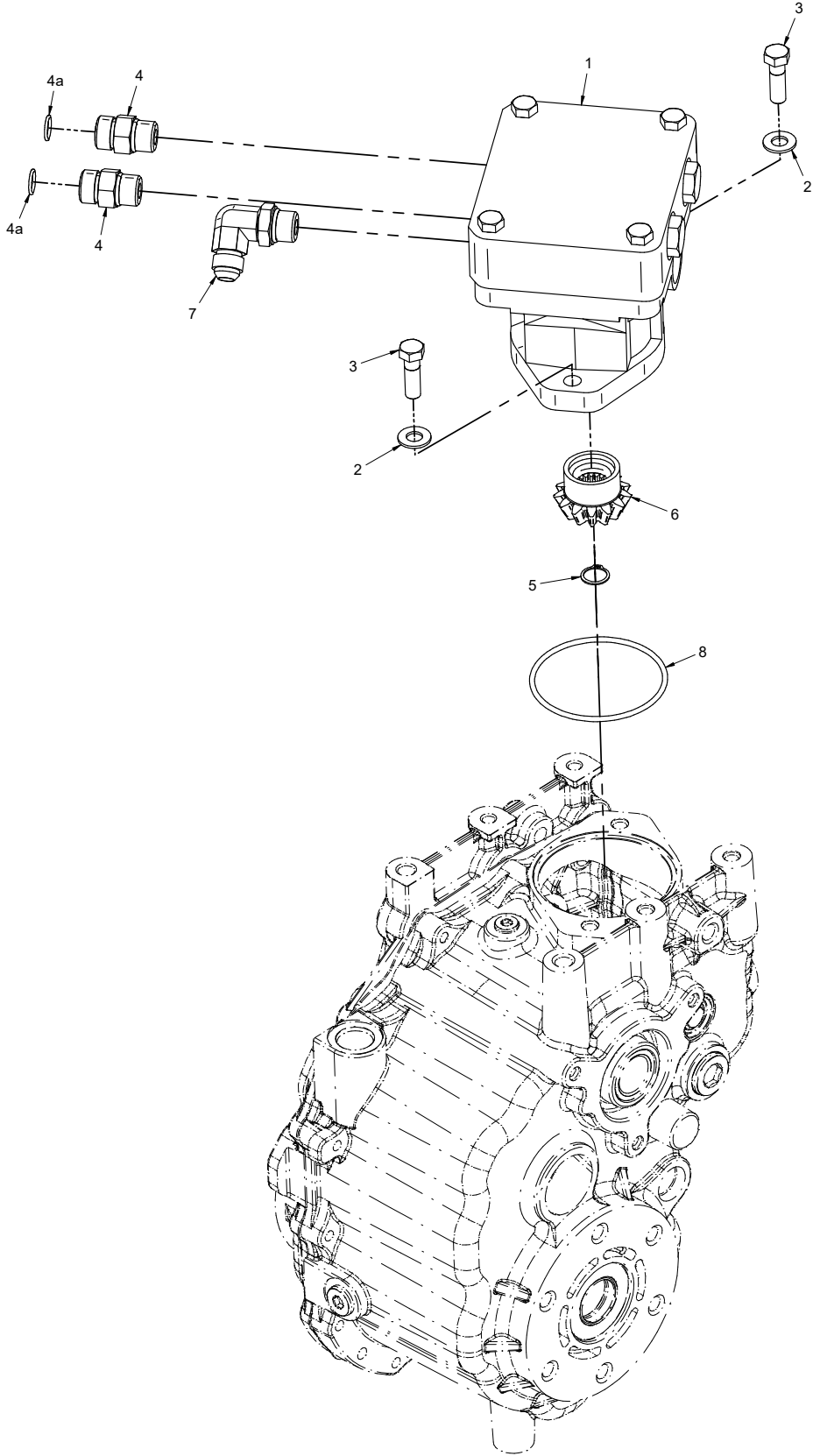

HYDRAULICS, AXLES, & WHEELS

Rear Hydraulic Motor Mount & Fittings

REF.	PART NO.	DESCRIPTION	QTY.
1	21.0081*	.MOTOR, HYD. SUNDSTRAND	1
2	95.06	.WASHER, FLAT 3/8 SAE	2
3	90.0610	.BOLT, 3/8-16 USS X 1-1/4.	2
4	25.FF6400-08-08-V	.FITTING, CONNECTOR 8MFF X 8MB	2
4a	26.0009	.O-RING, -014 FOR MORF-08 VITON	1
5	04.0015	.SNAP RING, EXT .039 X .588	1
6	87.0165	.GEAR, PINION MOTOR TO AXLE	1
7	25.6801-08-08	.FITTING, 90 ELBOW LONG 8MBX8MFF	1
8	26.0024	.O-RING, 3-1/8 X 3-3/8 X 1/8 (Serial # 12729-)	1

*When replacing the rear motor, the shaft seal MUST NOT be removed.

HYDRAULICS, AXLES, & WHEELS

ILLUSTRATED DRAWING Hydraulic Pump Mount & Fittings

If either Ref. 1 or Ref. 2 fittings need replacement, Ventrac recommends removing both Ref. 1 and Ref. 2 fittings and replacing both with a Ref. 3 fitting.

Serial # 01001-01250

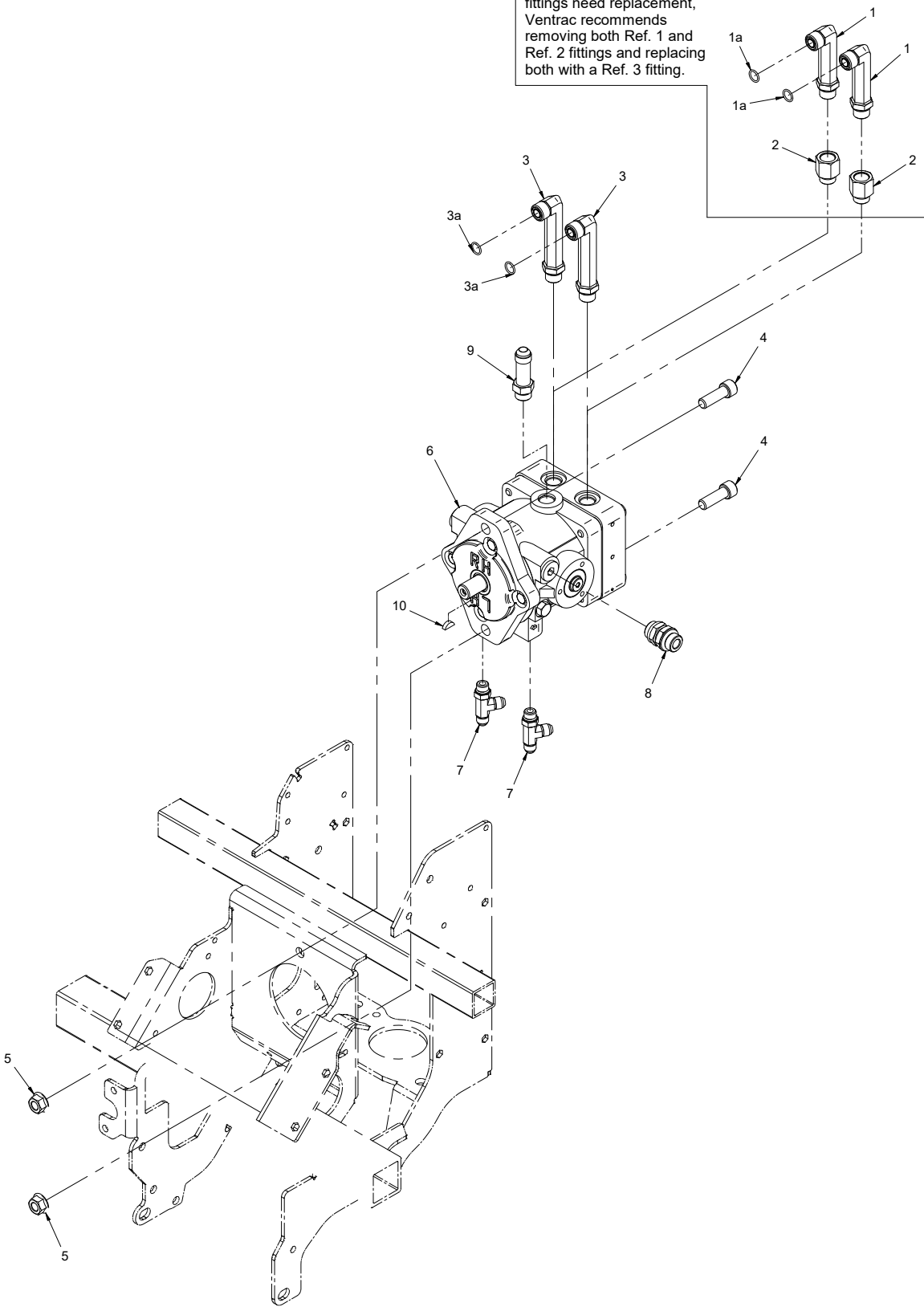

HYDRAULICS, AXLES, & WHEELS

Hydraulic Pump Mount & Fittings

REF.	PART NO.	DESCRIPTION	QTY.
1	25.FF6801-LL-08-08-V	.FITTING, 90 LBOW XLONG 8MBX8MFF (Serial # 01001-01250)	2
1a	26.0009	.O-RING, -014 FOR MORF-08 VITON	1
2	25.6410-08-08	.FITTING, REDUCER 08MB X 08FB (Serial # 01001-01250)	2
3	25.FF6801-4.415-08-08-V	.FITTING, 90 LBOW XLNG 8MBX8MFF (Serial # 01251-)	2
3a	26.0009	.O-RING, -014 FOR MORF-08 VITON	1
4	99.K0039	.BOLT, SHCS 1/2 X 1 1/2	2
5	99.SF08	.NUT, SRF 1/2-13 USS	2
6	21.0080	.PUMP, HYDRAULIC	1
7	25.6804-6-6-6	.FITTING, M TEE 3/8X3/8X3/8	2
8	25.6407-10-10	.FITTING, M. ADAPTER -10 X -10	1
9	25.6400-L-08-08	.FITTING, CONNECTOR 8MJ X 8MB	1
10	85.W0305	.KEY, WOODRUFF 3/16" X 5/8"	1

HYDRAULICS, AXLES, & WHEELS

ILLUSTRATED DRAWING Hydraulic Oil Cooler & Fan

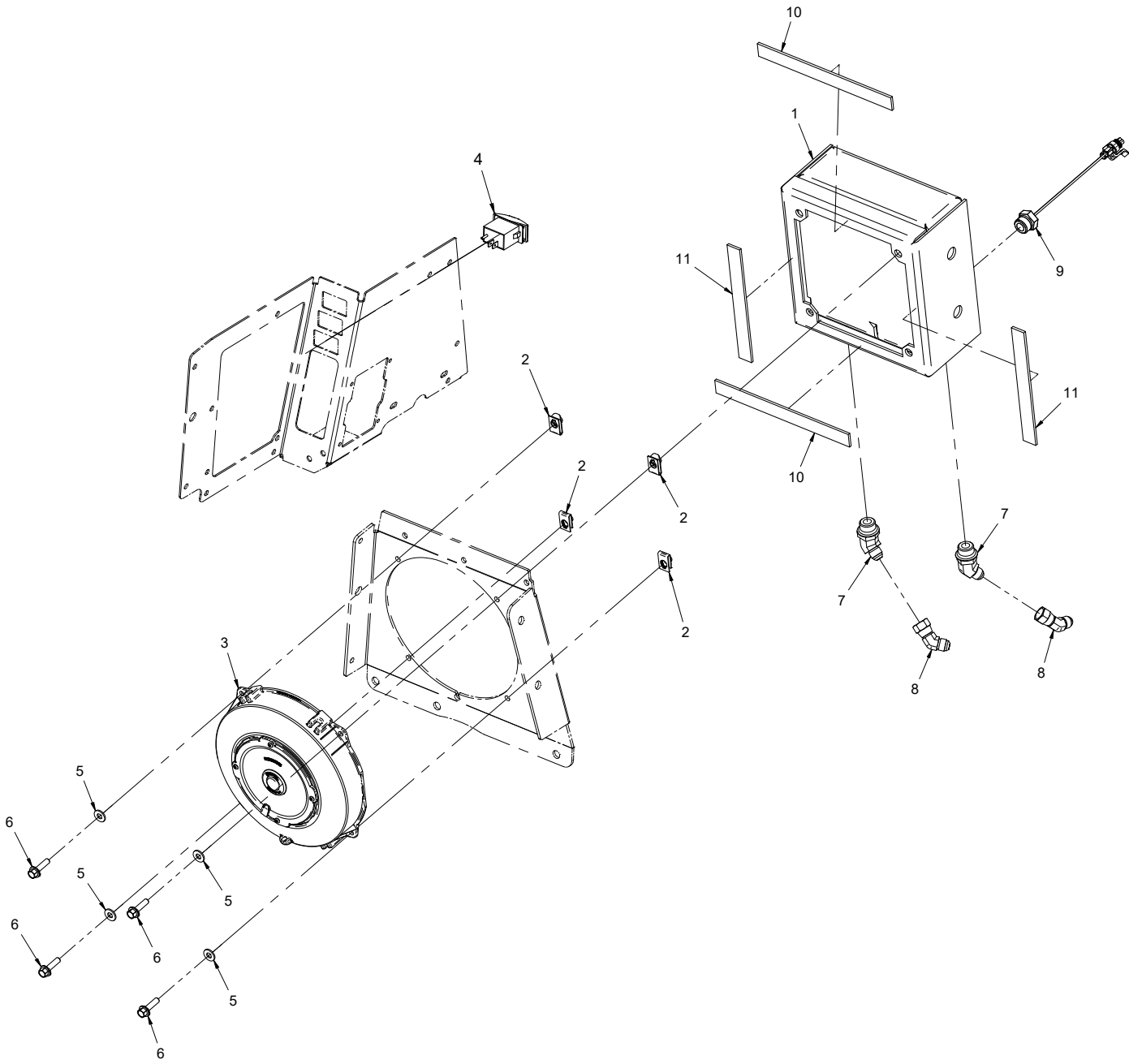

HYDRAULICS, AXLES, & WHEELS

Hydraulic Oil Cooler & Fan

REF.	PART NO.	DESCRIPTION	QTY.
1	21.0121	.COOLER, HYDRAULIC	1
2	99.E0046	.NUT, "U" 1/4-20 EXTRUDED	4
3	37.0057	.FAN, ELECTRIC 7.5"	1
4	31.0053	.SWITCH, ROCKER ON/OFF	1
5	95.04	.WASHER, FLAT 1/4 SAE	4
6	99.SF0408	.BOLT, SRF 1/4 X 1 USS	4
7	25.6802-06-08	.FITTING, 45 ME 3/8 X 1/2	2
8	25.6502-06-06	.FITTING, 45 MFE 3/8 X 3/8	2
9	13.0239	.SWITCH, TEMPERATURE 170F	1
10	06.0045-8IN	.WEATHERSTRIP, 1/8 X 3/4 X 8"	2
11	06.0045-6.75IN	.WEATHERSTRIP, 1/8 X 3/4 X 6-3/4"	2

HYDRAULICS, AXLES, & WHEELS

ILLUSTRATED DRAWING Hydraulic Drive Circuit Hoses

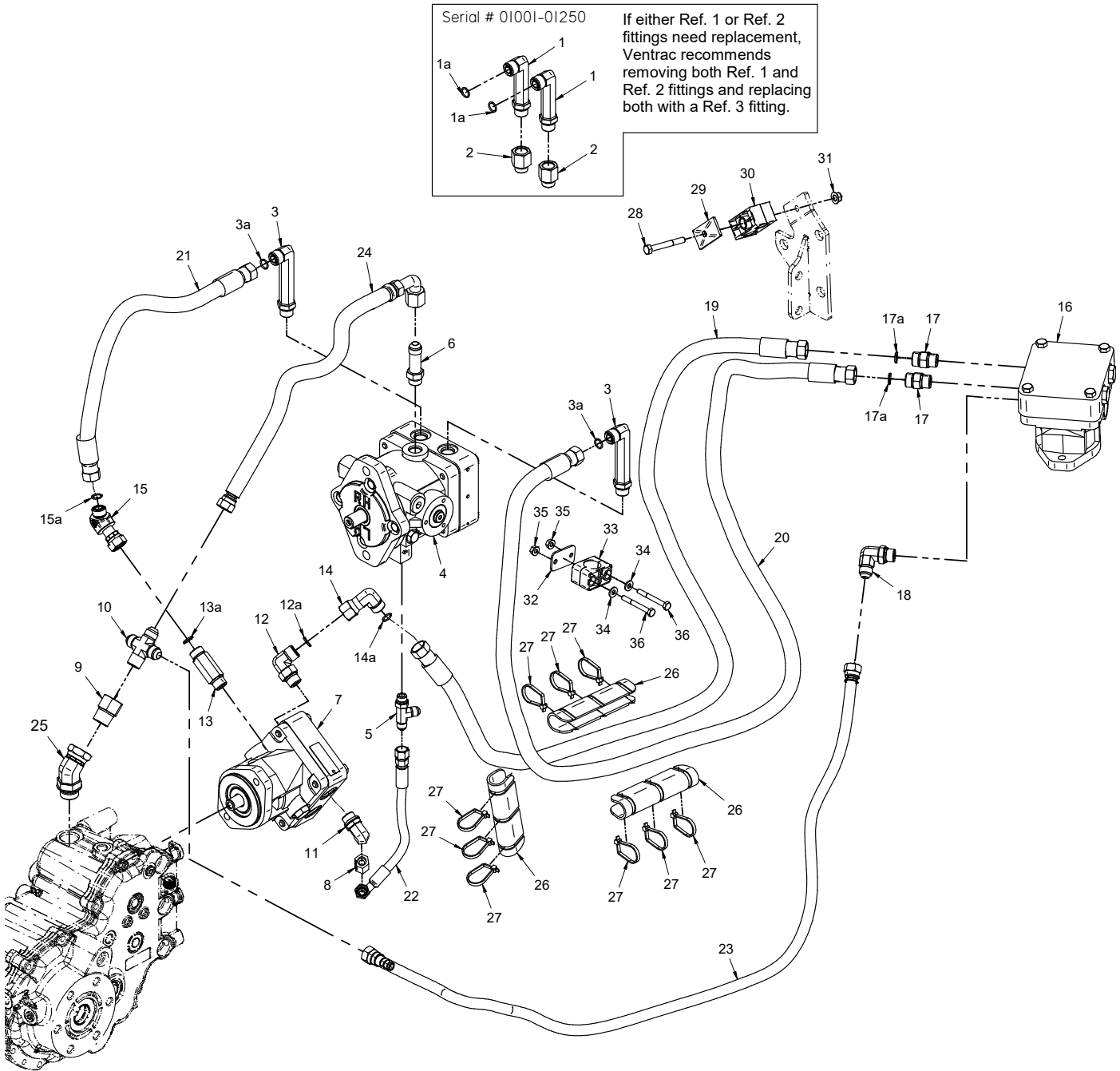

HYDRAULICS, AXLES, & WHEELS

Hydraulic Drive Circuit Hoses

REF.	PART NO.	DESCRIPTION	QTY.
1	25.FF6801-LL-08-08-V	.FITTING, 90 LBOW XLONG 8MBX8MFF (Serial # 01001-01250)	2
1a	26.0009	.O-RING, -014 FOR MORF-08 VITON	1
2	25.6410-08-08	.FITTING, REDUCER 08MB X 08FB (Serial # 01001-01250)	2
3	25.FF6801-4.415-08-08-V	.FITTING, 90 LBOW XLNG 8MBX8MFF (Serial # 01251-)	2
3a	26.0009	.O-RING, -014 FOR MORF-08 VITON	1
4	21.0080	.PUMP, HYDRAULIC	1
5	25.6804-6-6-6	.FITTING, M TEE 3/8X3/8X3/8	1
6	25.6400-L-08-08	.FITTING, CONNECTOR 8MJ X 8MB	1
7	21.0081*	.MOTOR, HYD. SUNDSTRAND	1
8	23.0159	.VALVE, CHECK VONBERG	1
9	25.5405-12-08	.FITTING, REDUCER 3/4 X 1/2	1
10	25.2651-08-08-08-08	.FITTING, CROSS 08	1
11	25.6801-06-08	.FITTING, 90 ME 3/8 X 1/2	1
12	25.FF6801-08-08-V	.FITTING, 90 ELBOW 8MB X 8MFF	1
12a	26.0009	.O-RING, -014 FOR MORF-08 VITON	1
13	25.FF6400-L-08-08-V	.FITTING, CONNECTOR 8MFF X 8MB	1
13a	26.0009	.O-RING, -014 FOR MORF-08 VITON	1
14	25.FF6500-08-08-V	.FITTING, 90 ELBOW 8MFF X 8FSX	1
14a	26.0009	.O-RING, -014 FOR MORF-08 VITON	1
15	25.FF6502-08-08-V	.FITTING, 45 ELBOW 8MFF X 8FFS	1
15a	26.0009	.O-RING, -014 FOR MORF-08 VITON	1
16	21.0081*	.MOTOR, HYD. SUNDSTRAND	1
17	25.FF6400-08-08-V	.FITTING, CONNECTOR 8MFF X 8MB	2
17a	26.0009	.O-RING, -014 FOR MORF-08 VITON	1
18	25.6801-08-08	.FITTING, 90 ELBOW LONG 8MBX8MFF	1
19	20.0295	.HOSE, 1/2X55.00 SS BRAID PTFE	1
20	20.0296	.HOSE, 1/2X74.50 SS BRAID PTFE	1
21	20.0297	.HOSE, 1/2X18.38 SS BRAID PTFE	1
22	20.0304	.HOSE 1/4X20.50 SAE 100R17 AR	1
23	22.0058	.HOSE, 3/8X54.00 PLK 250PSI CPE	1
24	22.0059	.HOSE, 1/2X17.00 PLK 250PSI CPE	1
25	29.S4512	.PIPE, STREET 45 ELBOW 3/4 (Serial # 01001-12728)	1
25	25.6902-12-12	.FITTING, 45 MFE 3/4 X 3/4 (Serial # 12729-)	1
26	44.0224	.SLEEVE, HOSE PROTECTOR 6"	3
27	30.0204	.TYTON TIE, #50 .190 X 12"	9
28	90.0520	.BOLT, 5/16-18 USS X 2-1/2"	1
29	44.0249	.COVER PLATE, 3D GROUP	1
30	44.0248	.CLAMP, HYD HOSE 21.3MM ID BLACK	1
31	99.E0102	.NUT, LOCKING FLANGE 5/16-18	1
32	44.0321	.COVER PLATE, GROUP 3 (1)	1
33	44.0320	.CLAMP, HYD HOSE 25.4MM ID	1
34	95.04	.WASHER, FLAT 1/4 SAE	2
35	99.E0101	.NUT, LOCKING FLANGE 1/4-20	2
36	90.0418	.BOLT, 1/4-20 USS X 2-1/4"	2

*When replacing the front motor, the shaft seal MUST be removed.
When replacing the rear motor, the shaft seal MUST NOT be removed.

HYDRAULICS, AXLES, & WHEELS

ILLUSTRATED DRAWING Pump Supply Line & Main Hydraulic Filter

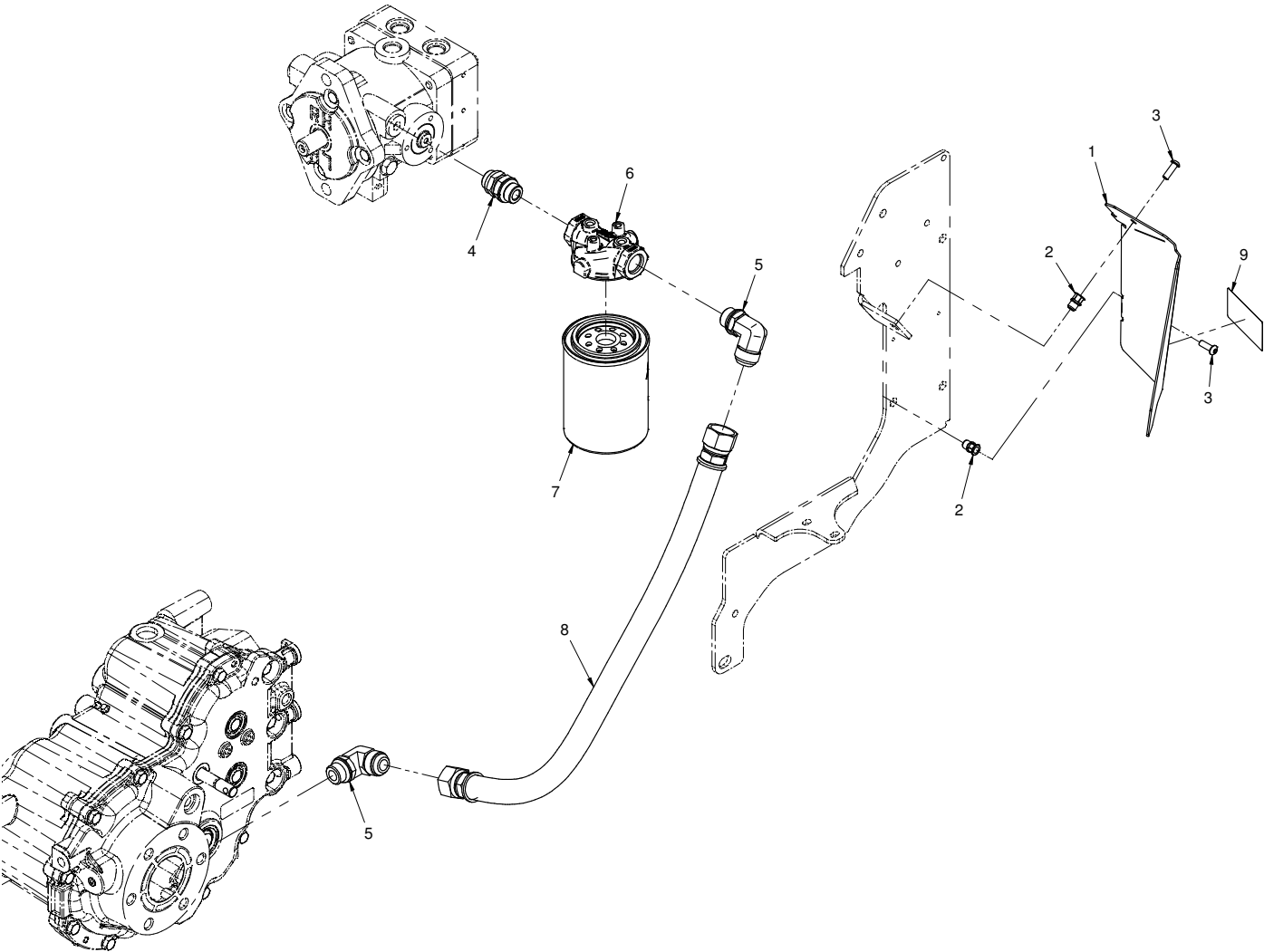

HYDRAULICS, AXLES, & WHEELS

Pump Supply Line & Main Hydraulic Filter

REF.	PART NO.	DESCRIPTION	QTY.
1	60.1154	.COVER, HYD FILTER ACCESS	1
2	99.E0105	.NUT, INSERT 1/4-20 HEX	2
3	99.0406	.BOLT, 1/4-20 X 3/4 BSCS	2
4	25.6407-10-10	.FITTING, M. ADAPTER -10 X -10	1
5	25.6801-12-10	.FITTING, 90 ME 3/4 X 5/8	2
6	21.0119	.FILTER, HEAD -10 ORB PORTS	1
7	21.0122	.FILTER, HYD. 25 MICRON SYN	1
8	22.0050	.HOSE, 3/4X22.00 PLK 250PSI CPE	1
9	00.0518	.DECAL, HYDRAULIC FILTER LOCATION	1

HYDRAULICS, AXLES, & WHEELS

ILLUSTRATED DRAWING Hydraulic Implement Circuit Supply & Return

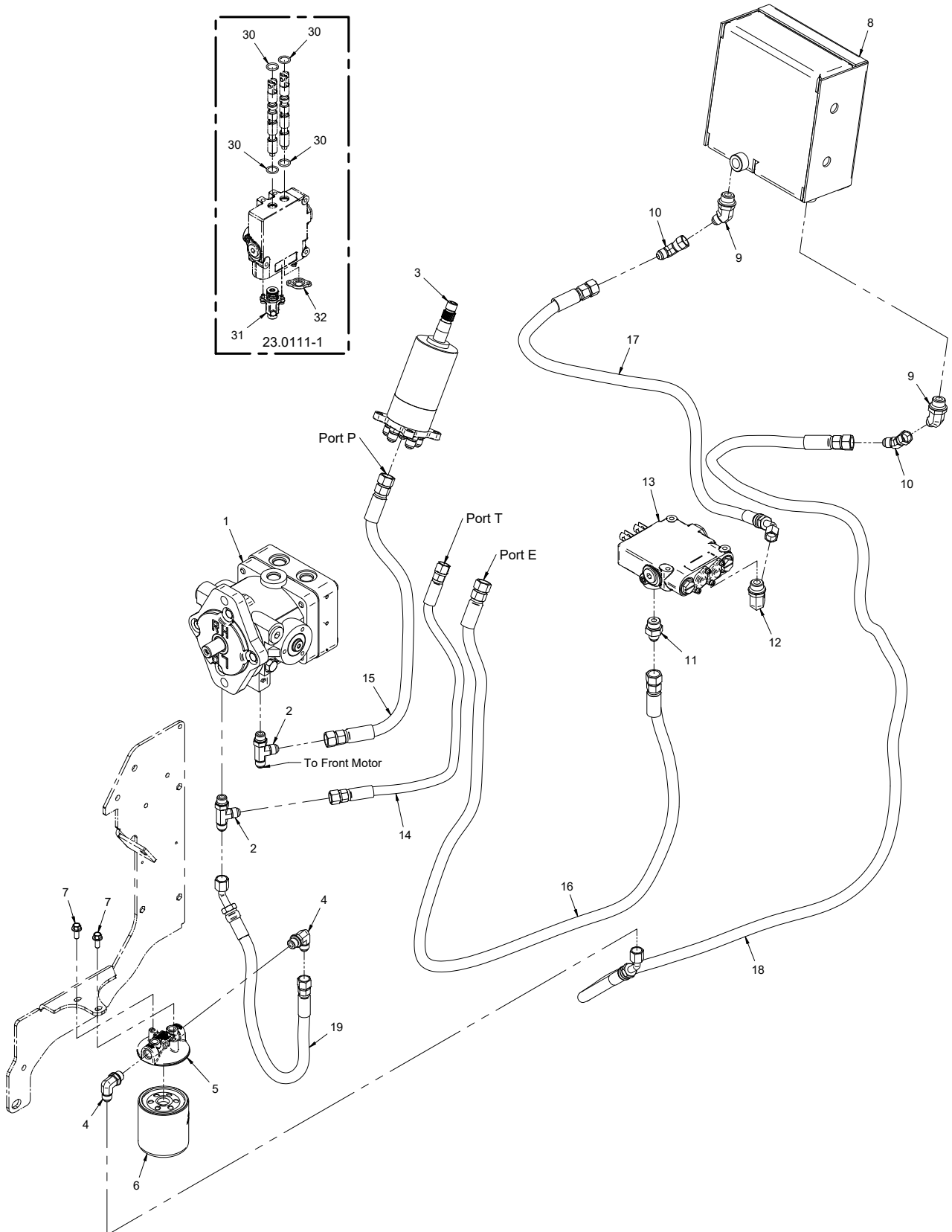

HYDRAULICS, AXLES, & WHEELS

Hydraulic Implement Circuit Supply & Return

REF.	PART NO.	DESCRIPTION	QTY.
1	21.0080	.PUMP, HYDRAULIC	1
2	25.6804-6-6-6	.FITTING, M TEE 3/8X3/8X3/8	2
3	23.0113	.VALVE, STEERING-DANFOSS 100CC.	1
	89.0095	.KIT, SEAL 23.0113 STEER VALVE	1
4	25.6801-06-06	.FITTING, 90 ME 3/8 X 3/8.	2
5	21.0123	.FILTER, HEAD 06 ORB	1
6	21.0124	.FILTER, HYD. 10 MICRON CEL.	1
7	99.SF0405-1	.BOLT, SMF 1/4-20 X 5/8	2
8	21.0121	.COOLER, HYDRAULIC	1
9	25.6802-06-08	.FITTING, 45 ME 3/8 X 1/2.	2
10	25.6502-06-06	.FITTING, 45 MFE 3/8 X 3/8	2
11	25.6400-06-08	.FITTING, M CONN 3/8 X 1/2	1
12	25.6801-06-08	.FITTING, 90 ME 3/8 X 1/2.	1
13	23.0111-1	.VALVE, HY 2 SPL W/LH FLT, RH SP.	1
14	20.0123	.HOSE, 1/4X19.50 SAE 100R17AR.	1
15	20.0155	.HOSE, 3/8X19.00 SAE 100R17AR.	1
16	20.0298	.HOSE, 3/8X56.00 SAE 100R17 AR	1
17	20.0299	.HOSE, 3/8X32.00 SAE 100R17 AR	1
18	20.0300	.HOSE, 3/8X69.00 SAE 100R17 AR	1
19	20.0301	.HOSE, 3/8X20.00 SAE 100R17 AR	1
30	26.0027	.O-RING, 5/8ID X 13/16OD X 3/32	4
31	23.0111-7	.KIT, SPOOL FLOAT HYD. VALVE	1
32	23.0111-8	.CAP, VALVE.	1

HYDRAULICS, AXLES, & WHEELS

ILLUSTRATED DRAWING Front Transaxle & Wheels

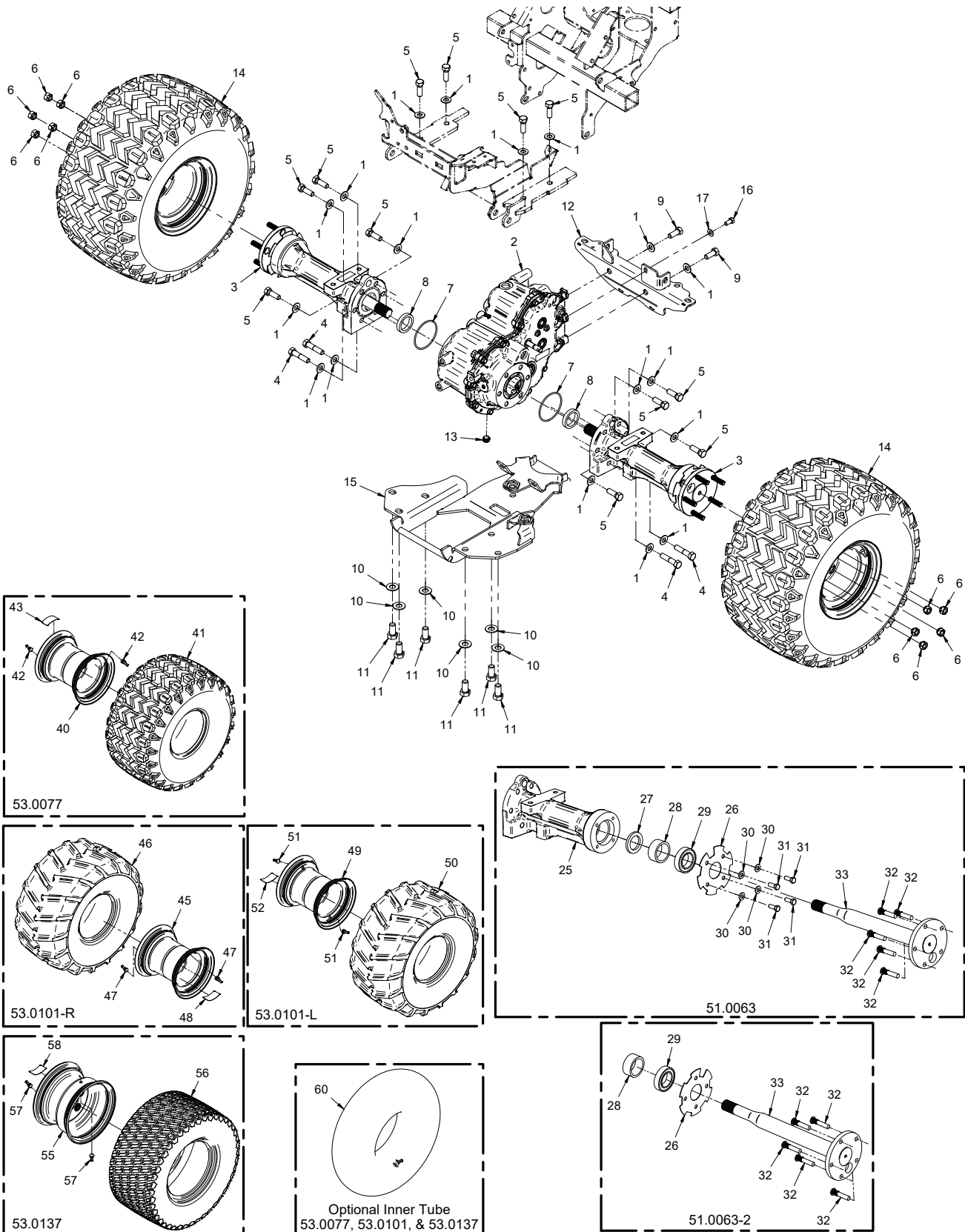

HYDRAULICS, AXLES, & WHEELS

Front Transaxle & Wheels

REF.	PART NO.	DESCRIPTION	QTY.
1	95.08	.WASHER, FLAT 1/2 SAE	18
2	51.0020	.TRANSAXLE, PEERLESS (Serial # 01001-12728)	1
2	51.0087	.TRANSAXLE, PEERLESS (Serial # 12729-)	1
3	51.0063	.AXLE, ASM 40MM FORGED SHAFT	2
4	90.0818	.BOLT, 1/2-13 USS X 2-1/4	4
5	90.0812	.BOLT, 1/2-13 USS X 1-1/2	12
6	99.E0044	.NUT, LUG 7/16-20 SAE	10
7	26.0024	.O-RING 3-1/8 X 3-3/8 X 1/8	2
8	51.0022	.SPACER, AXLE FOR HOUSING ASSY	2
9	90.0810	.BOLT, 1/2-13 USS X 1-1/4	2
10	95.10	.WASHER, FLAT 5/8 SAE	6
11	90.1010	.BOLT, 5/8-11 USS X 1-1/4	6
12	64.1613	.BRACKET, CONNECTOR FRAME MT (Serial # 01001-03011)	1
12	64.1863	.BRACKET, CONNECTOR FRAME MT (Serial # 03012-)	1
13	29.P06H	.PIPE, PLUG 3/8 HEX ZP (Serial # 01001-12728)	1
14	53.0077	.WHEEL, ASM 22 X 12 X 8 X 5B	2
15	62.1371	.FRAME, CONNECTOR LINK MOUNT	1
16	90.0606	.BOLT, 3/8-16 USS X 3/4 (Serial # 03012-)	1
17	95.06	.WASHER, FLAT 3/8 SAE (Serial # 03012-)	1
25	51.0063-1	.HOUSING, AXLE PEERLESS KT	1
26	51.0063-4	.PLATE, COVER PEERLESS AXLE	1
27	89.0074	.SEAL, OIL PEERLESS AXLE 51.0063	1
28	51.0063-3	.SPACER, AXLE PEERLESS KT	1
29	55.0063	.BEARING, AXLE PEERLESS 51.0063	1
30	95.06	.WASHER, FLAT 3/8 SAE	4
31	90.0608	.BOLT, 3/8-16 USS X 1	4
32	99.K0100	.BOLT, WHL/STD 7/16-20 X 2-1/8	5
33	51.0063-2	.SHAFT, AXLE ASM PEERLESS	1
40	53.0090	.RIM, 8 X 8.5, 5 ON 4.5 BC	1
41	53.0089	.TIRE, FIELD 22 X 12 X 8-NO RIM	1
42	53.0139	.VALVE STEM	2
43	00.0348	.DECAL, WARNING HUB SIDE (Serial # 01001-14497)	1
43	00.0645	.DECAL, HUB SIDE (Serial # 14498-)	1
45	53.0090	.RIM, 8 X 8.5, 5 ON 4.5 BC	1
46	53.0114	.TIRE, BAR 21X11X8 NO RIM	1
47	53.0139	.VALVE STEM	2
48	00.0348	.DECAL, WARNING HUB SIDE (Serial # 01001-14497)	1
48	00.0645	.DECAL, HUB SIDE (Serial # 14498-)	1
49	53.0090	.RIM, 8 X 8.5, 5 ON 4.5 BC	1
50	53.0114	.TIRE, BAR 21X11X8 NO RIM	1
51	53.0139	.VALVE STEM	2
52	00.0348	.DECAL, WARNING HUB SIDE (Serial # 01001-14497)	1
52	00.0645	.DECAL, HUB SIDE (Serial # 14498-)	1
55	53.0138	.RIM, 10 X 7 - 5 ON 4.5 BC	1
56	53.0112	.TIRE, TURFMASTR 22X11X10 NO RIM	1
57	53.0139	.VALVE STEM	2
58	00.0348	.DECAL, WARNING HUB SIDE (Serial # 01001-14497)	1
58	00.0645	.DECAL, HUB SIDE (Serial # 14498-)	1
60	53.0142	.TUBE, INNER 22 X 12 X 8	4

HYDRAULICS, AXLES, & WHEELS

ILLUSTRATED DRAWING Rear Transaxle & Wheels

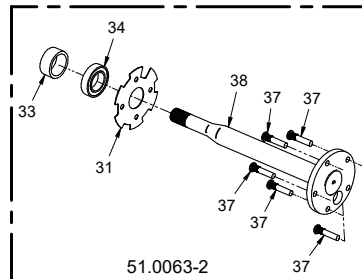
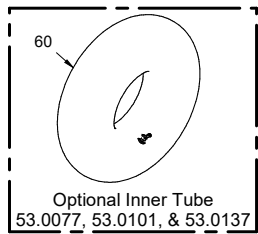
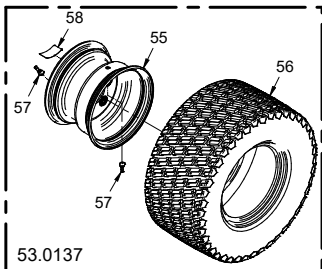
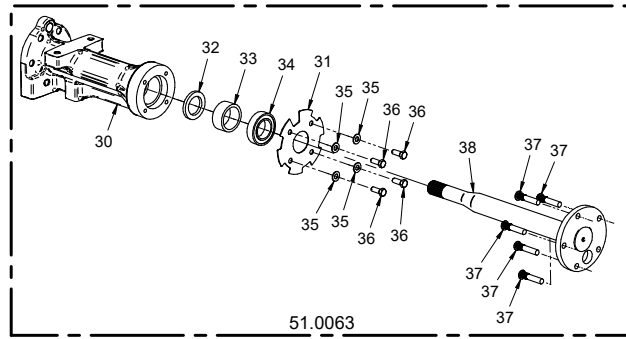
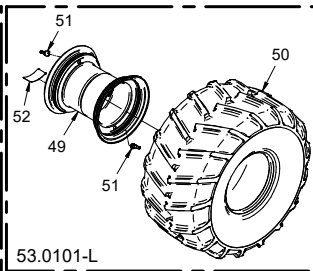
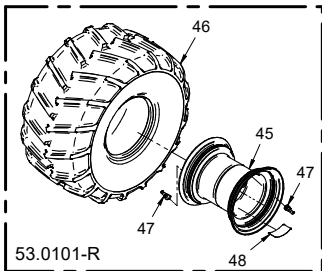
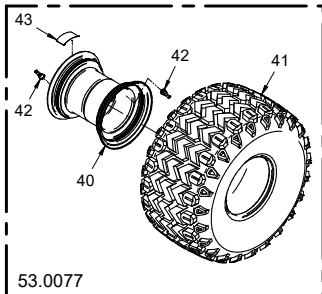
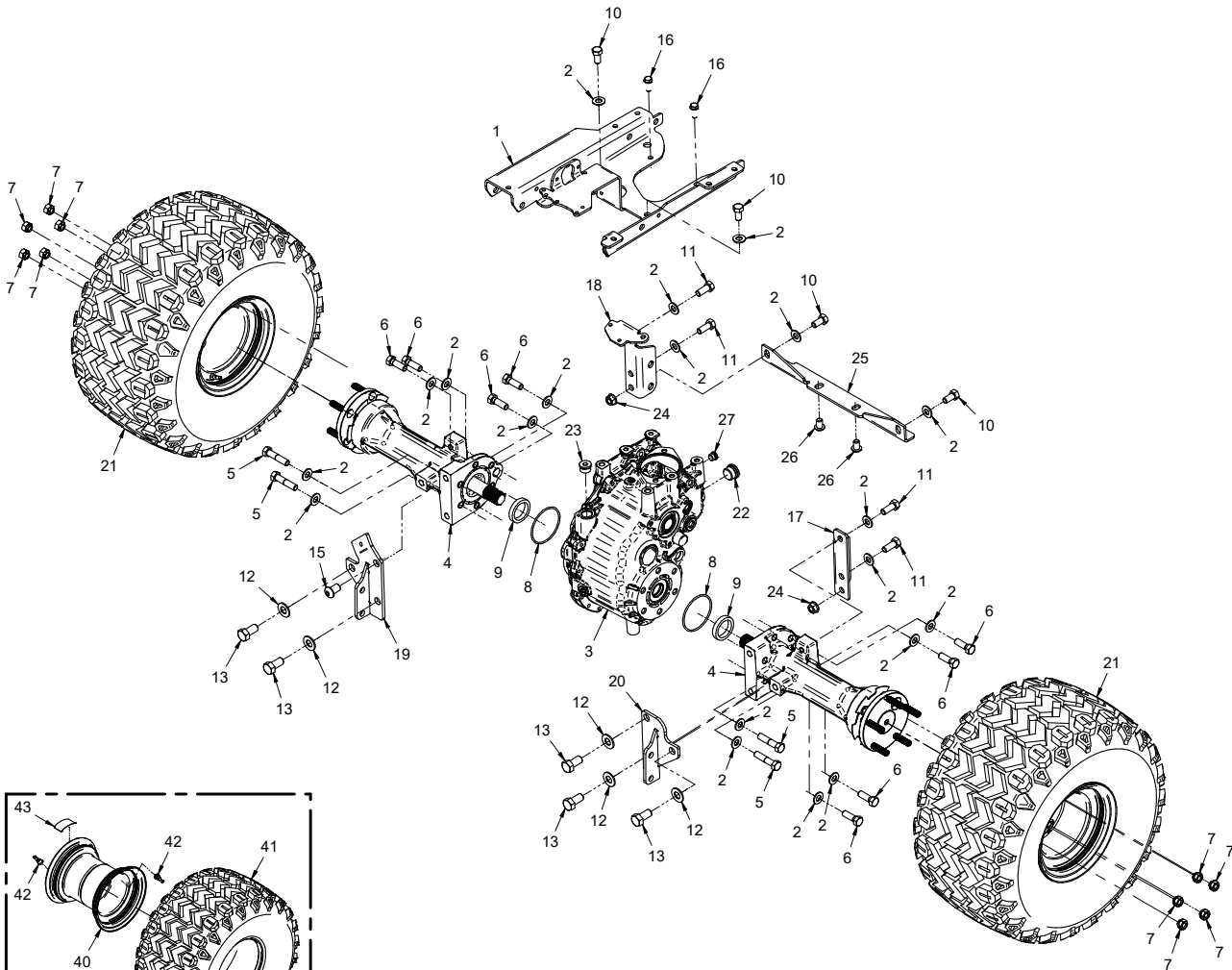

HYDRAULICS, AXLES, & WHEELS

Rear Transaxle & Wheels

REF.	PART NO.	DESCRIPTION	QTY.
1	62.1368	.FRAME, REAR UPPER (Serial # 01001-01374)	1
1	62.1394	.FRAME, REAR UPPER (Serial # 01375-)	1
2	95.08	.WASHER, FLAT 1/2 SAE	20
3	51.0020	.TRANSAXLE, PEERLESS (Serial # 01001-12728)	1
3	51.0087	.TRANSAXLE, PEERLESS (Serial # 12729-)	1
4	51.0063	.AXLE, ASM 40MM FORGED SHAFT	2
5	90.0818	.BOLT, 1/2-13 USS X 2-1/4	4
6	90.0812	.BOLT, 1/2-13 USS X 1 1/2	8
7	99.E0044	.NUT, LUG 7/16-20 SAE	10
8	26.0024	.O-RING 3-1/8 X 3-3/8 X 1/8	2
9	51.0022	.SPACER, AXLE FOR HOUSING ASSY	2
10	90.0808	.BOLT, 1/2-13 USS X 1	4
11	90.0810	.BOLT, 1/2-13 USS X 1-1/4	4
12	95.10	.WASHER, FLAT 5/8 SAE	5
13	90.1010	.BOLT, 5/8-11 USS X 1 1/4	5
15	99.1008	.BOLT, 5/8-11 X 1 BSCS	1
16	99.SF0608	.BOLT, SRF 3/8-16 USS X 1	2
17	64.1592	.BRACKET, REAR HITCH MT LEFT (Serial # 01001-02923)	1
17	64.1865	.BRACKET, REAR HITCH MT LEFT (Serial # 02924-)	1
18	64.1591	.BRACKET, REAR HITCH MT RIGHT (Serial # 01001-02923)	1
18	64.1866	.BRACKET, REAR HITCH MT RIGHT (Serial # 02924-)	1
19	64.1595	.BRACKET, TRANSAXLE MOUNT RIGHT	1
20	64.1594	.BRACKET, TRANSAXLE MOUNT LEFT	1
21	53.0077	.WHEEL, ASM 22 X 12 X 8 X 5B	2
22	29.P12G	.PIPE, PLUG 3/4" GALV. SQ ZP (Serial # 01001-12728)	1
22	25.6408-H-12	.FITTING, PLUG 12MB X HOLLOW ALLEN (Serial # 12729-)	1
23	25.6408-H-10	.FITTING, -10 MB X HOLLOW ALLEN	1
24	99.SF08	.NUT, SRF 1/2-13 USS (Serial # 02924-)	2
25	64.1864	.BRACKET, REAR TRANSAXLE (Serial # 02924-)	1
26	99.0806	.BOLT, 1/2-13 X 3/4 BSCS (Serial # 02924-)	2
27	25.6408-H-06	.FITTING, PLUG 06MB X HOLLOW ALLEN (Serial # 12729-)	1
30	51.0063-1	.HOUSING, AXLE PEERLESS KT	1
31	51.0063-4	.PLATE, COVER PEERLESS AXLE	1
32	89.0074	.SEAL, OIL PEERLESS AXLE 51.0063	1
33	51.0063-3	.SPACER, AXLE PEERLESS KT	1
34	55.0063	.BEARING, AXLE PEERLESS 51.0063	1
35	95.06	.WASHER, FLAT 3/8 SAE	4
36	90.0608	.BOLT, 3/8-16 USS X 1	4
37	99.K0100	.BOLT, WHL/STD 7/16-20 X 2-1/8	5
38	51.0063-2	.SHAFT, AXLE ASM PEERLESS	1
40	53.0090	.RIM, 8 X 8.5, 5 ON 4.5 BC	1
41	53.0089	.TIRE, FIELD 22 X 12 X 8-NO RIM	1
42	53.0139	.VALVE STEM	2
43	00.0348	.DECAL, WARNING HUB SIDE (Serial # 01001-14497)	1
43	00.0645	.DECAL, HUB SIDE (Serial # 14498-)	1
45	53.0090	.RIM, 8 X 8.5, 5 ON 4.5 BC	1
46	53.0114	.TIRE, BAR 21X11X8 NO RIM	1
47	53.0139	.VALVE STEM	2
48	00.0348	.DECAL, WARNING HUB SIDE (Serial # 01001-14497)	1
48	00.0645	.DECAL, HUB SIDE (Serial # 14498-)	1
49	53.0090	.RIM, 8 X 8.5, 5 ON 4.5 BC	1
50	53.0114	.TIRE, BAR 21X11X8 NO RIM	1
51	53.0139	.VALVE STEM	2
52	00.0348	.DECAL, WARNING HUB SIDE (Serial # 01001-14497)	1
52	00.0645	.DECAL, HUB SIDE (Serial # 14498-)	1
55	53.0138	.RIM, 10 X 7 - 5 ON 4.5 BC	1
56	53.0112	.TIRE, TURFMASTR 22X11X10 NO RIM	1
57	53.0139	.VALVE STEM	2
58	00.0348	.DECAL, WARNING HUB SIDE (Serial # 01001-14497)	1
58	00.0645	.DECAL, HUB SIDE (Serial # 14498-)	1
60	53.0142	.TUBE, INNER 22 X 12 X 8	4

HYDRAULICS, AXLES, & WHEELS

Model 2600 Transaxle (51.0020/51.0087)

REF.	PART NO.	DESCRIPTION	QTY.
1	51.0026	.COVER, 2600 TRANSAXLE (Includes 2A & 2B)* (Serial # 01001-12728)	1
1	51.0088	.COVER, 2600 TRANSAXLE (Includes 2A & 2B)* (Serial # 12729-)	1
2	55.0037	.BEARING, 2600 NEEDLE 1.000 ID	1
2A	55.0038	.BEARING, 2600 NEEDLE 1.000 ID	3
2B	55.0041	.BEARING, 2600 NEEDLE 1.250 ID	2
3	51.0025	.CASE, 2600 TRANSAXLE (Serial # 01001-12728)	1
3	51.0089	.CASE, 2600 TRANSAXLE (Serial # 12729-)	1
5	51.0093	.SHAFT, OUTPUT	1
10A	51.0030	.FORK, 2600 SHIFT	1
13	51.0031	.GEAR, 2600 BEVEL	1
13A	51.0031	.GEAR, 2600 BEVEL	1
14	51.0033	.PINION, 2600 BEVEL	2
24	51.0085	.BEARING, THRUST 1.002 ID X .0781W	1
29	51.0084	.WASHER, THRUST 1.002 ID X .061W	2
29B	51.0032	.WASHER, 2600 THRUST	3
31	51.0082	.WASHER, THRUST 1.252 ID X .058W	2
31A	51.0028	.WASHER, 2600 THRUST	2
39	51.0029	.PIN, DOWEL 2600 5/16 X 3/4	2
85A	29.P06H	.PIPE, PLUG 3/8 HEX ZP (Serial # 01001-12728)	1
85A	25.6408-H-06	.FITTING, -06 MB X HOLLOW ALLEN (Serial # 12729-)	1
85B	29.P02-1	.PIPE, PLUG 1/8 HEX SOCKET ZP (Serial # 01001-12728)	1
85B	25.6408-H-06	.FITTING, -06 MB X HOLLOW ALLEN (Serial # 12729-)	1
87	89.0046	.SEAL, BRAKE SHAFT OIL	1
87A	89.0047	.SEAL, SHIFTER ROD OIL	1
89	55.0039	.BEARING, 2600 NEEDLE 1.5743 ID	1
124	89.0051	.GASKET, CASE	1
149	51.0027	.ROD, 2600 SHIFT (HIGH/LOW)	1
157	89.0049	.SEAL, OIL - AXLE PEERLESS	2

Listed items are stocked. Check for availability of unlisted parts.

*Ref. 2 brake shaft bearing must be ordered separately.

HYDRAULICS, AXLES, & WHEELS

ILLUSTRATED DRAWING Model 15 Hydraulic Motor (21.0081)

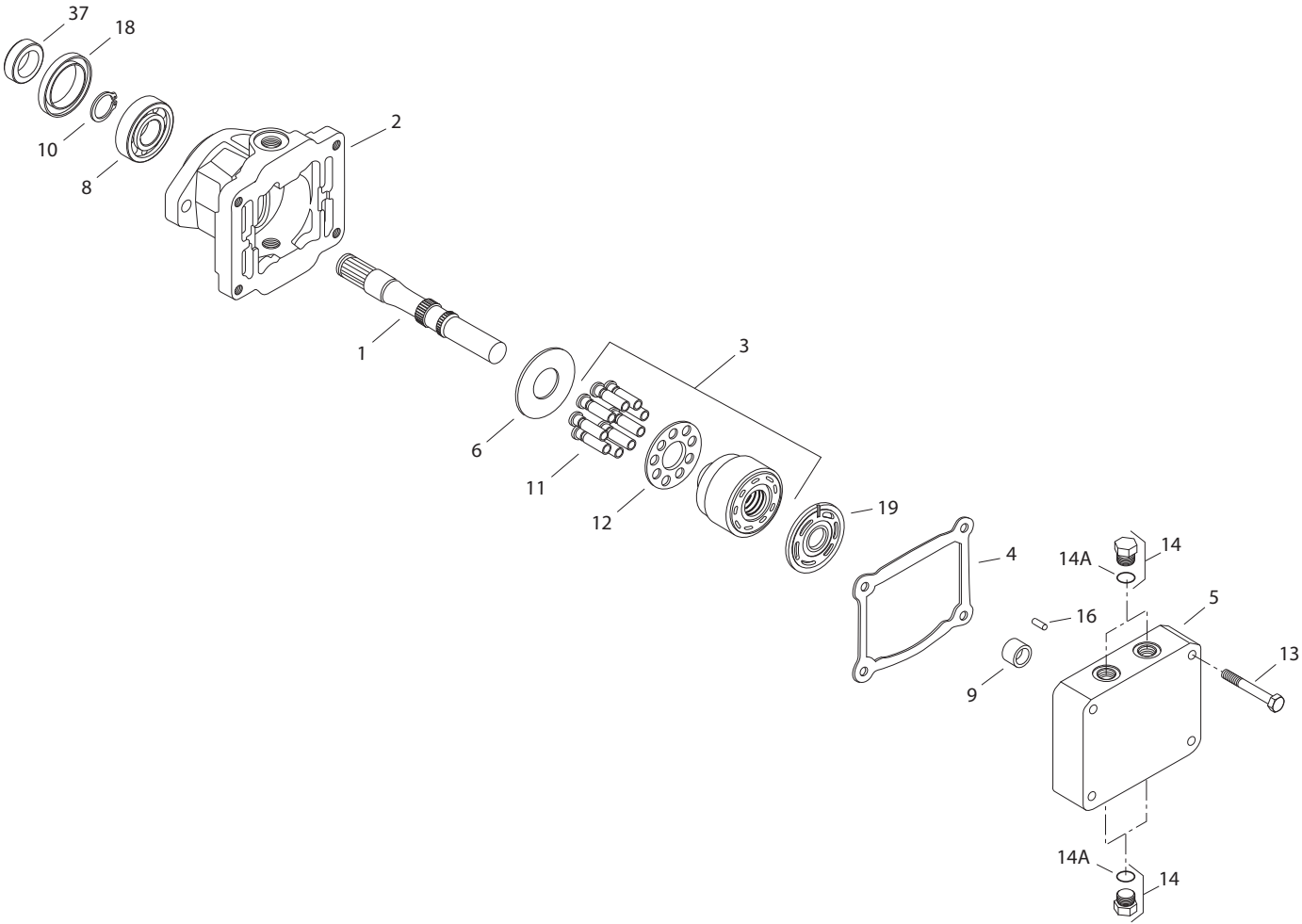

HYDRAULICS, AXLES, & WHEELS

Model 15 Hydraulic Motor (21.0081)

REF.	PART NO.	DESCRIPTION	QTY.
3	21.0099	.KIT, CYL BLOCK SUNDSTRAND	1
4	89.0055	.GASKET, MOTOR 2 BOLT FLANGE	1
6	21.0019	.PLATE, THRUST SUNDSTRAND	1
8	55.0031	.BEARING, BALL-1500 SERIES SUND	1
9	55.0036	.BEARING, DU SUNDSTRAND	1
11	21.0099-1	.PISTON, CYLINDER BLOCK	9
12	21.0099-2	.RETAINER, PISTON CYLINDER BLCK	1
14	25.6408-08	.FITTING, PLUG 8MB	4
14a	26.0037	.O-RING, -908 FOR MORB-08 VITON	4
18	89.0062	.SEAL, SHAFT-SERIES 15 MOTOR	1
19	21.0088	.PLATE, VALVE (MOTOR)	1

Listed items are stocked. Check for availability of unlisted parts.

HYDRAULICS, AXLES, & WHEELS

ILLUSTRATED DRAWING Model 15 Hydraulic Pump (21.0080)

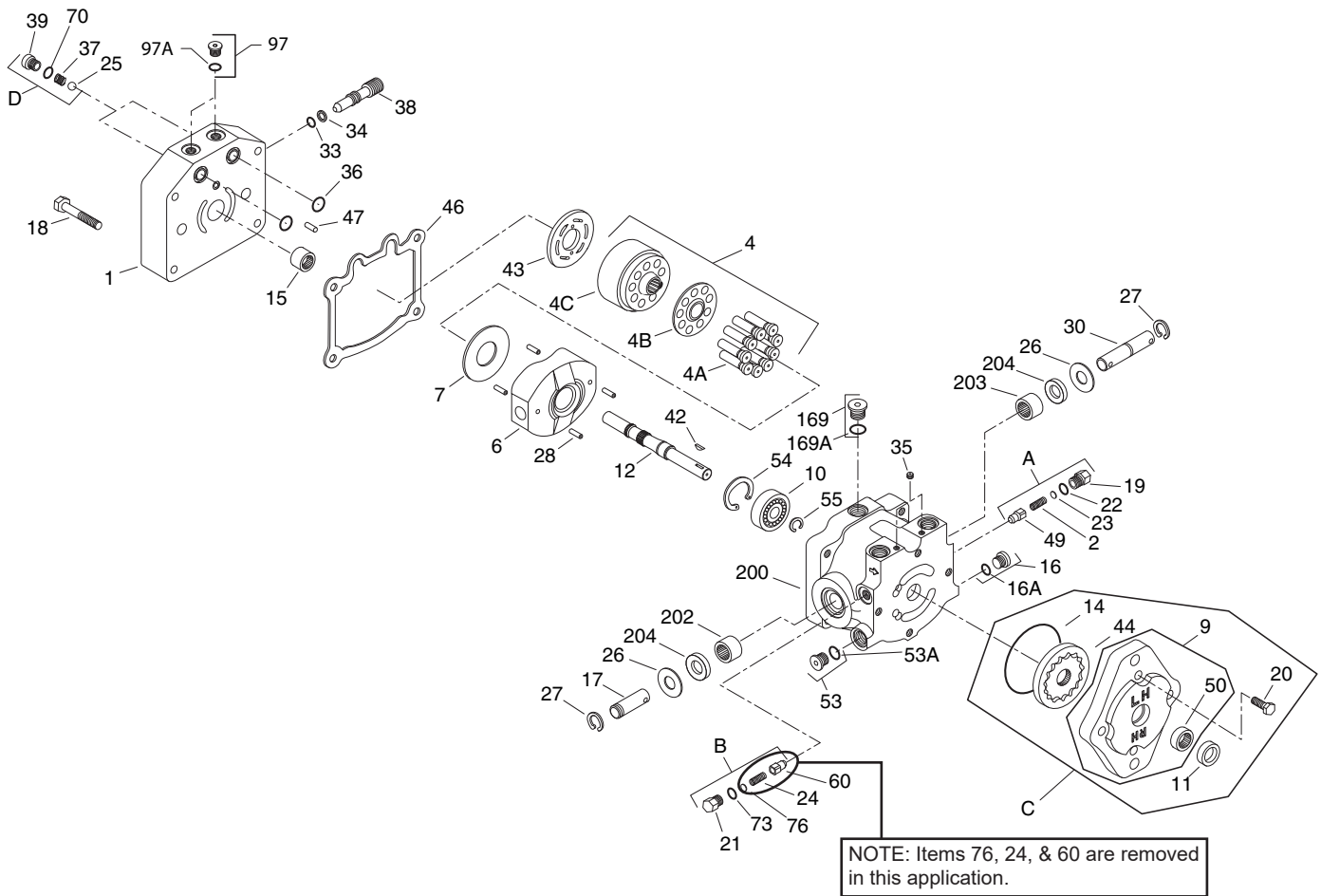

Note: Item 200 includes items 202, 203 and 204

HYDRAULICS, AXLES, & WHEELS

Model 15 Hydraulic Pump (21.0080)

REF.	PART NO.	DESCRIPTION	QTY.
1	NOT STOCKED	CAP, END	3
2	21.0087	SPRING, IMPLEMENT RELIEF	1
4	21.0099	KIT, CYL BLOCK SUNDSTRAND	1
4A	21.0099-1	PISTON, CYLINDER BLOCK	9
4B	21.0099-2	RETAINER, PISTON CYLINDER BLCK	1
4C	NOT STOCKED	BLOCK, CYLINDER	1
6	21.0101	SWASHPLATE, SUNDSTRAND	1
7	21.0019	PLATE, THRUST SUNDSTRAND	1
9	21.0032	HOUSING, CHARGE PUMP (PUMP SERIAL # A063910905 OR EARLIER)	1
9	21.0033	HOUSING, CHARGE PUMP (PUMP SERIAL # A063910906-)	1
10	55.0034	BEARING, BALL SUNDSTRAND	1
11	89.0052-1	SEAL, 3/4 SFT X 1 1/4 VITON	1
12	21.0028	SHAFT, PUMP 15 PV	1
14	26.0008	O-RING, 0.103 X 3.487ID X 3.693OD VITON	1
15	55.0025	BEARING, ROLLER .6875 X .937	1
16	NOT STOCKED	PLUG	1
16A	26.0038	O-RING, -910 FOR MORB-10 VITON	1
17	21.0076	SHAFT, TRUNNION SUNDSTRAND	1
18	NOT STOCKED	SCREW	4
19	21.0089	PLUG, RELIEF VALVE SUNDSTRAND	1
20	NOT STOCKED	SCREW	4
21	NOT STOCKED	PLUG	1
22	26.0013	O-RING, -905 FOR MORB-05 VITON	1
23	21.0093	SHIM, .020 X 5/16 OD, HI-PRESS	1
23	21.0094	SHIM, .010 X 5/16 OD, HI-PRESS	1
23	21.0106	SHIM, .005 X 5/16 OD, HI-PRESS	1
24	41.0091	SPRING, COMP 1/4"OD X 1" LG	1
25	NOT STOCKED	BALL	2
26	21.0049	WASHER, .699 X 1.375 X .059	2
27	04.0014	SNAP RING, EXT. 11/16 SFT	2
28	02.CP0605C	ROLL PIN, 3/16 X 5/8 COILED	4
30	21.0075	SHAFT, TRUNNION-CTRL-SERIES 15	1
33	26.0025	O-RING, -.012 FOR MORF-06 VITON	1
34	04.0039	RING, BACK UP	1
35	NOT STOCKED	PLUG, PIPE	2
36	26.0009	O-RING, .070 X .489 ID 90D	2
37	NOT STOCKED	SPRING	2
38	23.0165	VALVE, BYPASS	1
39	NOT STOCKED	PLUG	2
42	85.W0305	KEY, WOODRUFF 3/16" X 5/8"	1
43	21.0026	PLATE, VALVE (LH) PUMP	1
44	21.0027	GEROTOR, ASM PUMP	1
46	89.0054	GASKET, PUMP SUNDSTR.SERIES 15	1
47	NOT STOCKED	PIN	1
49	NOT STOCKED	CONE, CHARGE RELIEF	1
50	55.0024	BEARING, NEEDLE 3/4X1 SERIES15	1
53	NOT STOCKED	PLUG	1
53A	26.0038	O-RING, -910 FOR MORB-10 VITON	1
54	NOT STOCKED	RING, RETAINING	1
55	NOT STOCKED	RING, RETAINING	1
60	NOT STOCKED	CONE, CHARGE RELIEF	1
70	26.0013	O-RING, -905 FOR MORB-05 VITON	2
73	26.0013	O-RING, -905 FOR MORB-05 VITON	1
76	21.0093	SHIM, .020 X 5/16 OD, HI-PRESS	1
76	21.0094	SHIM, .010 X 5/16 OD, HI-PRESS	1
76	21.0106	SHIM, .005 X 5/16 OD, HI-PRESS	1
97	NOT STOCKED	PLUG	2
97A	26.0035	O-RING, -904 FOR MORB-04 VITON	2
169	NOT STOCKED	PLUG	1
169A	26.0037	O-RING, -908 FOR MORB-08 VITON	1
200	NOT STOCKED	ASSEMBLY, HOUSING	1
202	85.B0067	BUSHING, BEARING JOURNAL	1
203	85.B0067	BUSHING, BEARING JOURNAL	1
204	89.0053-1	SEAL, .687 SFT X 1.19 VITON	2
A	NOT STOCKED	KIT, IMPLEMENT RELIEF	1
B	NOT STOCKED	KIT, CHARGE RELIEF	1
C	NOT STOCKED	KIT, CHARGE PUMP	1
D	NOT STOCKED	KIT, CHECK VALVE	1

ENGINES

ILLUSTRATED DRAWING 4500P Kawasaki Engine

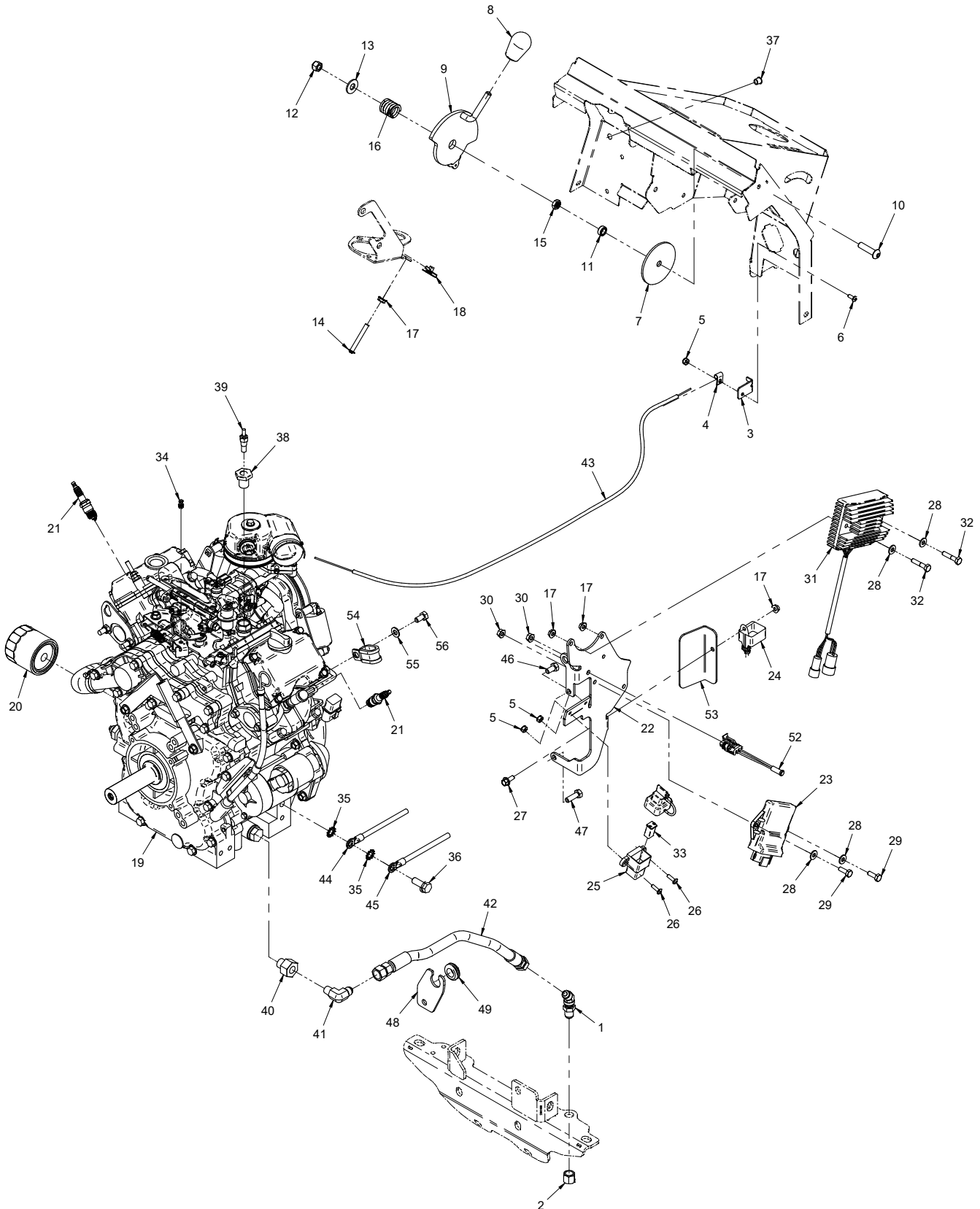

ENGINES

4500P Kawasaki Engine

REF.	PART NO.	DESCRIPTION	QTY.
1	25.2702-06-06LN	.FITTING, BULKHEAD 3/8 W/LN 45	1
2	25.304-C-06	.FITTING, CAP 3/8 #6 JIC	1
3	64.1700	.BRACKET, CABLE END	1
4	45.0050	.CLAMP, CABLE	1
5	99.A1032N	.LOCKNUT, NYLON 10-32 STAINLESS	3
6	99.K0062	.MACHINE SCREW, #10-32 X 1/2	1
7	05.0013	.WASHER, FRIC. 3 OD X 13/32 ID	1
8	47.0001	.KNOB, SM. #80 3/8-16 THREAD	1
9	40.0377	.LEVER, THROTTLE	1
10	99.0614	.BOLT, 3/8-16 X 1-3/4 BSCS	1
11	64.0602	.BUSHING, 3/8 X 5/8 X .265	1
12	99.A06N	.LOCKNUT, NYLON 3/8-16 USS	1
13	94.06	.WASHER, FLAT 3/8 USS	1
14	99.0416	.BOLT, 1/4-20 X 2 BSCS	1
15	99.E0113	.NUT, JAM 3/8-16 NYLON LOCK GR8	1
16	41.0107	.SPRING, COMP. .970" OD X 1" LG	1
17	99.SF04	.NUT, SRF 1/4-20 USS	3
18	99.E0046	.NUT, "U" 1/4-20 EXTRUDED	1
19	13.0244	.ENGINE, KAWASAKI 31 HP GAS LC	1
20	13.0268	.FILTER, ENGINE OIL KAWASAKI	1
21	13.0284	.PLUG, SPARK NGK BPR4ES	2
22	64.1647	.BRACKET, CDI, R&R MOUNT (Serial # 01001-03821)	1
22	64.1900	.BRACKET, CDI, R&R MOUNT (Serial # 03822-)	1
23	13.211752065	.ENGINE CONTROL UNIT (ECU)	1
24	13.0302	.RELAY ASSEMBLY, KAWASAKI	1
25	30.0402	.FUSE HOLDER, 50A J CASE	1
26	99.K0071	.MACHINE SCREW, #10-32 X 5/8	2
27	99.SF0405-1	.BOLT, SMF 1/4-20 X 5/8	1
28	95.04	.WASHER, FLAT 1/4 SAE	4
29	90.0406	.BOLT, 1/4-20 USS X 3/4	2
30	99.E0101	.NUT, LOCKING FLANGE 1/4-20	2
31	13.0288	.REGULATOR, 30 AMP KAWASAKI	1
32	90.0410	.BOLT, 1/4-20 USS X 1/1-4"	2
33	30.0373	.FUSE, 40A J-CASE GREEN	1
34	47.0234	.THROTTLE CONTROL, WIRE SWIVEL	1
35	99.G0004	.WASHER, STAR-EXTERNAL 3/8	2
36	99.M0020	.BOLT, M10 X 1.5 X 25MM FLANGE	1
37	05.0087	.PLUG, 3/8" HOLE, BLACK	1
38	14.0049	.ADAPTER, M16-1.5 X 1/8 FP (Serial # 01001-02476)	1
38	14.0052	.ADAPTER, M16-1.5 X 1/8 FNPT (Serial # 02477-15488)	1
38	14.0049	.ADAPTER, M16-1.5 X 1/8 FP (Serial # 15489-)	1
39	13.0286	.SENDING UNIT, TEMPERATURE (Serial # 01001-02476)	1
39	13.0309	.SENDING UNIT, TEMPERATURE (Serial # 02477-15488)	1
39	13.0286	.SENDING UNIT, TEMPERATURE (Serial # 15489-)	1
40	14.0015	.FITTING, ADAPTER 1/4 X M16	1
41	25.2501-06-04	.FITTING, 90 ME 3/8 X 1/4	1
42	22.0060	.HOSE, 3/8X15.50 PLK 250 PSI CPE	1
43	47.0322	.CABLE, THROTTLE KN	1
44	32.0103	.CABLE, ASM NEG 4GA	1
45	32.0112	.CABLE, ASM NEG 4GA	1
46	99.M0014	.BOLT, M8 X 1.25 X 16MM	1
47	99.M0009	.BOLT, M8 X 1.25 P X 25MM LONG	1
48	64.1728	.BRACKET, OIL DRAIN HOSE	1
49	05.0140	.GROMMET, 5/8 ID, 1-1/8 OD, 3/8T	1
52	33.0063-1	.LIGHT, LED SUPER YELLOW (Serial # 02860-)	1
53	60.1266	.SHIELD, WIRE PROTECTION (Serial # 03822-)	1
54	11.0046	.CLAMP, CUSHIONED 1/2" 2-TUBE (Serial # 06269-)	1
55	95.05	.WASHER, FLAT 5/16 SAE (Serial # 06269-)	1
56	99.M0014	.BOLT, M8 X 1.25 X 16MM (Serial # 06269-)	1

ENGINES

ILLUSTRATED DRAWING 4500P Kawasaki Engine Mount

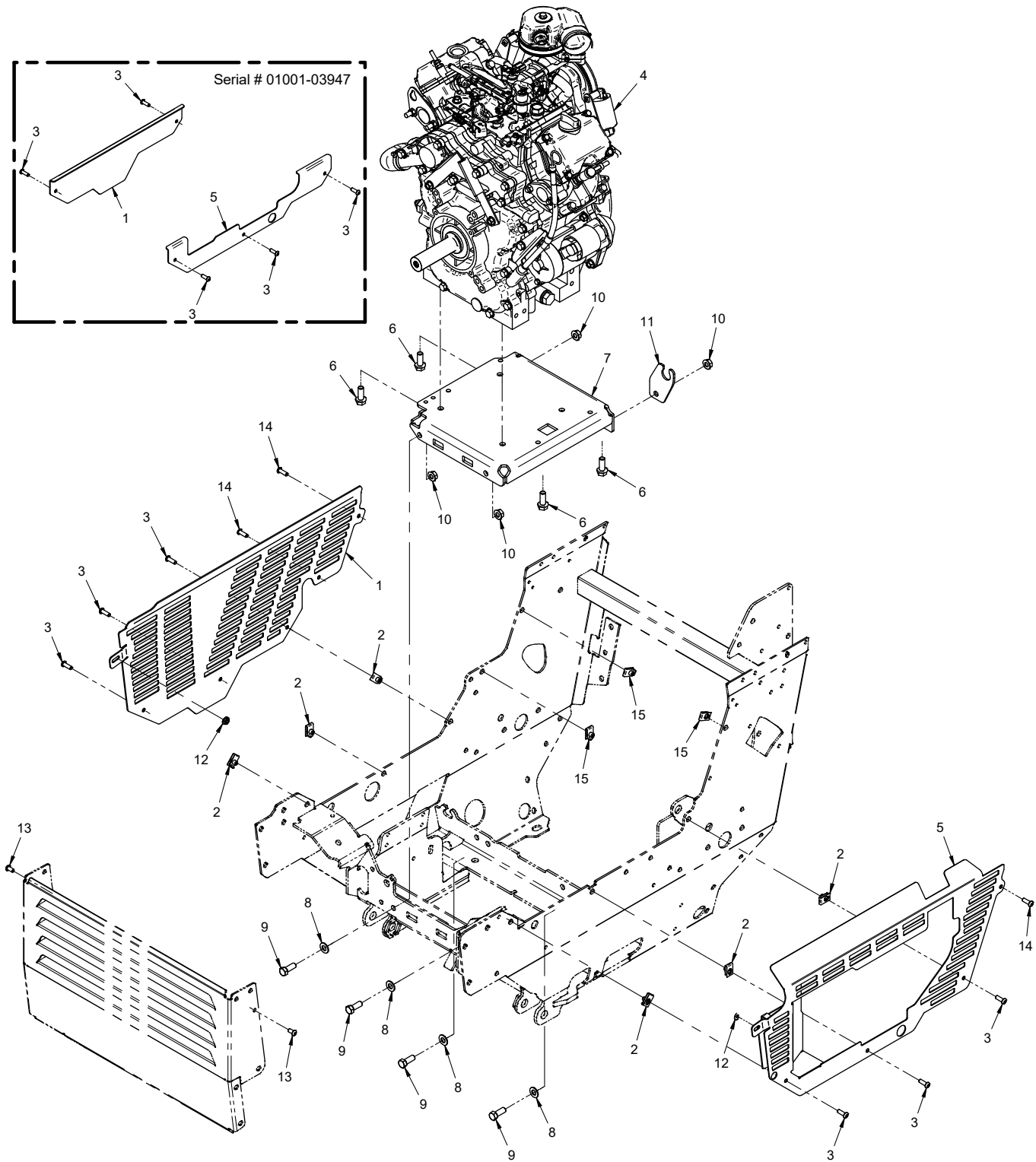

ENGINES

4500P Kawasaki Engine Mount

REF.	PART NO.	DESCRIPTION	QTY.
1	60.1137	.PANEL, ENGINE ACCESS RIGHT (Serial # 01001-03947)	1
1	60.1208	.COVER, ENGINE RIGHT 4500 (Serial # 03948-)	1
2	99.E0046	.NUT, "U" 1/4-20 EXTRUDED	6
3	99.0406	.BOLT, 1/4-20 X 3/4 BSCS	6
4	13.0244	.ENGINE, KAWASAKI 31 HP GAS LC	1
5	60.1138	.PANEL, ENGINE ACCESS LEFT (Serial # 01001-03947)	1
5	60.1210	.COVER, ENGINE LEFT 4500P (Serial # 03948-)	1
6	99.M0020	.BOLT, M10 X 1.5 X 25MM FLANGE	4
7	64.1632	.MOUNT, ENGINE 2 CYL	1
8	95.06	.WASHER, FLAT 3/8 SAE	4
9	90.0608	.BOLT, 3/8-16 USS X 1	4
10	99.SF06	.NUT, SRF 3/8-16 USS	4
11	64.1728	.BRACKET, OIL DRAIN HOSE	1
12	99.SF04	.NUT, SRF 1/4-20 USS	2
13	99.0404	.BOLT, 1/4-20 X 1/2 BSCS	2
14	99.0404	.BOLT, 1/4-20 X 1/2 BSCS (Serial # 01001-03966)	3
14	99.0406	.BOLT, 1/4-20 X 3/4 BSCS (Serial # 03967-)	3
15	99.SF04	.NUT, SRF 1/4-20 USS (Serial # 01001-03966)	3
15	99.E0046	.NUT, "U" 1/4-20 EXTRUDED (Serial # 03967-)	3

ENGINES

ILLUSTRATED DRAWING 4500P Kawasaki PTO Clutch

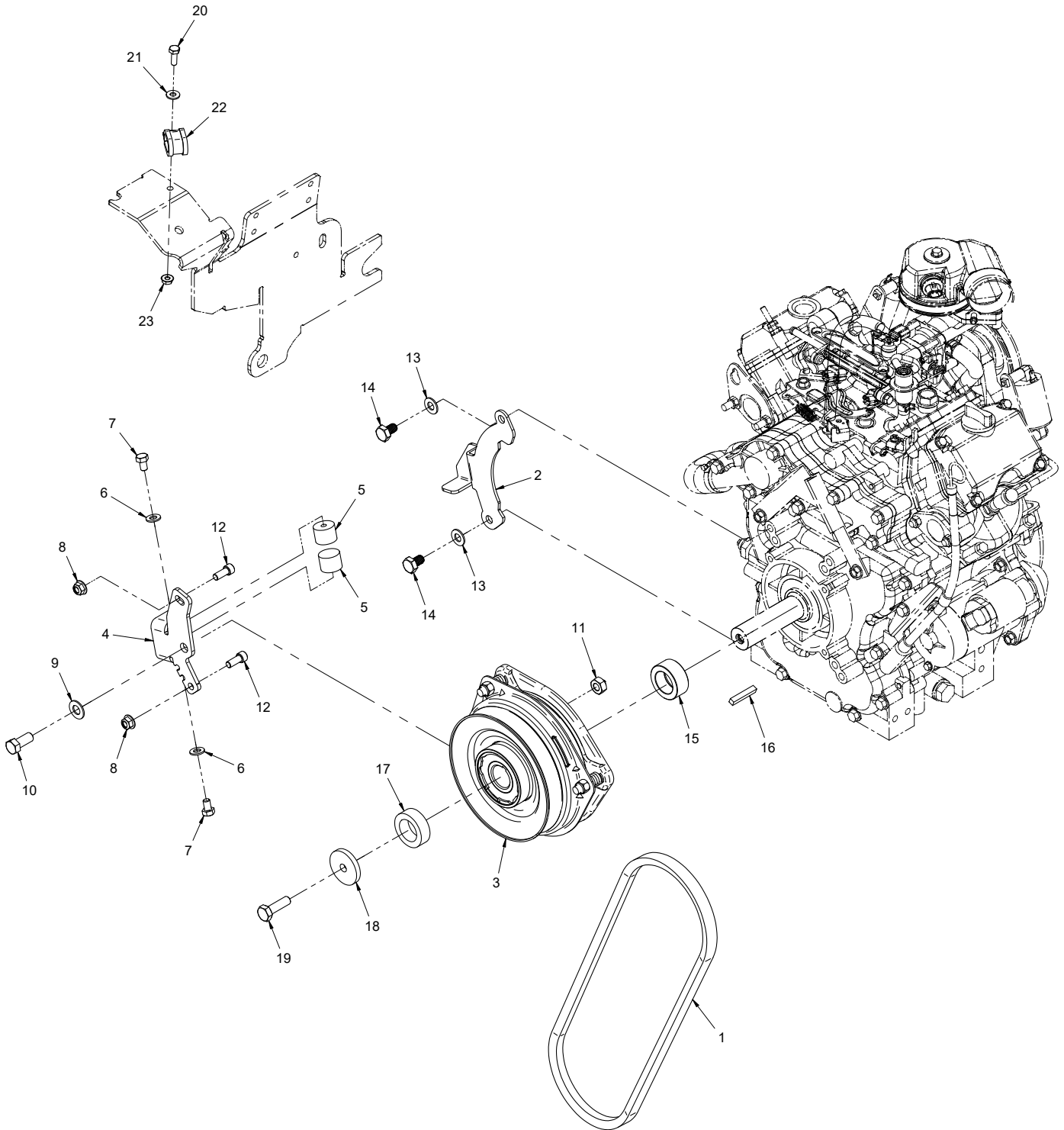

ENGINES

4500P Kawasaki PTO Clutch

REF.	PART NO.	DESCRIPTION	QTY.
1	81.B038	.BELT, B38	1
2	64.1696	.BRACKET, CLUTCH STOP	1
3	37.0060	.CLUTCH, ELECTRIC OGURA GT3.5	1
4	64.1698	.BRACKET, CLUTCH TORQUE	1
5	05.0110	.BUMPER, RUBBER 1" DIA	2
6	95.05	.WASHER, FLAT 5/16 SAE	2
7	90.0504	.BOLT, 5/16-18 USS X 1/2"	2
8	99.E0102	.NUT, LOCKING FLANGE 5/16-18	2
9	95.07	.WASHER, FLAT 7/16 SAE	1
10	90.0708	.BOLT, 7/16-14 USS X 1	1
11	99.A07	.LOCKNUT, STOVER 7/16-14 USS	1
12	99.K0134	.BOLT, SHCS 5/16-18 X 3/4	2
13	95.06	.WASHER, FLAT 3/8 SAE	2
14	99.M0012	.BOLT, M10 X 1.5 X 25MM	2
15	64.1172	.SPACER, INNER CLUTCH	1
16	85.K0412	.KEY, 1/4 X 1-1/2	1
17	64.1079	.BUSHING, CLUTCH SPACER - OUTER	1
18	99.B0065	.WASHER, 1/4 X 1.75 X .406 HOLE	1
19	99.M0017	.BOLT, M10 X 1.5 X 35 MM	1
20	90.0406	.BOLT, 1/4-20 USS X 3/4	1
21	95.04	.WASHER, FLAT 1/4 SAE	1
22	11.0046	.CLAMP, CUSHIONED 1/2" 2-TUBE	1
23	99.SF04	.NUT, SRF 1/4-20 USS	1

ENGINES

ILLUSTRATED DRAWING 4500P Kawasaki Drive Shaft & Pump

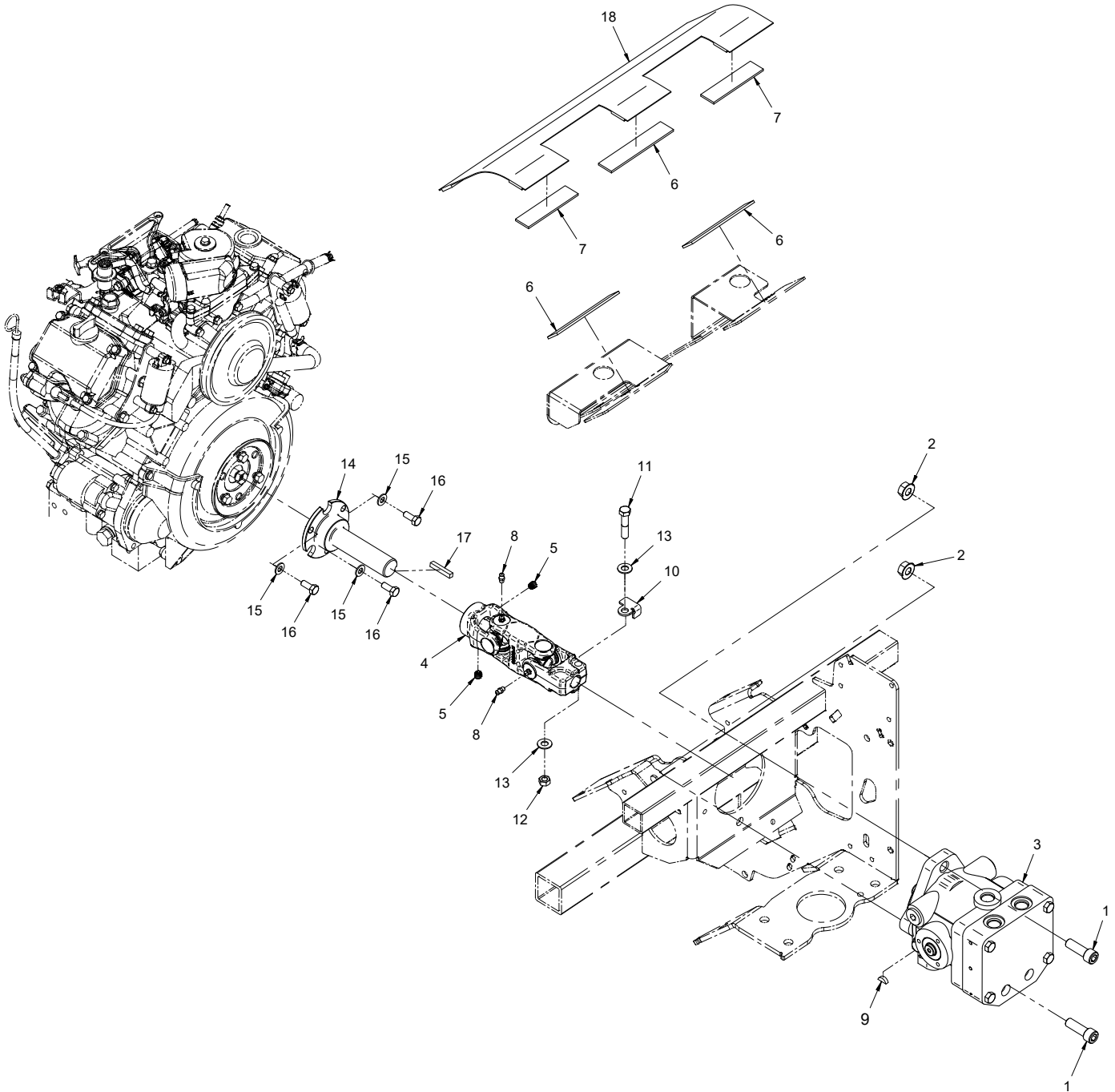

ENGINES

4500P Kawasaki Drive Shaft & Pump

REF.	PART NO.	DESCRIPTION	QTY.
1	99.K0039	.BOLT, SHCS 1/2 X 1 1/2	2
2	99.SF08	.NUT, SRF 1/2-13 USS	2
3	21.0080	.PUMP, HYD. CCW 1000 PSI	1
4	87.0232	.U-JOINT, 4500	1
5	85.SS21	.SET SCREW, 3/8-16 X 3/8	2
6	06.0065-5IN	.VELCRO, LOOP 1" BLACK X 5"	3
7	06.0065-4IN	.VELCRO, LOOP 1" BLACK X 4"	2
8	29.GF0001	.GREASE FTG, 1/4 SAE ST	2
9	85.W0305	.KEY, WOODRUFF 3/16" X 5/8"	1
10	64.1654	.PLATE, DRIVESHAFT TACH TRIGGER	1
11	90.0614	.BOLT, 3/8-16 USS X 1-3/4	1
12	99.A06	.LOCKNUT, STOVER 3/8-16 USS	1
13	95.06	.WASHER, FLAT 3/8 SAE	2
14	13.0259	.STUB SHAFT, PUMP DRIVE KAW	1
15	95.05	.WASHER, FLAT 5/16 SAE	3
16	99.M0005	.BOLT, M8 X 1.25 P X 20MM LONG	3
17	85.K0412	.KEY, 1/4 X 1-1/2	1
18	44.0322	.CANVAS, DEBRIS BARRIER	1

ENGINES

ILLUSTRATED DRAWING 4500P Kawasaki Muffler

Serial # 03403 - 08787

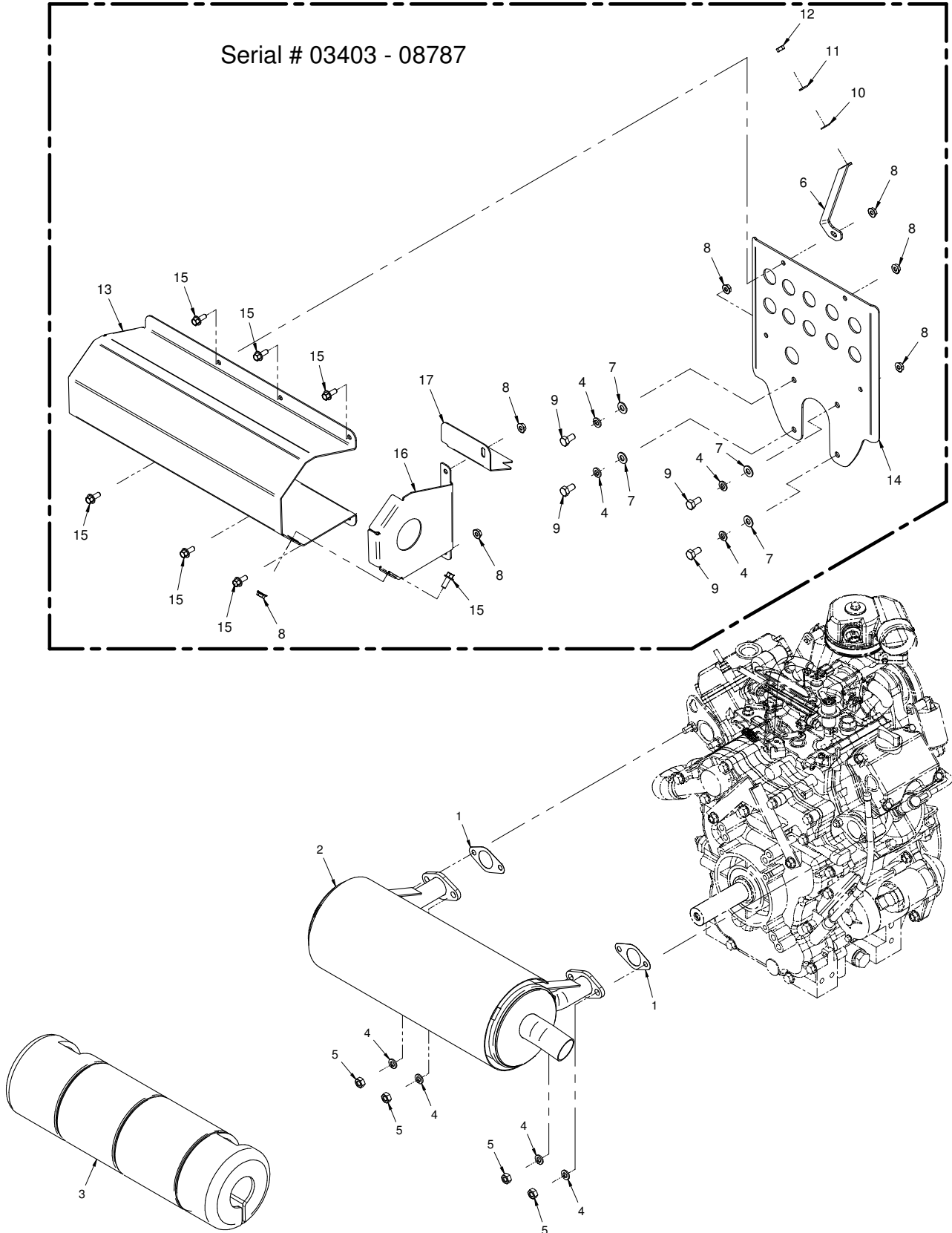

ENGINES

4500P Kawasaki Muffler

REF.	PART NO.	DESCRIPTION	QTY.
1	13.0197	.GASKET, EXHAUST KAWASAKI	2
2	13.0245	.MUFFLER, KAWASAKI 31 HP GAS (Serial # 01001-08787)	1
2	13.0314	.MUFFLER, KAWASAKI FD851D (Serial # 08788-)	1
3	44.0317	.INSULATION, MUFFLER 13.0245 (Serial # 01001-03402)	1
4	96.05	.WASHER, LOCK 5/16	8
5	99.M0008	.NUT, M8 X 1.25MM ZP	4
6	64.1858	.BRACE, MUFFLER HEAT 4500P (Serial # 03403-08787)	1
7	95.05	.WASHER, FLAT 5/16 SAE (Serial # 03403-08787)	4
8	99.SF04	.NUT, SRF 1/4-20 USS (Serial # 03403-08787)	7
9	99.M0014	.BOLT, M8 X 1.25 X 16MM (Serial # 03403-08787)	4
10	99.B0051	.WASHER, FLAT #10 (Serial # 03403-08787)	1
11	96.04	.WASHER, LOCK 1/4 (Serial # 03403-08787)	1
12	99.M0031	.NUT, M6 X 1.0MM (Serial # 03403-)	1
13	60.1255-1	.SHIELD, MUFFLER HEAT 4500P (Serial # 03403-08787)	1
14	64.1859	.MOUNT, MUFFLER HEAT 4500P (Serial # 03403-08787)	1
15	99.SF0405-1	.BOLT, SMF 1/4-20 X 5/8 (Serial # 03403-08787)	7
16	60.1264	.SHIELD, END HEAT MUFFLER (Serial # 03403-08787)	1
17	60.1303-1	.SHIELD, MUFFLER HEAT (Serial # 05606-08787)	1

ENGINES

ILLUSTRATED DRAWING 4500P Kawasaki Cooling System

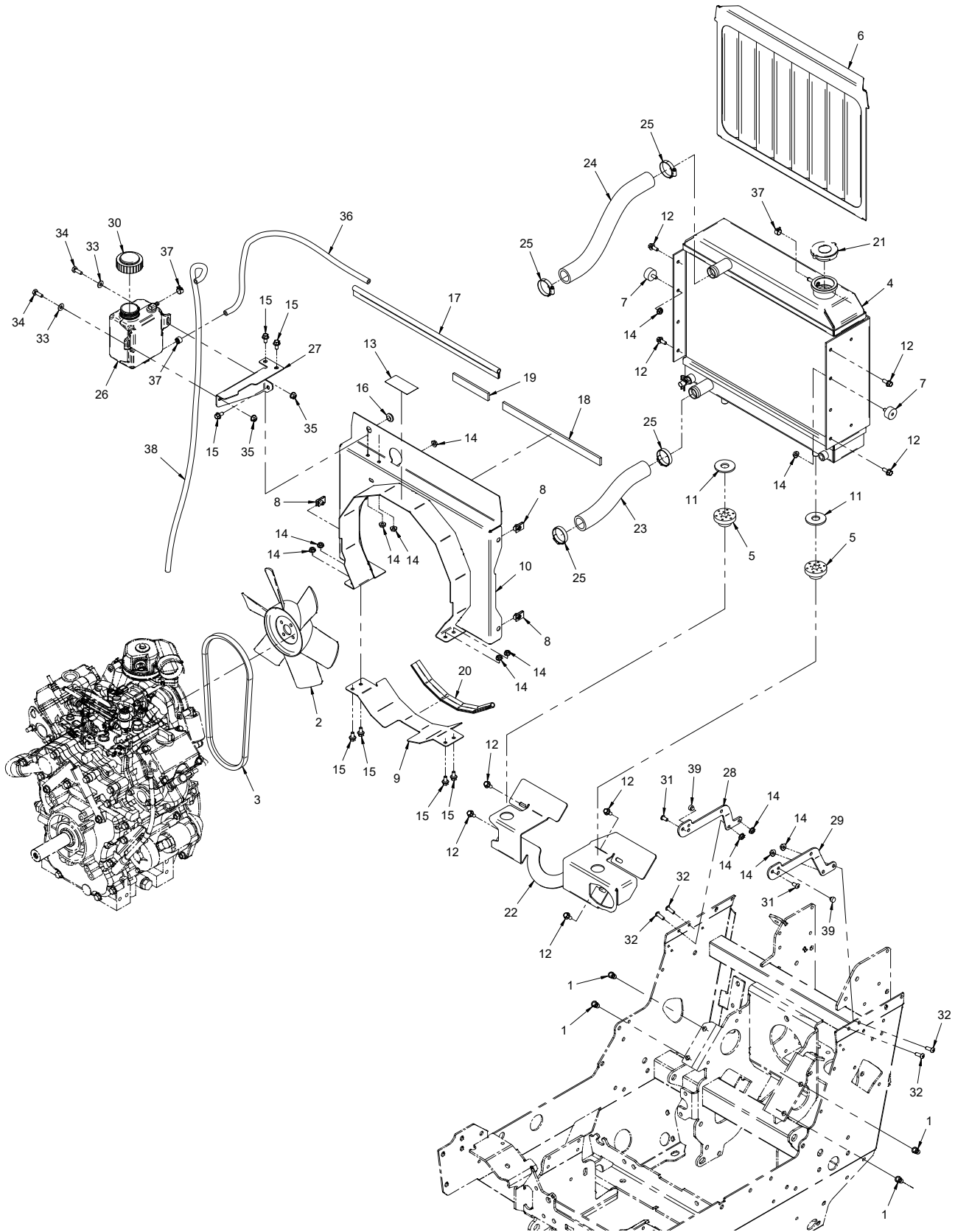

ENGINES

4500P Kawasaki Cooling System

REF.	PART NO.	DESCRIPTION	QTY.
1	99.E0105	.NUT, INSERT 1/4-20 HEX	4
2	13.0189	.FAN, KAWASAKI 11"	1
3	81.0132	.BELT, FAN KAWASAKI	1
4	47.0321	.RADIATOR, KN KAWASAKI	1
5	05.0107	.ISOLATOR, 9/16 ID X 1-29/32 OD	2
6	64.1620	.SCREEN, RADIATOR - 47.0302	2
7	05.0135	.ISOLATOR, 1/4-20 X 1/2 X 1" F/M	2
8	99.E0046	.NUT, "U" 1/4-20 EXTRUDED	4
9	64.1644	.BRACKET, RADIATOR SHROUD	1
10	60.1155	.SHROUD, RADIATOR - 47.0321	1
11	94.10	.WASHER, FLAT 5/8 USS	2
12	99.SF0405-1	.BOLT, SMF 1/4-20 X 5/8	8
13	00.0341	.DECAL, WARNING FAN (Serial # 01001-14497)	1
13	00.0638	.DECAL, FAN BLADE HAZARD (Serial # 14498-)	1
14	99.SF04	.NUT, SRF 1/4-20 USS	13
15	99.SF0404-1	.BOLT, SMF 1/4-20 X 1/2	7
16	05.0136	.GROMMET, 7/16ID, 3/4OD, 1/4THK	1
17	06.0043-17.5IN	.TRIM, TRIM SEAL W/ BULB X 17-1/2"	1
18	06.0045-11.75IN	.WEATHERSTRIP, 1/8 X 3/4 X 11-3/4"	1
19	06.0045-4.25IN	.WEATHERSTRIP, 1/8 X 3/4 X 4-1/4"	1
20	06.0043-10IN	.TRIM, TRIM SEAL W/ BULB X 10"	1
21	47.0334	.CAP, RADIATOR 14#	1
22	64.1704	.BRACKET, RADIATOR MOUNT BOTTOM	1
23	13.0261	.HOSE, RADIATOR LOWER KAW	1
24	13.0260	.HOSE, RADIATOR UPPER KAW	1
25	11.0052	.CLAMP, HOSE SS 13/16 X 1-1/2	4
26	47.0317	.TANK, COOLANT RECOVER	1
27	64.1640	.BRACKET, COOLANT RECOVERY TANK	1
28	64.1629	.BRACKET, RADIATOR MOUNT RIGHT	1
29	64.1642	.BRACKET, RADIATOR MOUNT LEFT	1
30	47.0319	.CAP, COOLANT RECOVERY TANK	1
31	99.0404	.BOLT, 1/4-20 X 1/2 BSCS	2
32	99.0406	.BOLT, 1/4-20 X 3/4 BSCS	4
33	95.04	.WASHER, FLAT 1/4 SAE	2
34	90.0406	.BOLT, 1/4-20 USS X 3/4"	2
35	99.E0101	.NUT, LOCKING FLANGE 1/4-20	2
36	27.A04-21IN	.HOSE, NEOP BLACK 1/4 X 7/16 X 21"	1
37	11.0049	.CLAMP, HOSEBAND 1/4X1/2 HOSE	3
38	27.A04-36IN	.HOSE, NEOP BLACK 1/4 X 7/16 X 36"	1
39	05.0120	.BUMPER, NEOPRENE 10 GA - 1/4 (Serial # 01323 -)	2

ENGINES

ILLUSTRATED DRAWING 4500P Kawasaki Air Intake

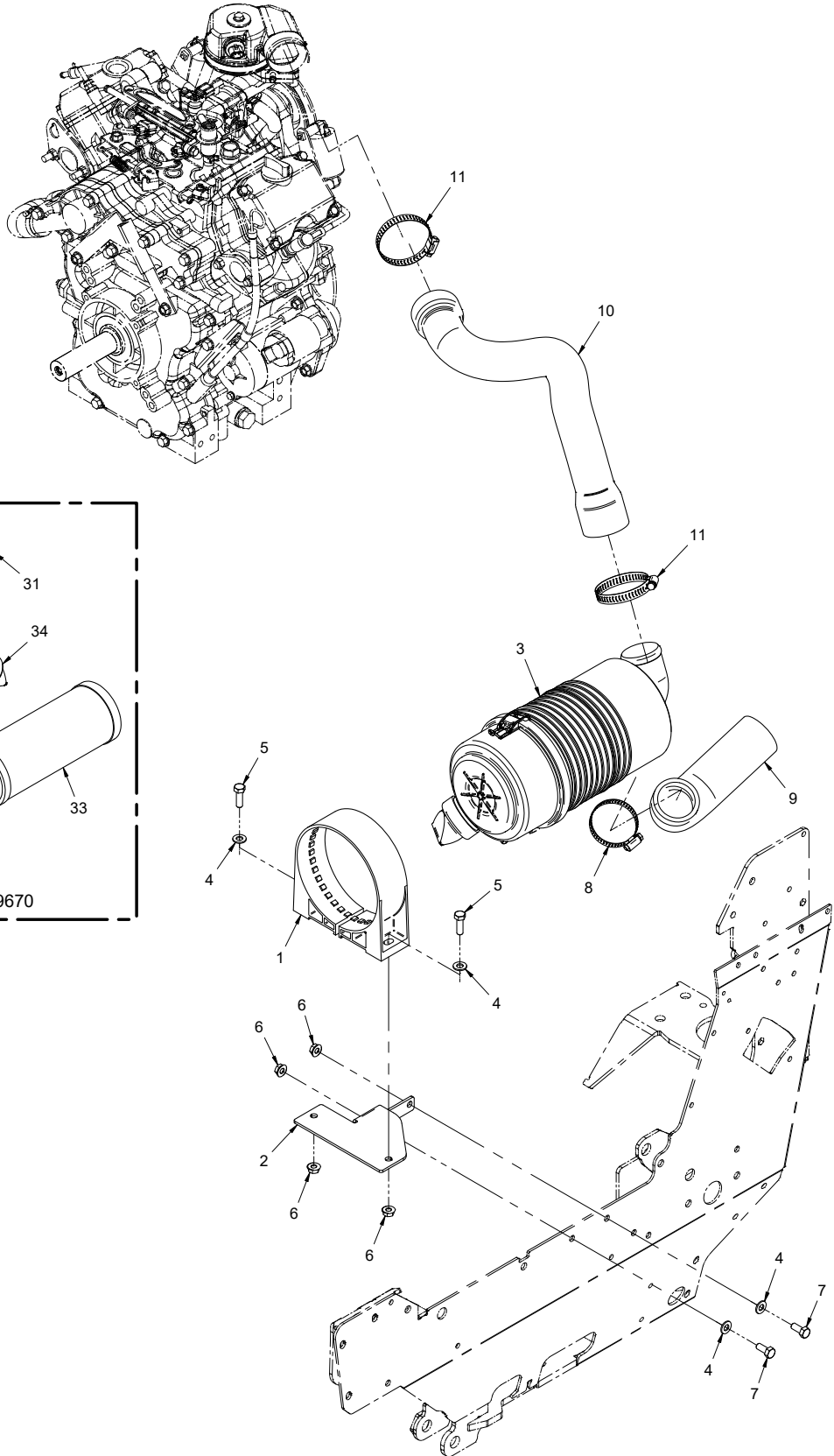

ENGINES

4500P Kawasaki Air Intake

REF.	PART NO.	DESCRIPTION	QTY.
1	13.0231	.CLAMP, AIR FILTER 5" PLASTIC	1
2	64.1694	.BRACKET, AIR CLEANER MOUNT	1
3	13.809670	.CLEANER, AIR ASM.	1
4	95.05	.WASHER, FLAT 5/16 SAE	4
5	90.0508	.BOLT, 5/16-18 USS X 1"	2
6	99.SF05	.NUT, SRF 5/16-18 USS.	4
7	90.0506	.BOLT, 5/16-18 USS X 3/4"	2
8	11.0044	.CLAMP, HOSE S/S 1-9/16- 2-1/2	1
9	14.0026-4	.HOSE, AIR CLEANER	1
10	13.0272	.HOSE, INTAKE 4500P	1
11	11.0050	.CLAMP, HOSE S/S 2 1/16 X 3"	2
30	13.533761	.CLEANER, AIR ASM - KUBOTA CAP	1
31	13.538928	.LATCH	2
32	13.0061	.FILTER, AIR-ELEMENT SAFETY	1
33	13.0060	.FILTER, AIR-ELEMENT PRIMARY	1
34	13.522958	.VALVE, DRAIN	1

ENGINES

ILLUSTRATED DRAWING 4500P Kawasaki Fuel System

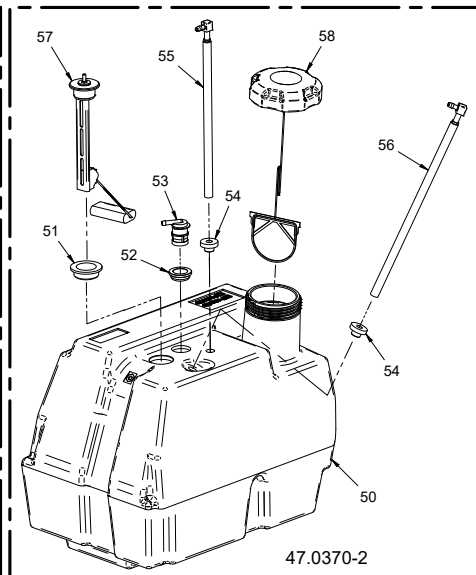
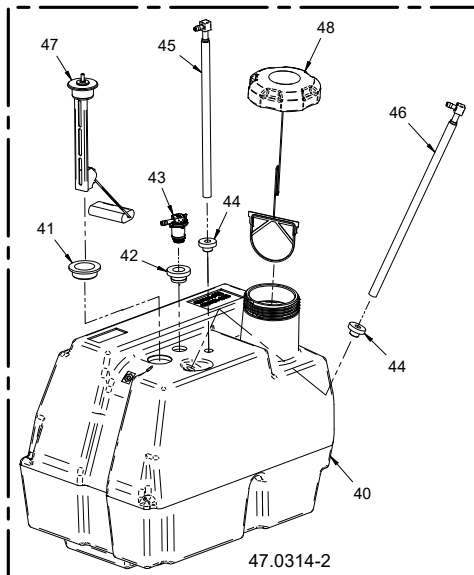
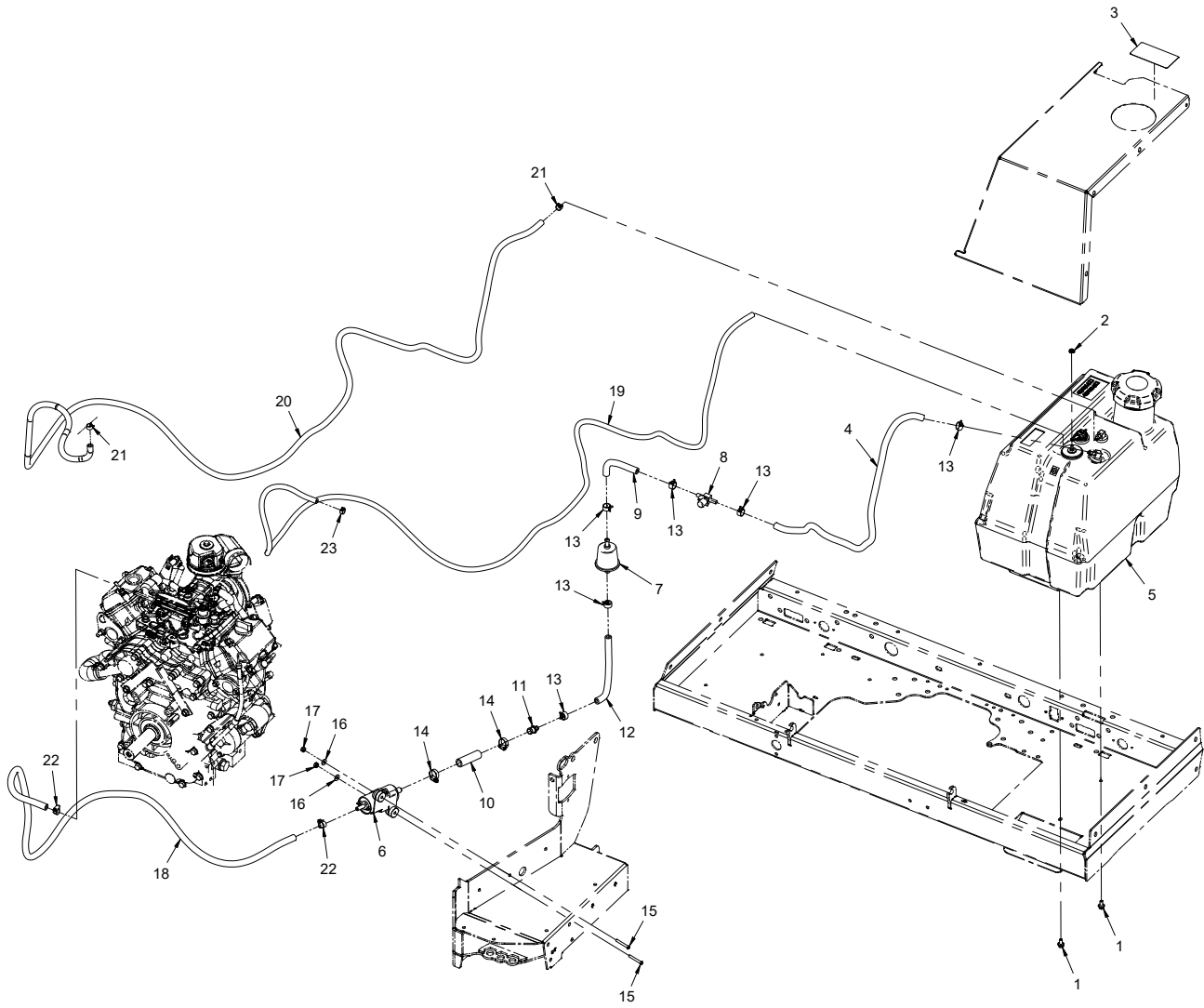

ENGINES

4500P Kawasaki Fuel System

REF.	PART NO.	DESCRIPTION	QTY.
1	99.SF0404-1	.BOLT, SMF 1/4-20 X 1/2	2
2	99.E0049	.NUT, WASHER #10-32 (STAR NUT)	1
3	00.0332	.DECAL, GASOLINE ONLY (Serial # 01001-14497)	1
3	00.0457	.DECAL, GASOLINE SAFETY (Serial # 14498-)	1
4	27.F05-1-26IN	.HOSE, FUEL LINE 5/16" LOW PERM X 26"	1
5	47.0314-2	.TANK, ASM 4500 GAS W/ RETURN (Serial # 01001-04349)	1
5	47.0370-2	.TANK, ASM 4500 GAS W/ RETURN (Serial # 04350-)	1
6	13.0269	.PUMP, FUEL KAW - P.	1
7	13.0053	.FILTER, FUEL - IN LINE 5/16"	1
8	47.0328	.VALVE, FUEL SHUT OFF 5/16"	1
9	27.F05-1-7IN	.HOSE, FUEL LINE 5/16" LOW PERM X 7"	1
10	27.F08-1-2.5IN	.HOSE, FUEL LINE 1/2" LOW PERM X 2-1/2"	1
11	13.59071-2141	.FITTING, ADAPTER FUEL PUMP.	1
12	27.F05-1-7IN	.HOSE, FUEL LINE 5/16" LOW PERM X 7"	1
13	11.0048	.CLAMP, HOSE BAND 9/16" OD HOSE	6
14	11.0032	.CLAMP, HOSE S/S 7/16-25/32	2
15	99.K0067	.MACHINE SCREW, #10-32 X 1-1/2	2
16	99.B0051	.WASHER, FLAT #10	2
17	99.A1032N	.LOCKNUT, NYLON 10-32 STAINLESS	2
18	27.F05-1-56IN	.HOSE, FUEL LINE 5/16" LOW PERM X 56"	1
19	27.F03-103IN	.HOSE, FUEL LINE X 3/16" X 103"	1
20	27.F04-1-114IN	.HOSE, FUEL LINE 1/4" LOW PERM X 114"	1
21	11.0049	.CLAMP, HOSE BAND 1/2" OD HOSE	2
22	11.0038	.CLAMP, HOSES S/S 7/32 - 5/8.	2
23	11.0073	.CLAMP, HOSE BAND 7/16" OD HOSE	1
40	N/A	.TANK, FUEL 4500 GASOLINE	1
41	05.0134	.GROMMET, TANK FUEL SENDER	1
42	05.0128	.GROMMET, FUEL TANK VENT VALVE	1
43	29.0094	.VENT, FUEL TANK BREATHER	1
44	05.0133	.GROMMET, TANK FITTING	2
45	29.0096	.FITTING, 1/4" TANK RETURN	1
46	29.0097	.FITTING, TANK 5/16 WITHDRAW	1
47	35.0120	.SENDING UNIT, FUEL	1
48	47.0309	.CAP, FUEL 3-1/2" UNVENTED	1
50	N/A	.TANK, FUEL 4500 GASOLINE	1
51	05.0134	.GROMMET, TANK FUEL SENDER	1
52	05.0162	.GROMMET, FUEL VENT VALVE	1
53	29.0100	.VALVE, FUEL VENT	1
54	05.0133	.GROMMET, TANK FITTING	2
55	29.0096	.FITTING, 1/4" TANK RETURN	1
56	29.0097	.FITTING, TANK 5/16 WITHDRAW	1
57	35.0120	.SENDING UNIT, FUEL	1
58	47.0309	.CAP, FUEL 3-1/2" UNVENTED	1

FRAMES / SHEET METAL

ILLUSTRATED DRAWING Lower Rear Frame

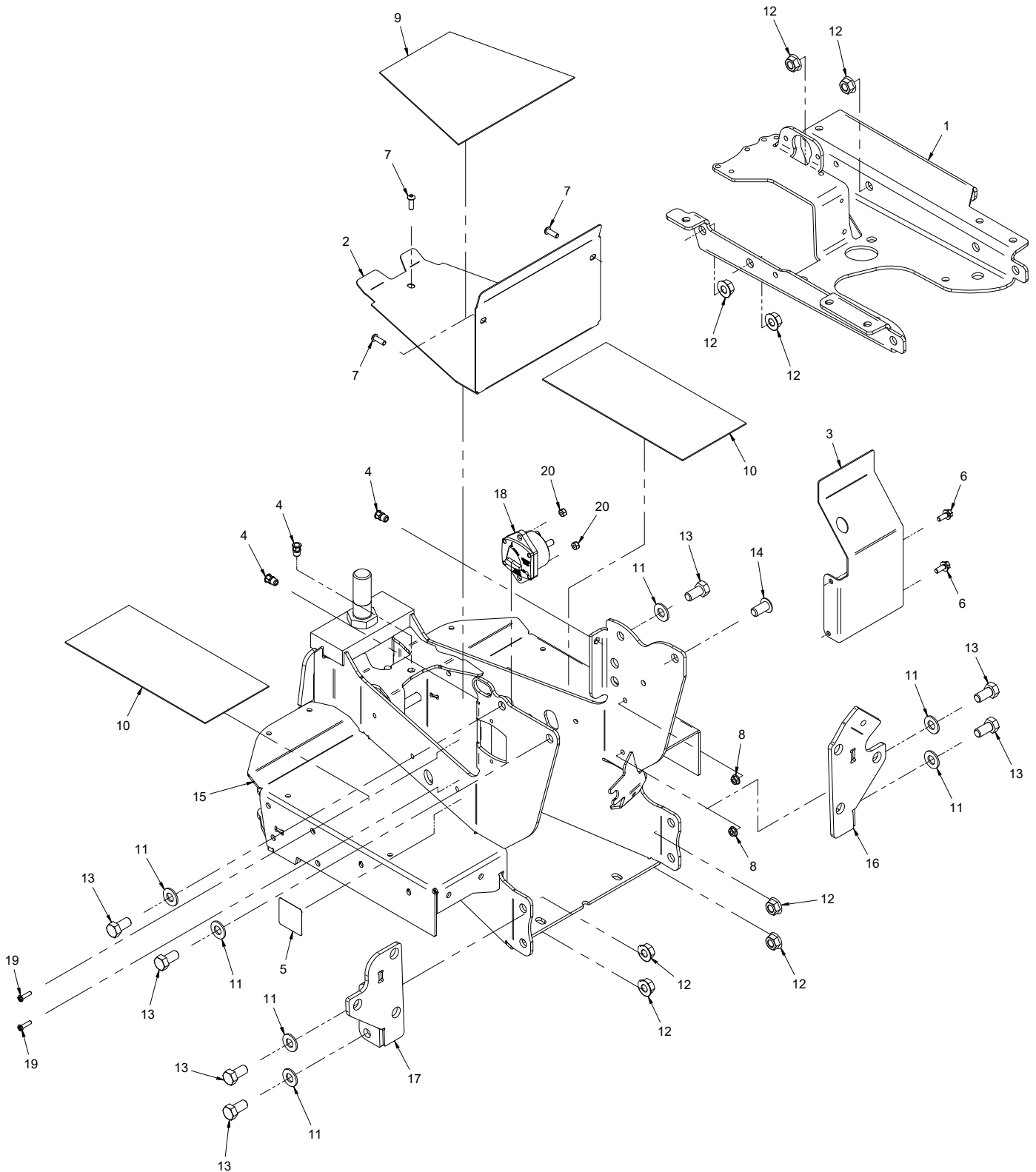

FRAMES / SHEET METAL

Lower Rear Frame

REF.	PART NO.	DESCRIPTION	QTY.
1	62.1368	.FRAME, REAR UPPER (Serial # 01001-01374)	1
1	62.1394	.FRAME, REAR UPPER (Serial # 01375-)	1
2	60.1118	.COVER, REAR LOWER FRAME	1
3	60.1119	.PANEL, FOOT PLATFORM RIGHT	1
4	99.E0105	.NUT, INSERT 1/4-20 HEX	3
5	00.0315	.DECAL, BATTERY DISCONNECT	1
6	99.SF0405-1	.BOLT, SMF 1/4-20 X 5/8	2
7	99.0406	.BOLT, 1/4-20 X 3/4 BSCS	3
8	99.SF04	.NUT, SRF 1/4-20 USS	2
9	44.0220	.FLEX TREAD, TUNNEL COVER	1
10	44.0331	.FLEX TREAD, FOOT PLATFORM KN	2
11	95.08	.WASHER, FLAT 1/2 SAE	7
12	99.SF08	.NUT, SRF 1/2-13 USS	8
13	90.0808	.BOLT, 1/2-13 USS X 1	7
14	99.0808	.BOLT, 1/2-13 X 1 BSCS	1
15	62.1369	.FRAME, REAR LOWER	1
16	64.1595	.BRACKET, TRANSAXLE MOUNT RIGHT	1
17	64.1594	.BRACKET, TRANSAXLE MOUNT LEFT	1
18	30.0338	.BREAKER, CIRCUIT 150 AMP	1
19	99.K0047	.MACHINE SCREW, #10-32 X 3/4	2
20	99.A1032N	.LOCKNUT, NYLON 10-32 STAINLESS	2

FRAMES / SHEET METAL

ILLUSTRATED DRAWING Seat Box & Upper Rear Frame

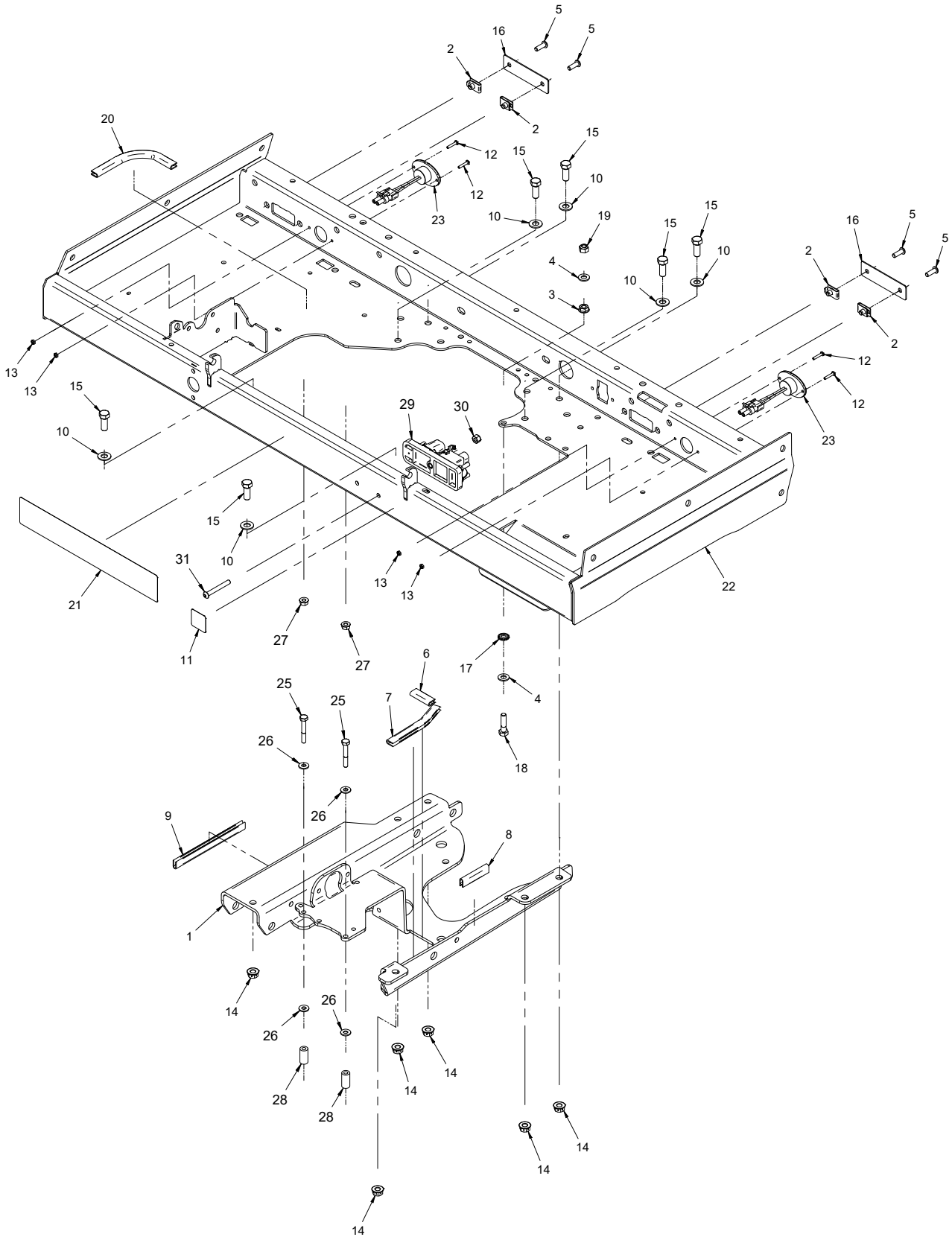

FRAMES / SHEET METAL

Seat Box & Upper Rear Frame

REF.	PART NO.	DESCRIPTION	QTY.
1	62.1368	.FRAME, REAR UPPER (Serial # 01001-01374)	1
1	62.1394	.FRAME, REAR UPPER (Serial # 01375-)	1
2	99.E0046	.NUT, "U" 1/4-20 EXTRUDED	4
3	99.SF05	.NUT, SRF 5/16-18 USS	5
4	95.05	.WASHER, FLAT 5/16 SAE	6
5	99.0406	.BOLT, 1/4-20 X 3/4 BSCS	4
6	06.0050-1.63IN	.TRIM, TRIM LOC 1/2 X 3/16 X 1-5/8"	1
7	06.0050-4.5IN	.TRIM, TRIM LOC 1/2 X 3/16 X 4-1/2"	1
8	06.0050-2.25IN	.TRIM, TRIM LOC 1/2 X 3/16 X 2-1/4"	1
9	06.0050-6IN	.TRIM, TRIM LOC 1/2 X 3/16 X 6"	1
10	95.06	.WASHER, FLAT 3/8 SAE	6
11	00.0334	.DECAL, FUEL ON/OFF	1
12	99.K0060	.MACHINE SCREW, #6-32 X 3/4	4
13	99.E0085	.LOCKNUT, NYLON #6-32	4
14	99.E0082	.NUT, LOCKING FLANGE 3/8-16	6
15	90.0608	.BOLT, 3/8-16 USS X 1	6
16	60.1174	.COVER, OPT. LIGHT KIT HOLE	2
17	99.G0003	.WASHER, STAR-EXTERNAL 5/16	1
18	90.0510	.BOLT, 5/16-18 USS X 1-1/4"	1
19	99.A05N	.LOCKNUT, NYLON 5/16-18 USS	1
20	06.0050-6IN	.TRIM, TRIM LOC 1/2 X 3/16 X 6"	1
21	00.0336	.DECAL, SAFETY 4500	1
22	62.1370	.FRAME, SEATBOX	1
23	33.0061	.LIGHT, MARKER RED OVAL	2
25	90.0414	.BOLT, 1/4-20 USS X 1-3/4"	2
26	95.04	.WASHER, FLAT 1/4 SAE	4
27	99.E0101	.NUT, LOCKING FLANGE 1/4-20	2
28	05.0065	.SPACER, 1/4 ID X 1/2 OD X 1 LG	2
29	30.0339	.MODULE, POWER RELAY	1
30	99.A04N	.LOCKNUT, NYLON 1/4-20	1
31	99.0416	.BOLT, 1/4-20 X 2 BSCS	1

FRAMES / SHEET METAL

ILLUSTRATED DRAWING Left Seat Box Panels

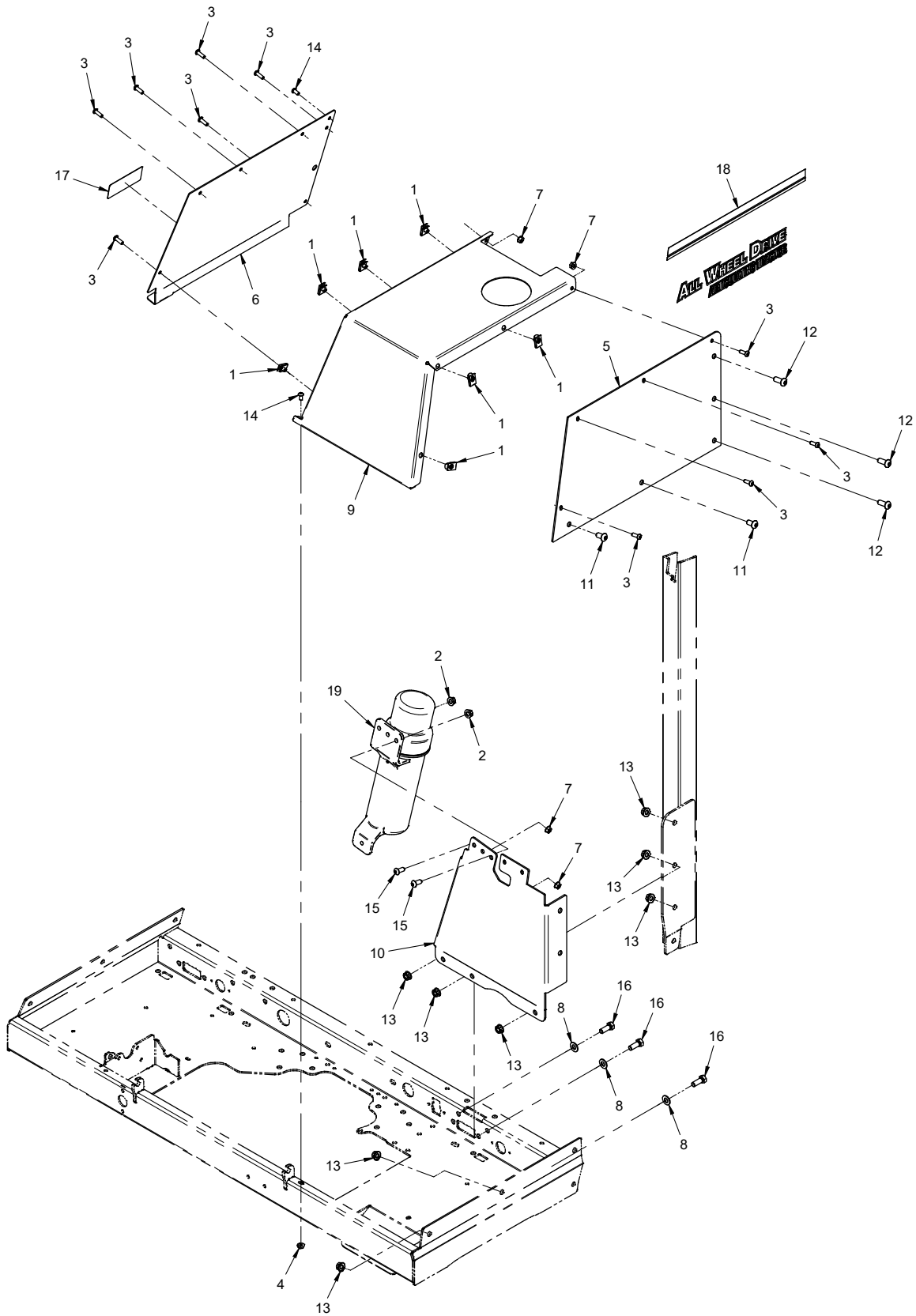

FRAMES / SHEET METAL

Left Seat Box Panels

REF.	PART NO.	DESCRIPTION	QTY.
1	99.E0046	.NUT, "U" 1/4-20 EXTRUDED	7
2	99.E0102	.NUT, LOCKING FLANGE 5/16-18	2
3	99.0406	.BOLT, 1/4-20 X 3/4 BSCS	10
4	99.SF04	.NUT, SRF 1/4-20 USS	1
5	60.1148	.PANEL, SEATBOX LEFT	1
6	60.1125	.COVER, FUEL TANK INNER	1
7	99.E0101	.NUT, LOCKING FLANGE 1/4-20	4
8	95.06	.WASHER, FLAT 3/8 SAE	3
9	60.1123	.COVER, FUEL TANK MAIN	1
10	60.1149	.PANEL, SEATBOX REAR LEFT	1
11	99.0606	.BOLT, 3/8-16 X 3/4 BSCS	2
12	99.0608	.BOLT, 3/8-16 X 1 BSCS	3
13	99.E0082	.NUT, LOCKING FLANGE 3/8-16	8
14	99.0404	.BOLT, 1/4-20 X 1/2 BSCS	2
15	99.0506	.BOLT, 5/16-18 X 3/4 BSCS	2
16	90.0608	.BOLT, 3/8-16 USS X 1	3
17	00.0345	.DECAL, DANGER BATTERY (Serial # 01001-14497)	1
17	00.0629	.DECAL, BATTERY HAZARD (Serial # 14498-)	1
18	00.0301	.DECAL, REAR LEFT	1
19	47.0323	.CONTAINER, MANUAL HOLDER	1

FRAMES / SHEET METAL

ILLUSTRATED DRAWING Right Seat Box Panels

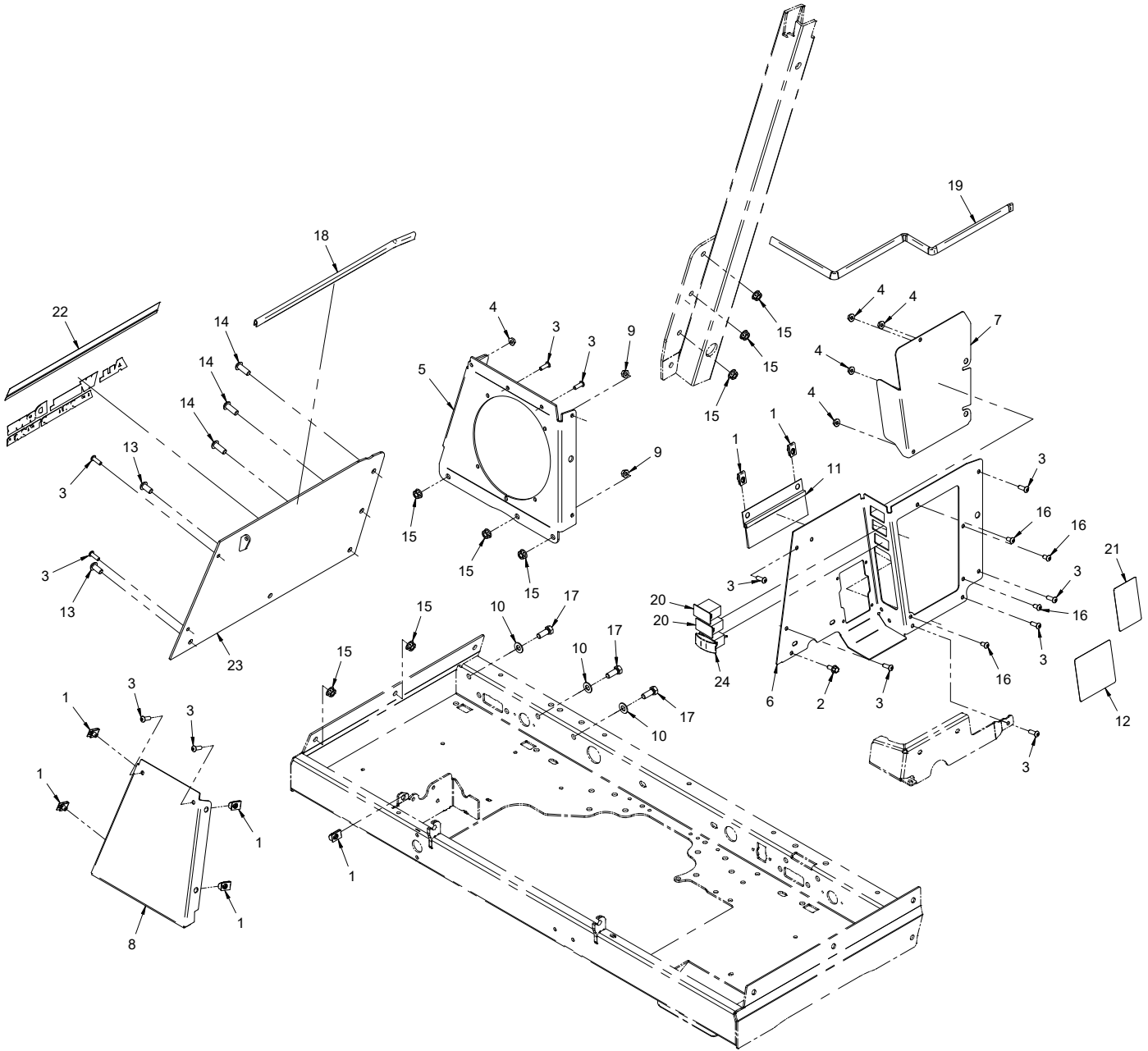

FRAMES / SHEET METAL

Right Seat Box Panels

REF.	PART NO.	DESCRIPTION	QTY.
1	99.E0046	.NUT, "U" 1/4-20 EXTRUDED	7
2	99.SF0405-1	.BOLT, SMF 1/4-20 X 5/8	1
3	99.0406	.BOLT, 1/4-20 X 3/4 BSCS	12
4	99.SF04	.NUT, SRF 1/4-20 USS	5
5	60.1150	.PANEL, SEATBOX REAR RIGHT	1
6	60.1124	.PANEL, TOOLBOX INNER	1
7	64.1596	.SCREEN, HYD. OIL COOLER	1
8	60.1128	.PANEL, TOOLBOX FRONT BASIC	1
9	99.E0101	.NUT, LOCKING FLANGE 1/4-20	2
10	95.06	.WASHER, FLAT 3/8 SAE	3
11	79.0093	.BRUSH, SIDE PANEL W/HOLDER	1
12	00.0316	.DECAL, SDLA	1
13	99.0606	.BOLT, 3/8-16 X 3/4 BSCS	2
14	99.0608	.BOLT, 3/8-16 X 1 BSCS	3
15	99.E0082	.NUT, LOCKING FLANGE 3/8-16	8
16	99.0404	.BOLT, 1/4-20 X 1/2 BSCS	4
17	90.0608	.BOLT, 3/8-16 USS X 1	3
18	06.0050-16.5IN	.TRIM, TRIM LOC 1/2 X 3/16 X 16-1/2"	1
19	06.0042-24.5IN	.TRIM, TRIM LOC 1/2 X 1/16 X 24-1/2"	1
20	05.0131	.PLUG, SWITCH OTTO K5	2
21	00.0306	.DECAL, REAR CONTROL	1
22	00.0302	.DECAL, REAR RIGHT	1
23	60.1147	.PANEL, SEATBOX RIGHT	1
24	31.0053	.SWITCH, ROCKER ON/OFF	1

FRAMES / SHEET METAL

ILLUSTRATED DRAWING Tool Box Lid & Liner Panels

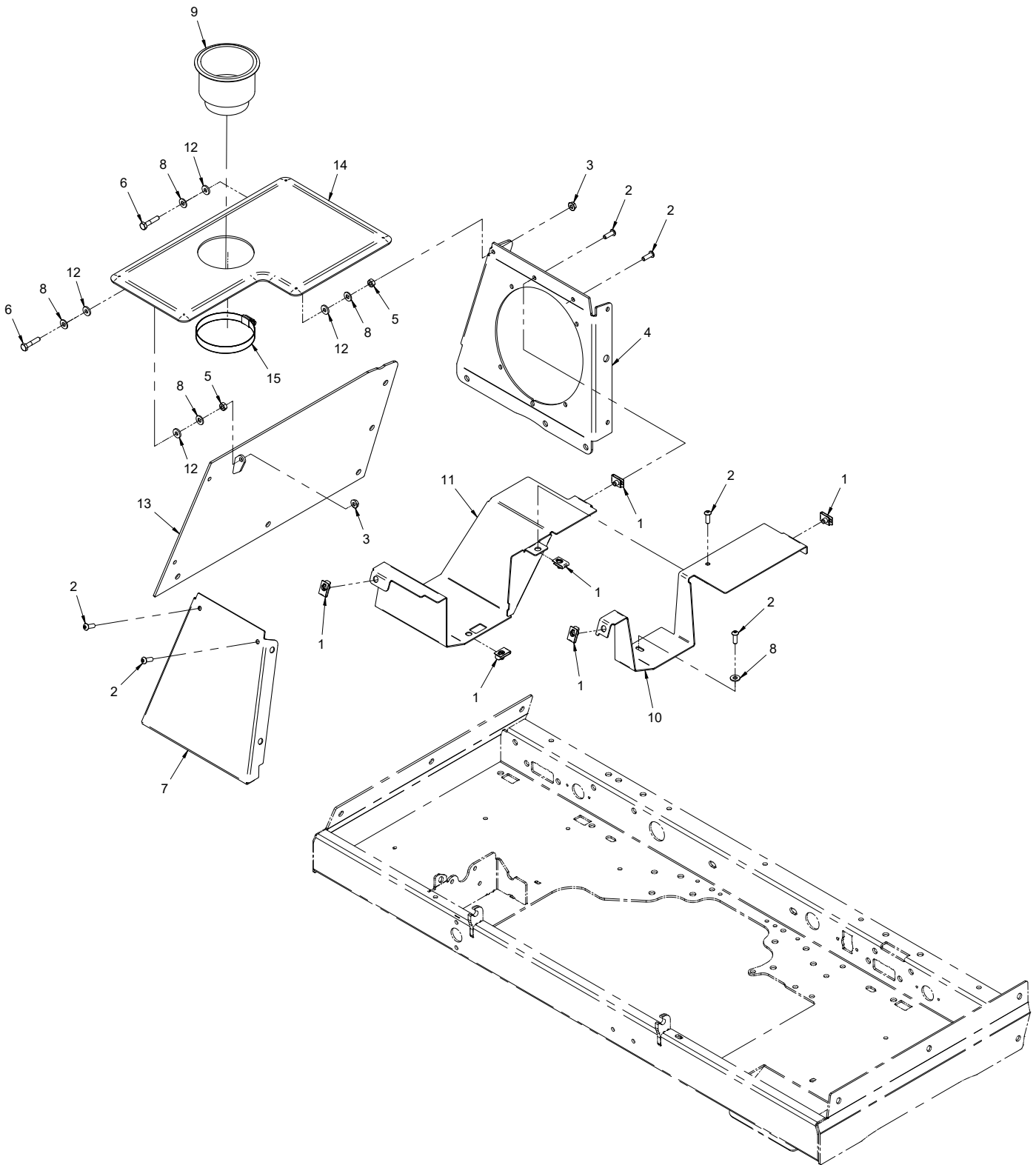

FRAMES / SHEET METAL

Tool Box Lid & Liner Panels

REF.	PART NO.	DESCRIPTION	QTY.
1	99.E0046	.NUT, "U" 1/4-20 EXTRUDED	6
2	99.0406	.BOLT, 1/4-20 X 3/4 BSCS	6
3	99.SF04	.NUT, SRF 1/4-20 USS	2
4	60.1150	.PANEL, SEATBOX REAR RIGHT	1
5	92.04	.NUT, 1/4-20 USS	2
6	90.0410	.BOLT, 1/4-20 USS X 1/1-4"	2
7	60.1128	.PANEL, TOOLBOX FRONT BASIC	1
8	95.04	.WASHER, FLAT 1/4 SAE	5
9	47.0185	.HOLDER, CUP 3.586 OD X 3-1/4 DP	1
10	60.1152	.PANEL, TOOLBOX LINER LEFT	1
11	60.1153	.PANEL, TOOLBOX LINER RIGHT	1
12	05.0126	.WASHER, NEOPRENE 1/4 X 5/8	4
13	60.1147	.PANEL, SEATBOX RIGHT	1
14	60.1126	.COVER, TOOLBOX	1
15	11.0077	.CLAMP, HOSE 3-1/16" - 4" (Serial # 03012-)	1

FRAMES / SHEET METAL

ILLUSTRATED DRAWING Roll Bar

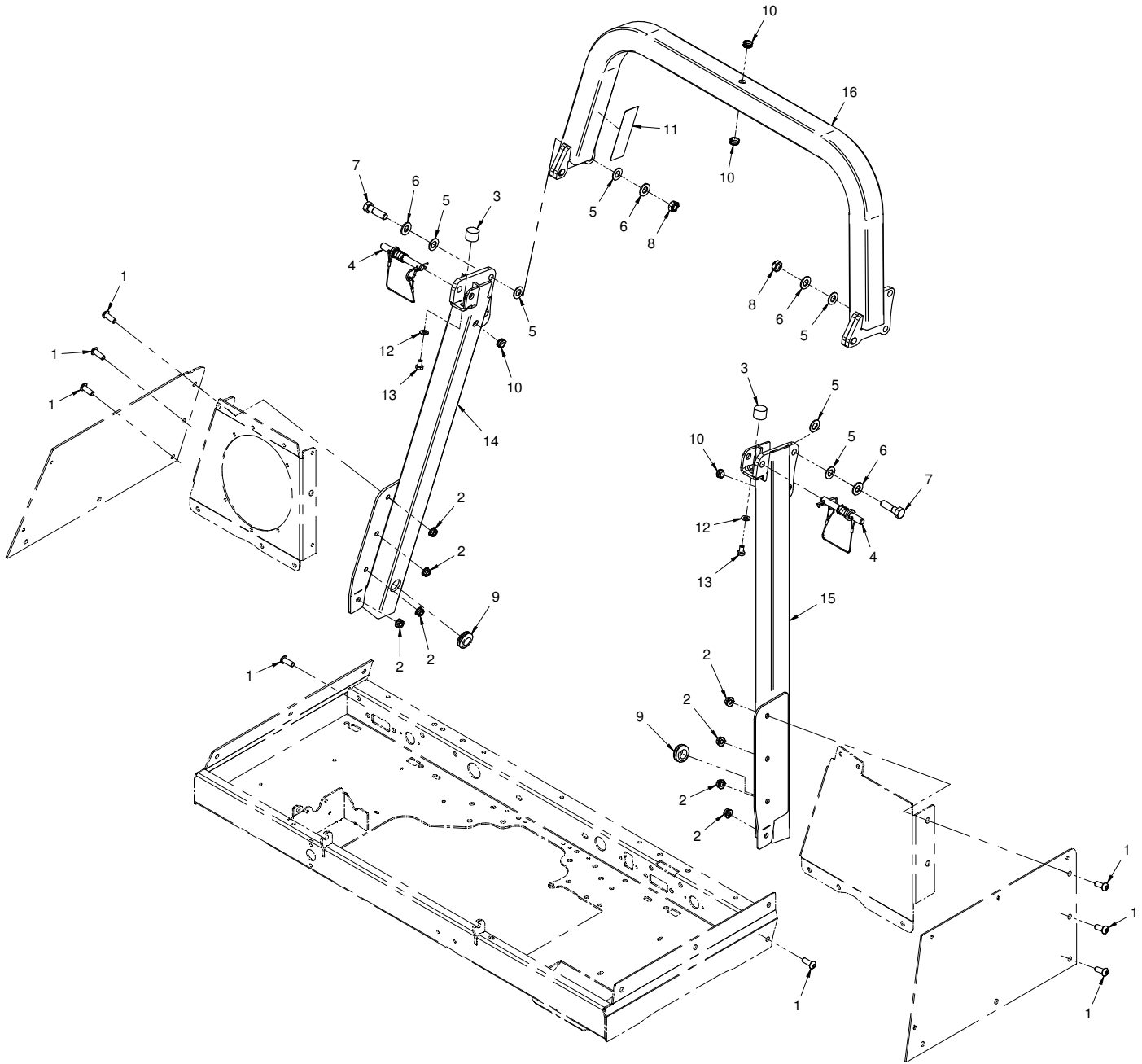

FRAMES / SHEET METAL

Roll Bar

REF.	PART NO.	DESCRIPTION	QTY.
1	99.0608	.BOLT, 3/8-16 X 1 BSCS	8
2	99.E0082	.NUT, LOCKING FLANGE 3/8-16	8
3	05.0110	.BUMPER, RUBBER 1" DIA	2
4	03.0037	.PIN, KNURLED W/SPRING & LANYARD	2
5	05.0145	.WASHER .55ID X 1.03OD X .062T	6
6	95.08	.WASHER, FLAT 1/2 SAE	4
7	90.0814	.BOLT, 1/2-13 USS X 1-3/4	2
8	99.A08	.LOCKNUT, STOVER 1/2-13 USS	2
9	05.0045	.GROMMET, 3/4ID, 1 3/8OD, 1/2THK	2
10	05.0138	.GROMMET, 7/16ID, 11/16OD, 3/8THK	4
11	00.0331	.DECAL, ROPS CERTIFICATION (Serial # 01001-14497)	1
11	00.0644	.DECAL, ROPS 4500 CERTIFICATION (Serial # 14498-)	1
12	95.05	.WASHER, FLAT 5/16 SAE	2
13	90.0504	.BOLT, 5/16-18 USS X 1/2"	2
14	62.1381	.ROLLBAR, FOLD DOWN RIGHT	1
15	62.1382	.ROLLBAR, FOLD DOWN LEFT	1
16	62.1380	.ROLLBAR, FOLD DOWN TOP	1

FRAMES / SHEET METAL

ILLUSTRATED DRAWING Standard Rear Hitch

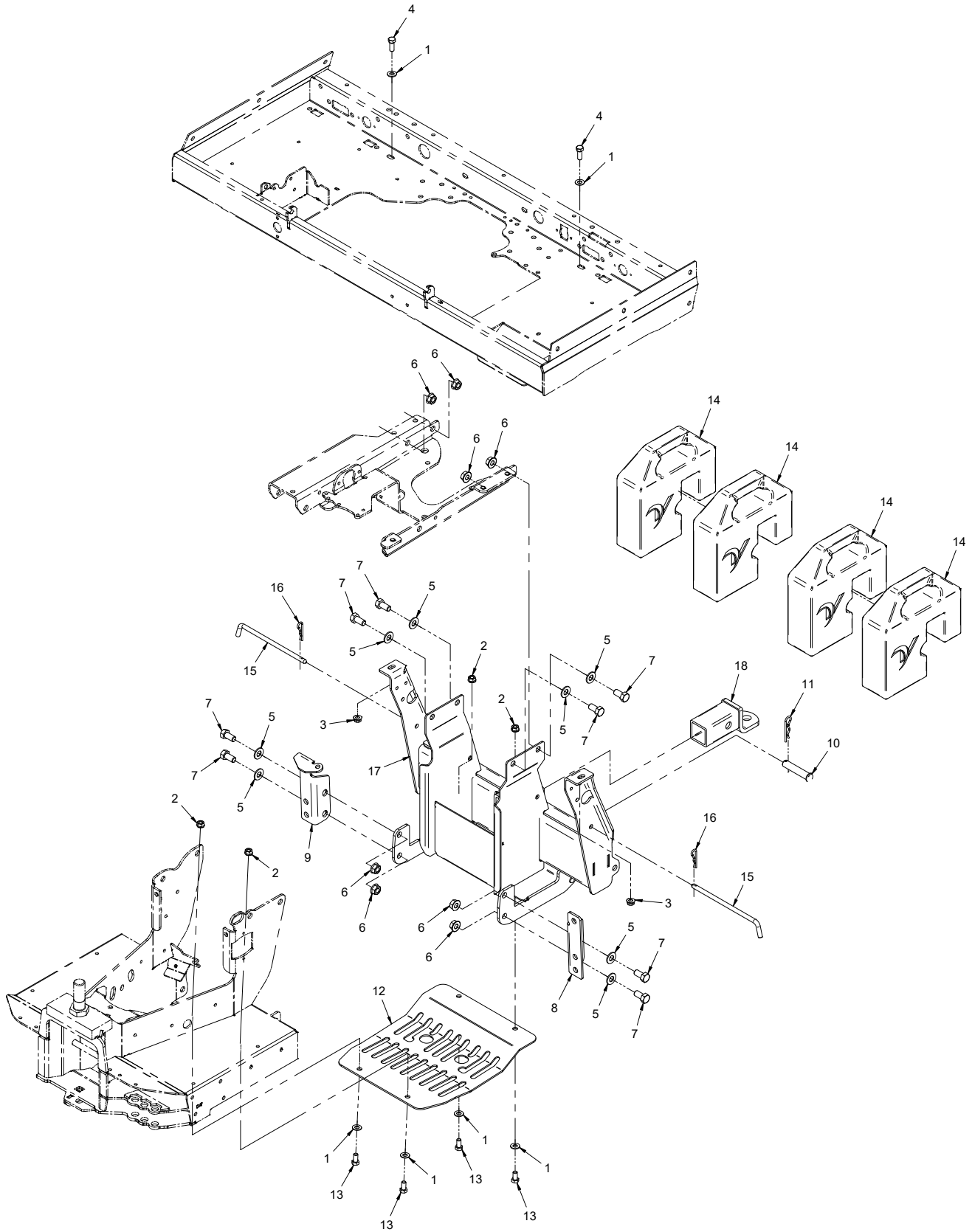

FRAMES / SHEET METAL

Standard Rear Hitch

REF.	PART NO.	DESCRIPTION	QTY.
1	95.06	.WASHER, FLAT 3/8 SAE	6
2	99.SF06	.NUT, SRF 3/8-16 USS	4
3	99.E0082	.NUT, LOCKING FLANGE 3/8-16	2
4	90.0608	.BOLT, 3/8-16 USS X 1	2
5	95.08	.WASHER, FLAT 1/2 SAE	8
6	99.SF08	.NUT, SRF 1/2-13 USS	8
7	90.0808	.BOLT, 1/2-13 USS X 1	8
8	64.1592	.BRACKET, REAR HITCH MT LEFT (Serial # 01001-02923)	1
8	64.1865	.BRACKET, REAR HITCH MT LEFT (Serial # 02924-)	1
9	64.1591	.BRACKET, REAR HITCH MT RIGHT (Serial # 01001-02923)	1
9	64.1866	.BRACKET, REAR HITCH MT RIGHT (Serial # 02924-)	1
10	03.1024	.CLEVIS PIN, 5/8 X 3 OAL	1
11	02.HP0420	.HAIRPIN, 1/8 X 2 1/2	1
12	64.1679	.PLATE, REAR AXLE SKID NO3PT (Serial # 01001-02923)	1
12	64.1867	.PLATE, REAR AXLE SKID NO3PT (Serial # 02924-)	1
13	90.0606	.BOLT, 3/8-16 USS X 3/4	4
14	47.0115-1	.WEIGHT, SUITCASE - 42 LBS	4
15	64.0761	.PIN, WEIGHT SECURE 7.3" USEABLE	2
16	02.HP0416	.HAIRPIN, 1/8 X 2	2
17	62.1363	.FRAME, REAR WEIGHT BAR/HITCH	1
18	62.0968	.HITCH, REAR	2

FRAMES / SHEET METAL

ILLUSTRATED DRAWING Rear Fenders & Battery Compartment

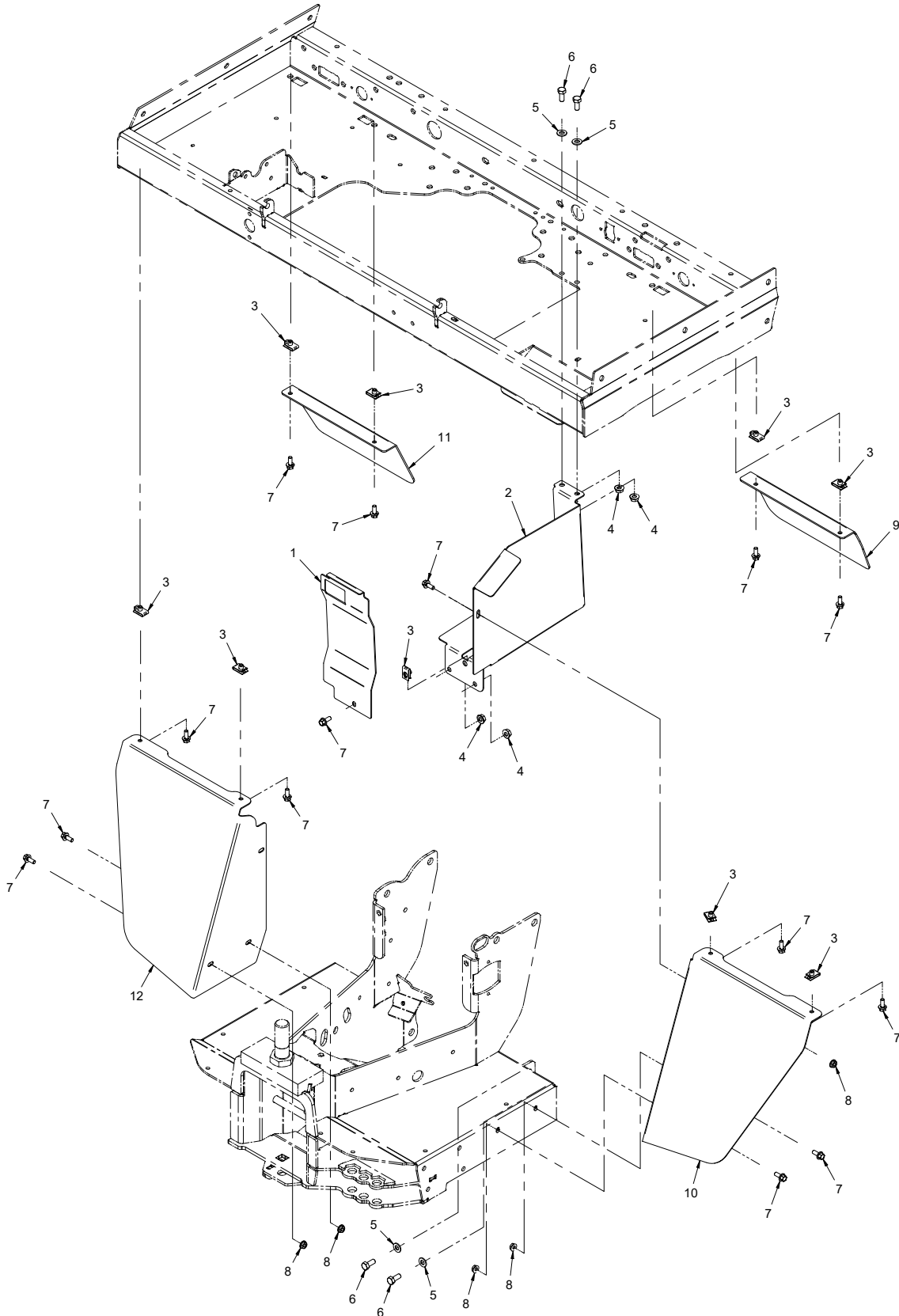

FRAMES / SHEET METAL

Rear Fenders & Battery Compartment

REF.	PART NO.	DESCRIPTION	QTY.
1	60.1117	.PANEL, FOOT PLATFORM LEFT	1
2	60.1116	.PANEL, BATTERY COMPARTMENT	1
3	99.E0046	.NUT, "U" 1/4-20 EXTRUDED	9
4	99.SF05	.NUT, SRF 5/16-18 USS	4
5	95.05	.WASHER, FLAT 5/16 SAE	4
6	90.0506	.BOLT, 5/16-18 USS X 3/4"	4
7	99.SF0405-1	.BOLT, SMF 1/4-20 X 5/8	14
8	99.SF04	.NUT, SRF 1/4-20 USS	5
9	60.1127	.FENDER, REAR FLAP LEFT	1
10	60.1130	.FENDER, REAR LEFT	1
11	60.1146	.FENDER, REAR FLAP RIGHT	1
12	60.1131	.FENDER, REAR RIGHT	1

FRAMES / SHEET METAL

ILLUSTRATED DRAWING Standard Seat Assembly

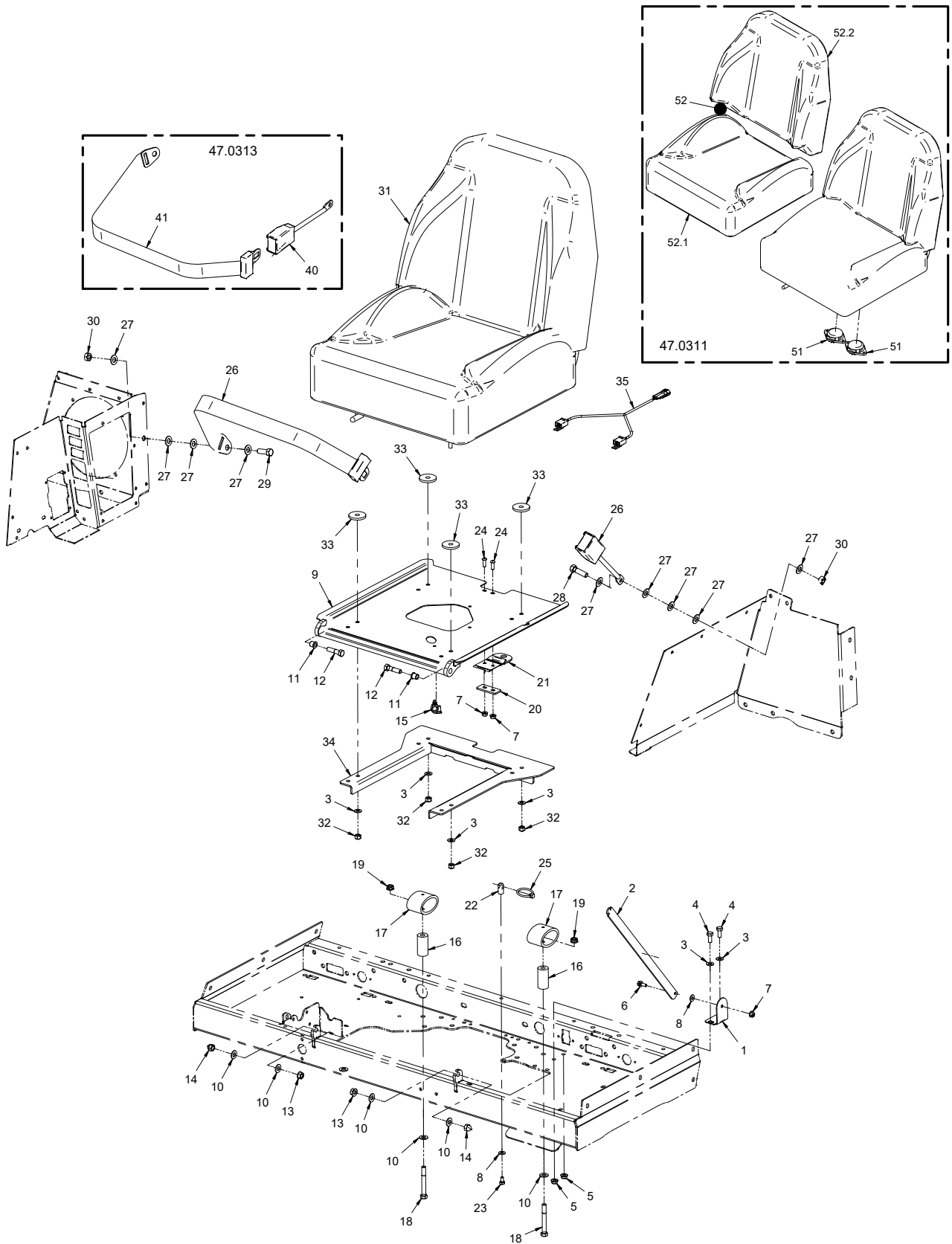

FRAMES / SHEET METAL

Standard Seat Assembly

REF.	PART NO.	DESCRIPTION	QTY.
1	64.1598	.BRACKET, SEAT PROP.	1
2	64.1599	.PLATE, SEAT PROP.	1
3	95.05	.WASHER, FLAT 5/16 SAE	6
4	90.0506	.BOLT, 5/16-18 USS X 3/4"	2
5	99.SF05	.NUT, SRF 5/16-18 USS	2
6	99.SF0405-1	.BOLT, SMF 1/4-20 X 5/8	1
7	99.E0101	.NUT, LOCKING FLANGE 1/4-20	3
8	95.04	.WASHER, FLAT 1/4 SAE	2
9	64.1597	.MOUNT, SEAT	1
10	95.06	.WASHER, FLAT 3/8 SAE	7
11	85.B0068	.BUSHING, 3/8 X 1/2 OD X 1/2 LG	2
12	90.0612	.BOLT, 3/8-16 USS X 1-1/2	2
13	99.SF06	.NUT, SRF 3/8-16 USS	2
14	99.E0100	.NUT, ACORN 3/8-16	2
15	30.0135	.CLAMP, LOOM 3/8 ROSEBUD MOUNT	1
16	64.1681	.TUBE, SEAT BUMPER	2
17	05.0137	.BUMPER, ELASTOMER 3.4"	2
18	90.0624	.BOLT, 3/8-16 USS X 3	2
19	99.E0082	.NUT, LOCKING FLANGE 3/8-16	2
20	64.1723	.CLAMP, SEAT LATCH STRAP	1
21	47.0335	.STRAP, SEAT LATCH	1
22	03.0019	.PIN, SEAT LATCH	1
23	90.0404	.BOLT, 1/4-20 USS X 1/2"	1
24	99.0406	.BOLT, 1/4-20 X 3/4 BSCS	2
25	03.0021	.PIN, LINCH	1
26	47.0313	.SEAT BELT, LAP W/BUCKLE	1
27	95.07	.WASHER, FLAT 7/16 SAE	9
28	90.0712	.BOLT, 7/16-14 USS X 1-1/2	1
29	90.0710	.BOLT, 7/16-14 USS X 1-1/4	1
30	99.A07	.LOCKNUT, STOVER 7/16-14 USS	2
31	47.0311	.SEAT, DELUXE HIGH BACK	1
32	99.A05N	.LOCKNUT, NYLON 5/16-18 USS	4
33	99.B0076	.WASHER, .140T X .395ID X 1.5OD	4
34	64.1684	.BRACKET, SEAT SUPPORT	1
35	32.0143	.HARNESS, 3400/4500 SEAT	1
40	47.0313-2	.SEAT BELT, BUCKLE	1
41	47.0313-1	.SEAT BELT, LAP BELT	1
51	31.0060	.SWITCH, SEAT	2
52	47.0347	.COVER, SEAT BOTTOM & BACK	1
52.1	47.0366	.COVER, SEAT BOTTOM	1
52.2	47.0409	.COVER, SEAT BACK FOR 47.0311	1

FRAMES / SHEET METAL

ILLUSTRATED DRAWING Front Frame, Frame Connector Bracket, Hose Retainer

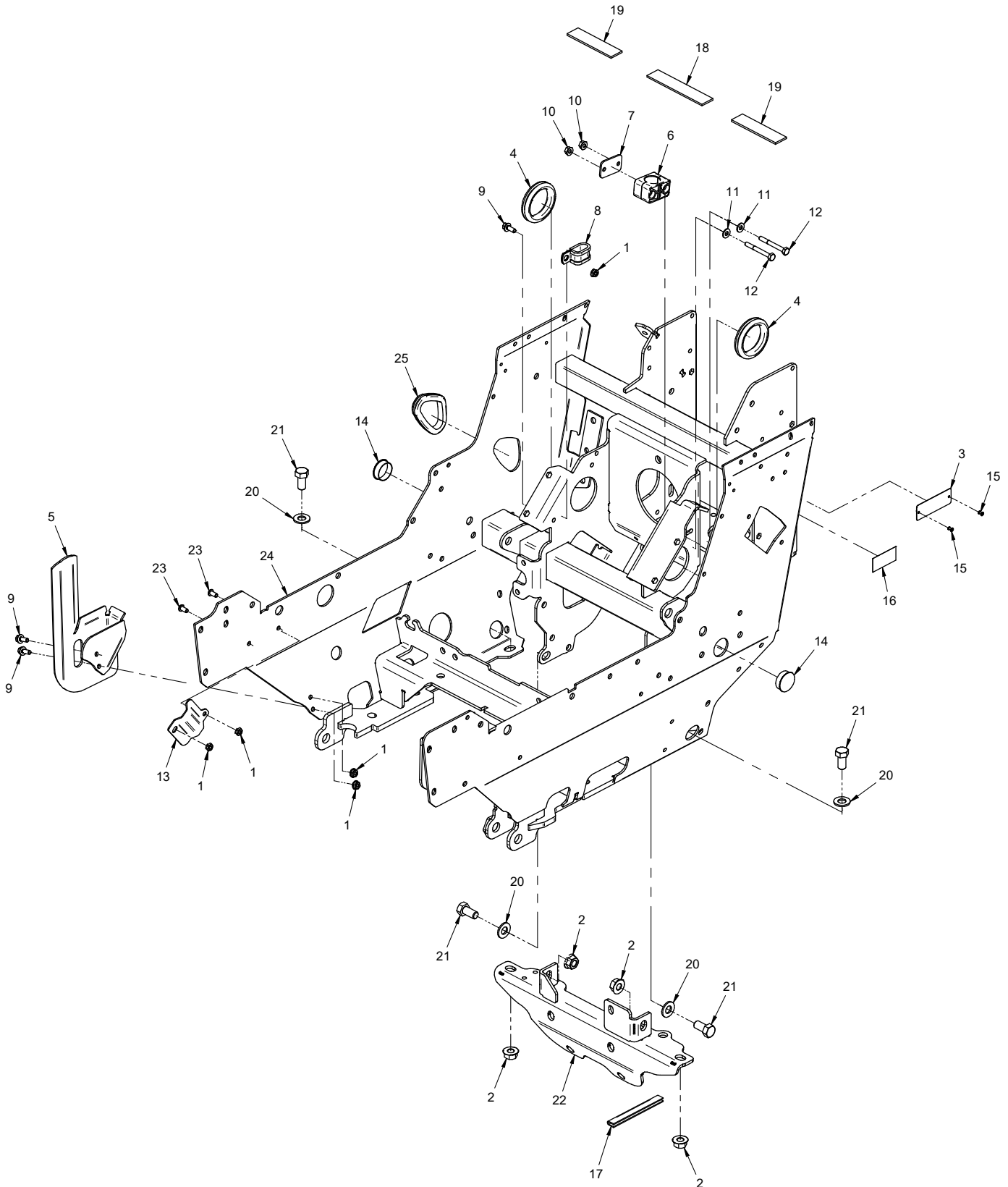

FRAMES / SHEET METAL

Front Frame, Frame Connector Bracket, Hose Retainer

REF.	PART NO.	DESCRIPTION	QTY.
1	99.SF04	.NUT, SRF 1/4-20 USS	5
2	99.SF08	.NUT, SRF 1/2-13 USS	4
3	N/A	.PLATE, VENTRAC SERIAL NUMBER	1
4	05.0073	.GROMMET, 2 ID, 2-3/4 OD 9/16 T	2
5	64.1827	.BRACKET, HOSE RETAINER	1
6	44.0320	.CLAMP, HYD HOSE 25.4MM ID	1
7	44.0321	.COVER PLATE, GROUP 3 (1)	1
8	11.0046	.CLAMP, CUSHIONED METAL 1/2"	1
9	99.SF0405-1	.BOLT, SMF 1/4-20 X 5/8	3
10	99.E0101	.NUT, LOCKING FLANGE 1/4-20	2
11	95.04	.WASHER, FLAT 1/4 SAE	2
12	90.0418	.BOLT, HEX 1/4-20 UNC X 2-1/4"	2
13	64.1729	.RETAINER, WIRE LOOM	1
14	05.0091	.PLUG, 1-1/4" HOLE, BLK PLASTIC	2
15	04.0029	.RIVET, POP 1/8" X 1/4"	2
16	00.0100	.DECAL, MADE IN USA	1
17	06.0050-4.5IN	.TRIM, TRIM LOC 1/2 X 3/16 X 4-1/2"	1
18	06.0065-5IN	.VELCRO, LOOP 1" BLACK X 5"	1
19	06.0065-4IN	.VELCRO, LOOP 1" BLACK X 4"	2
20	95.08	.WASHER, FLAT 1/2 SAE	4
21	90.0808	.BOLT, HEX 1/2-13 UNC X 1	4
22	64.1613	.BRACKET, CONNECTOR FRAME MT (Serial # 01001-03011)	1
22	64.1863	.BRACKET, CONNECTOR FRAME MT (Serial # 03012-)	1
23	99.0404	.BOLT, 1/4-20 X 1/2 BSCS	2
24	62.1373	.FRAME, MAIN FRONT	1
25	05.0148	.GROMMET, 2-1/2ID, 3-1/8OD, 3/8T	1

FRAMES / SHEET METAL

ILLUSTRATED DRAWING Front Fenders & Foot Pegs

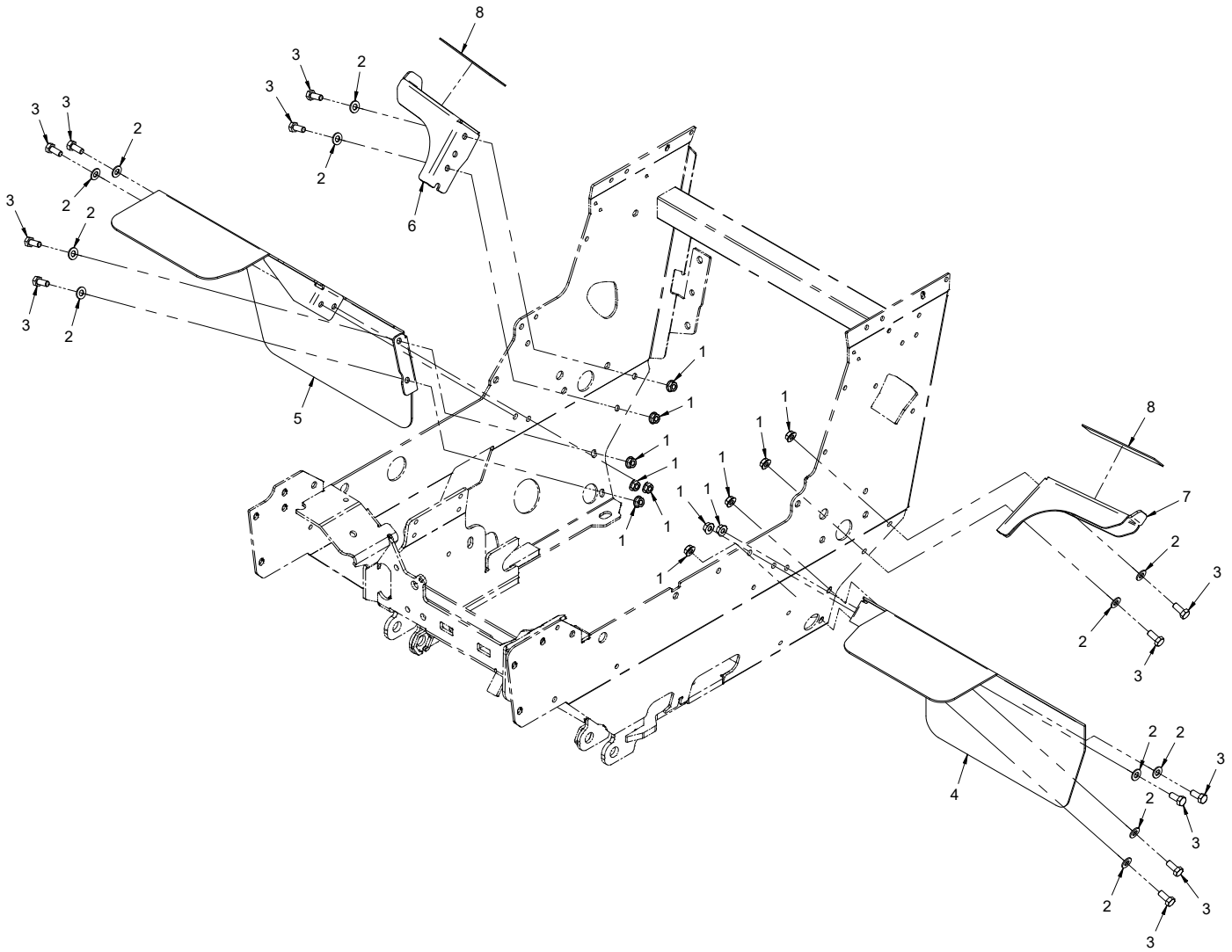

FRAMES / SHEET METAL

Front Fenders & Foot Pegs

REF.	PART NO.	DESCRIPTION	QTY.
1	99.SF05	.NUT, SRF 5/16-18 USS	12
2	95.05	.WASHER, FLAT 5/16 SAE	12
3	90.0506	.BOLT, 5/16-18 USS X 3/4"	12
4	60.1133	.FENDER, FRONT LEFT	1
5	60.1134	.FENDER, FRONT RIGHT	1
6	64.1707	.FOOT PEG, RIGHT	1
7	64.1708	.FOOT PEG, LEFT	1
8	44.0330	.FLEX TREAD, FOOT PEG	2

FRAMES / SHEET METAL

ILLUSTRATED DRAWING Center Pivot & Connector Link

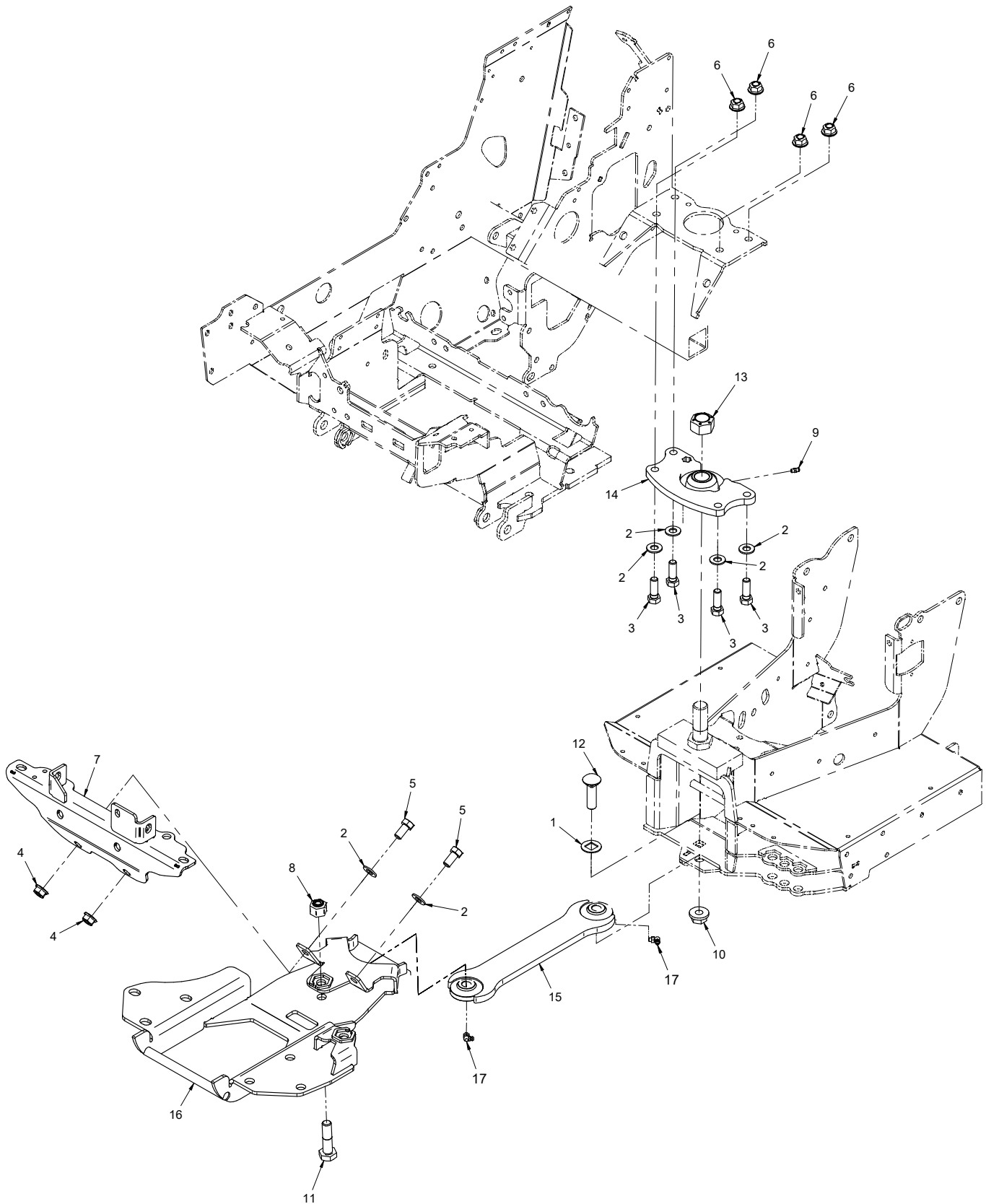

FRAMES / SHEET METAL

Center Pivot & Connector Link

REF.	PART NO.	DESCRIPTION	QTY.
1	64.1724	.SPACER, CONNECTOR LINK BOLT	1
2	95.08	.WASHER, FLAT 1/2 SAE	6
3	90.0812	.BOLT, 1/2-13 USS X 1-1/2	4
4	99.SF08	.NUT, SRF 1/2-13 USS	2
5	90.0808	.BOLT, 1/2-13 USS X 1	2
6	99.E0103	.NUT, LOCKING FLANG 1/2-13	4
7	64.1613	.BRACKET, CONNECTOR FRAME MT (Serial # 01001-03011)	1
7	64.1863	.BRACKET, CONNECTOR FRAME MT (Serial # 03012-)	1
8	99.E0095	.LOCKNUT, 5/8-11 HEAVY NYLON	1
9	29.GF0001	.GREASE FTG, 1/4 SAE ST	1
10	99.E0094	.LOCKNUT, 5/8-11 FLANGED STOVER	1
11	99.K0112	.BOLT, 5/8-11 X 2-1/2 GRD A325	1
12	97.1018	.BOLT, CARRIAGE 5/8-11 X 2-1/4 GR5	1
13	99.A16NF	.LOCKNUT, STOVER 1" SAE	1
14	42.0553	.PIVOT, CENTER MAIN	1
15	42.0560	.LINK, FRONT/REAR CONNECTOR	1
16	62.1371	.FRAME, CONNECTOR LINK MOUNT	1
17	29.GF0002	.GREASE, FTG. 1/4 SAE 90	2

FRAMES / SHEET METAL

ILLUSTRATED DRAWING Front Hitch

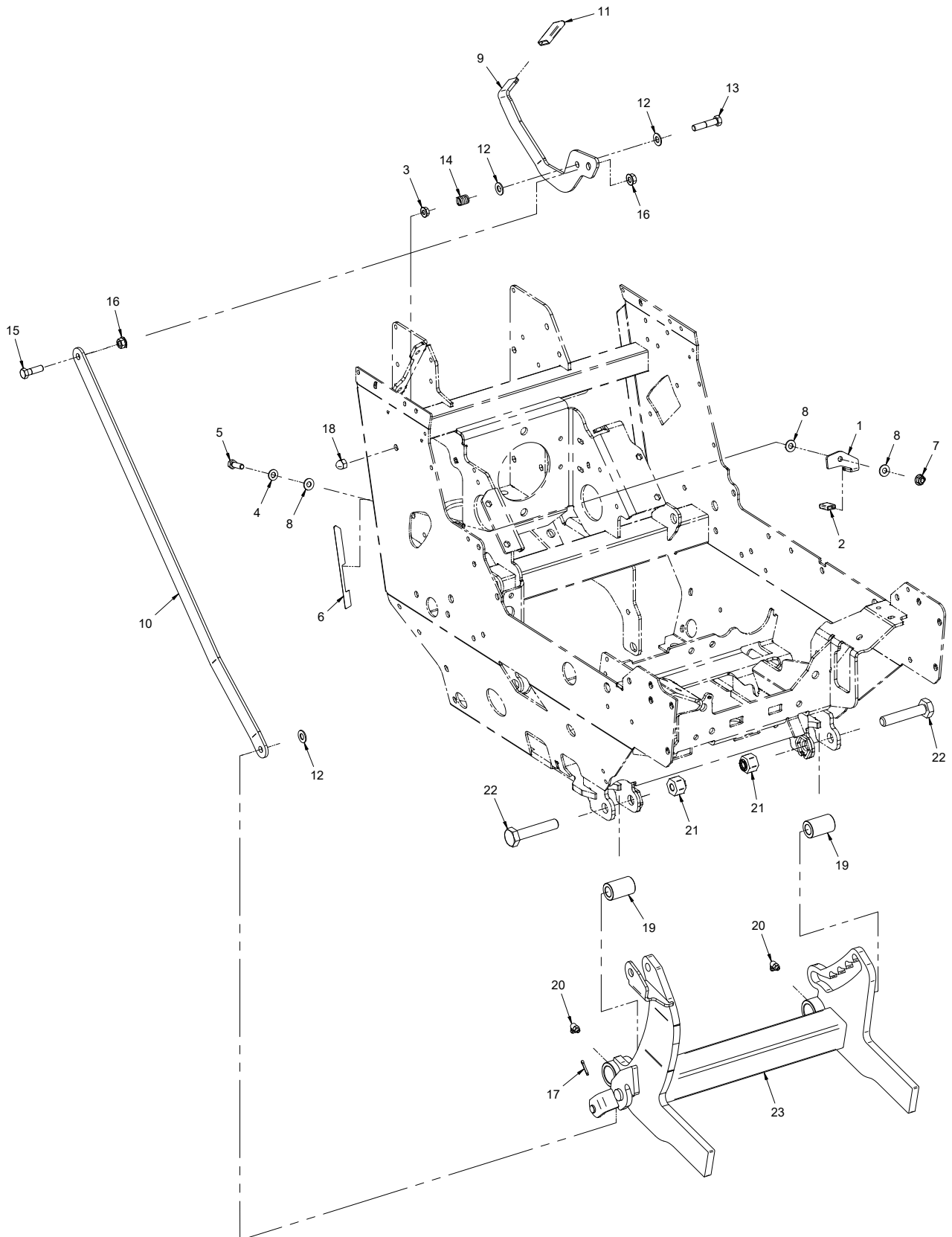

FRAMES / SHEET METAL

Front Hitch

REF.	PART NO.	DESCRIPTION	QTY.
1	64.1617	.LOCK, FRONT HITCH LEVER	1
2	06.0044	.CAP, PLASTIC 1/8 X 1/2 X 7/8	1
3	99.SF05	.NUT, SRF 5/16-18 USS	1
4	95.05	.WASHER, FLAT 5/16 SAE	1
5	90.0508	.BOLT, 5/16-18 USS X 1"	1
6	00.0317	.DECAL, FRONT HITCH LOCK	1
7	99.E0102	.NUT, LOCKING FLANGE 5/16-18	1
8	05.0055	.WASHER, NYLON .34 X .74 X .062	3
9	40.0376	.LEVER, FRONT HITCH LATCH	1
10	42.0558	.LINK, FRONT HITCH LATCH	1
11	06.0051	.CAP, 3/16 X 15/16 X 1-3/4 FE	1
12	95.06	.WASHER, FLAT 3/8 SAE	3
13	90.0614	.BOLT, HEX 3/8-16 UNC X 1-3/4	1
14	41.0039	.SPRING, COMP. 9/16 OD X 5/8	1
15	90.0610	.BOLT, 3/8-16 USS X 1-1/4	1
16	99.SF06	.NUT, SRF 3/8-16 USS	2
17	02.CP0406	.COTTER PIN, 1/8 X 3/4	1
18	99.E0100	.NUT, ACORN 3/8-16	1
19	64.1609	.BUSHING, FRONT HITCH PIVOT	2
20	29.GF0002	.GREASE FTG, 1/4 SAE 90	2
21	99.E0095	.LOCKNUT, 5/8-11 HEAVY NYLON	2
22	99.K0121	.BOLT, 5/8-11 X 3-1/4 GRD A325	2
23	62.1374	.FRAME, FRONT HITCH	1

FRAMES / SHEET METAL

ILLUSTRATED DRAWING Hood, Grill, & Headlights

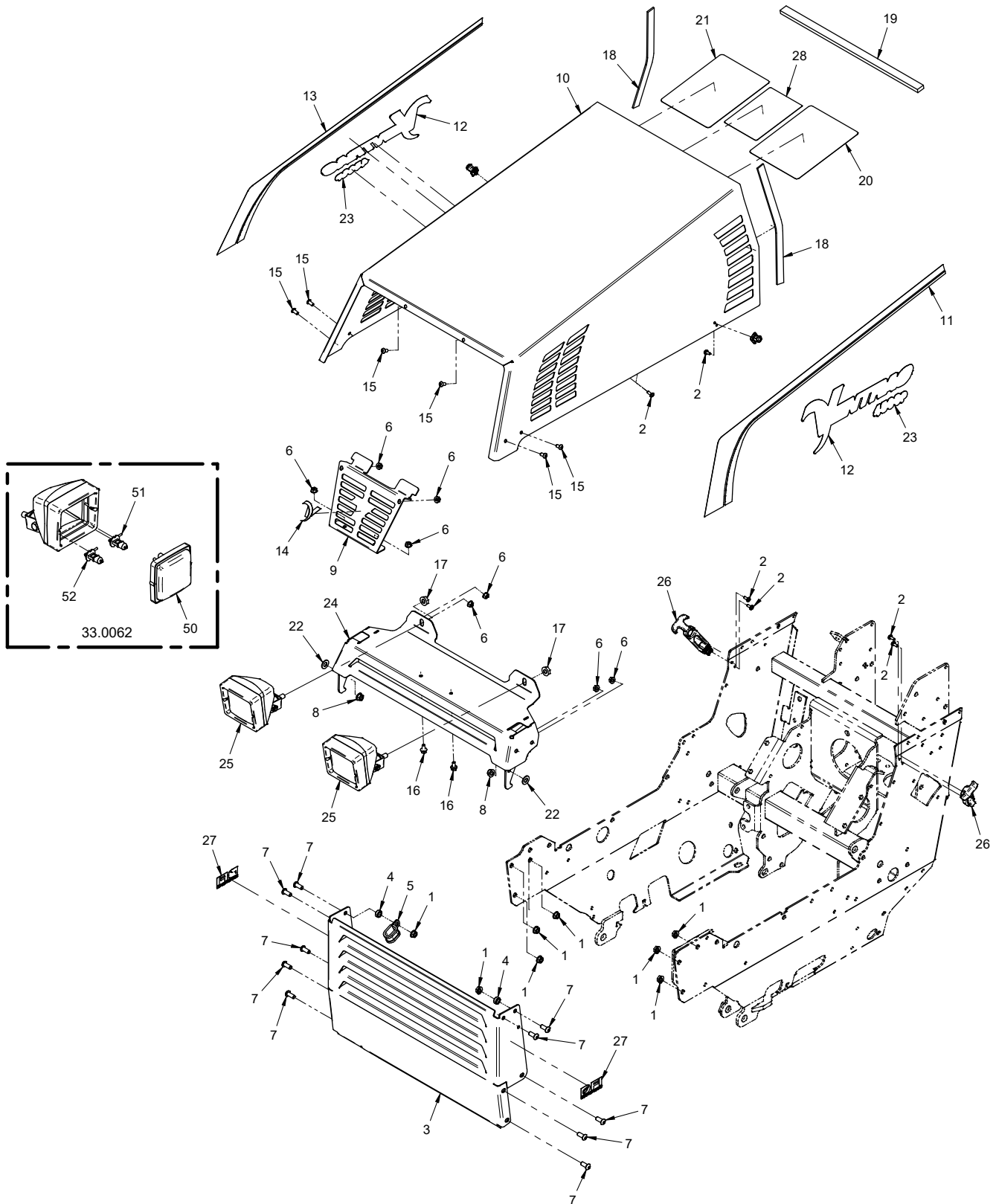

FRAMES / SHEET METAL

Hood, Grill, & Headlights

REF.	PART NO.	DESCRIPTION	QTY.
1	99.SF05	.NUT, SRF 5/16-18 USS	8
2	99.K0072	.MACHINE SCREW, 10-24 X 1/2 ZP	6
3	62.1372	.BUMPER, FRONT	1
4	64.0602	.BUSHING, 3/8 X 5/8 X .265	2
5	11.0046	.CLAMP, CUSHIONED METAL 1/2"	1
6	99.E0101	.NUT, LOCKING FLANGE 1/4-20	8
7	99.0506	.BOLT, 5/16-18 X 3/4 BSCS	10
8	99.E0102	.NUT, LOCKING FLANGE 5/16-18	2
9	60.1145	.GRILL, FRONT FILLER	1
10	60.1144	.HOOD, ENGINE 4500	1
11	00.0299	.DECAL, HOOD LEFT	1
12	00.0308	.DECAL, VENTRAC	2
13	00.0300	.DECAL, HOOD RIGHT	1
14	00.0326	.DECAL, "V" RAISED	1
15	99.0404	.BOLT, 1/4-20 X 1/2 BSCS	6
16	99.SF0404-1	.BOLT, SMF 1/4-20 X 1/2	2
17	99.M0021	.NUT, SMF M10 X 1.5	2
18	06.0045-12IN	.WEATHERSTRIP, 1/8 X 3/4 X 12"	2
19	06.0055-17IN	.WEATHERSTRIP, 3/8 X 3/4 X 17"	1
20	00.0307	.DECAL, MAINTENANCE	1
21	00.0337	.DECAL, QUICK REFERENCE 4500	1
22	05.0083	.WASHER, PVC .375ID X .875 X .0625	2
23	00.0310	.DECAL, 4500P	2
24	60.1143	.GRILL, FRONT (Serial # 01001-02490)	1
24	60.1253	.GRILL, FRONT (Serial # 02491-)	1
25	33.0062	.LIGHT, WORK 3 X 3	2
26	47.0127	.LATCH, RUBBER DRAW T-HANDLE	2
27	00.0321	.DECAL, DFI	2
28	00.0385	.DECAL, MAINTENANCE ENGINE OIL	1
50	33.0054	.OPTICAL UNIT, LENS/REFLECTOR	1
51	33.0055	.BULB, LIGHT (ONLY) FOR 55 WATT	1
52	33.0056	.BULB, LIGHT (ONLY) FOR 35 WATT (Optional)	1

FRAMES / SHEET METAL

ILLUSTRATED DRAWING Dash, Dash Brackets, Decals, & Switches

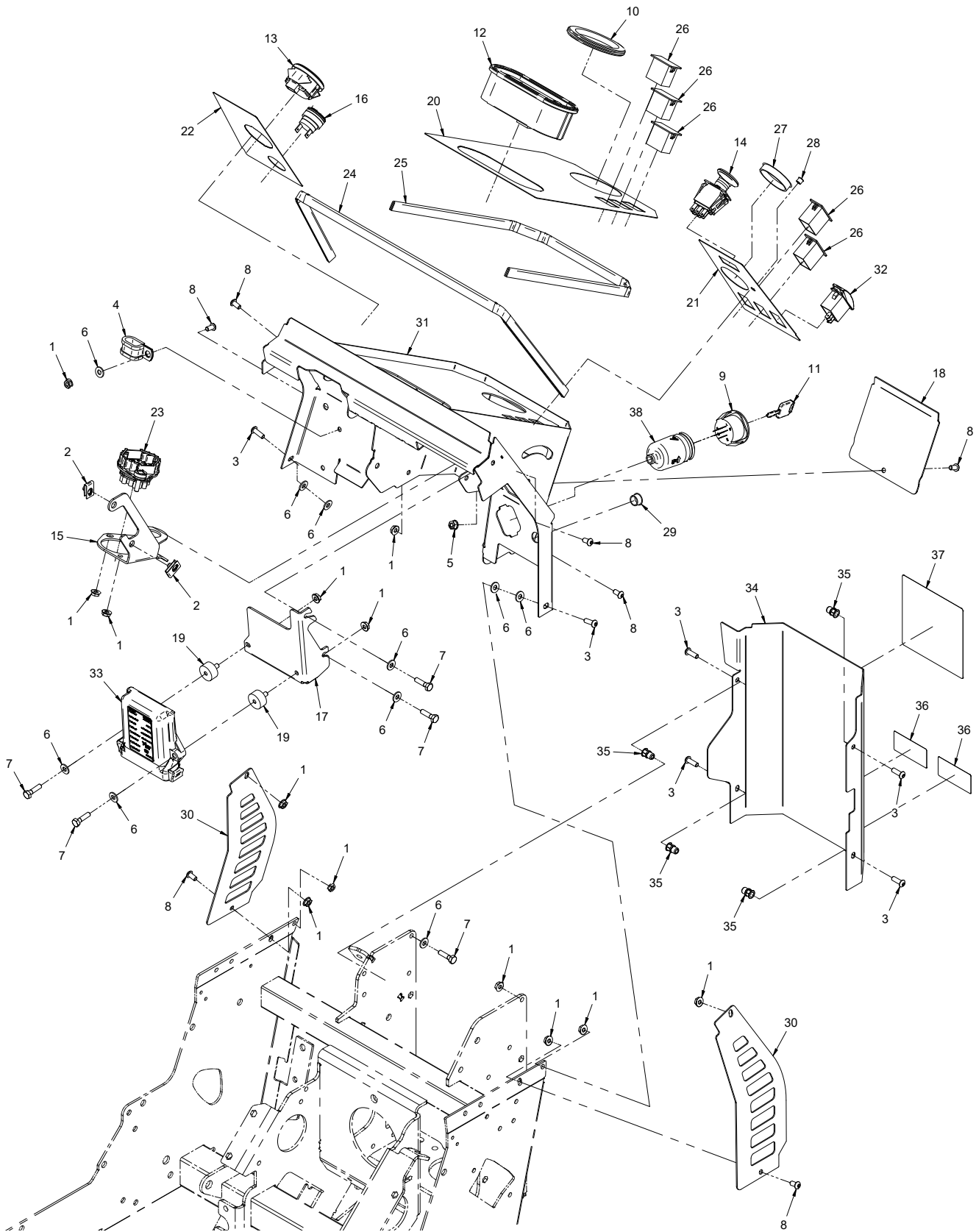

FRAMES / SHEET METAL

Dash, Dash Brackets, Decals, & Switches

REF.	PART NO.	DESCRIPTION	QTY.
1	99.SF04	.NUT, SRF 1/4-20 USS	13
2	99.E0046	.NUT, "U" 1/4-20 EXTRUDED	2
3	99.0406	.BOLT, 1/4-20 X 3/4 BSCS	6
4	11.0046	.CLAMP, CUSHIONED METAL 1/2"	1
5	99.E0101	.NUT, LOCKING FLANGE 1/4-20	1
6	95.04	.WASHER, FLAT 1/4 SAE	10
7	90.0408	.BOLT, 1/4-20 USS X 1"	5
8	99.0404	.BOLT, 1/4-20 X 1/2 BSCS	7
9	13.0078	.SWITCH, IGNITION DELTA	1
10	05.0080	.GROMMET, 2-3/4 ID, 3-5/8 OD, 5/16T	1
11	13.0080	.KEY, IGNITION DELTA	1
12	35.0147	.GAUGE, CLUSTER INFORMATION	1
13	35.0123	.GAUGE, CLUSTER WARNING	1
14	31.0043	.SWITCH, PTO - PUSH / PULL	1
15	64.1691	.BRACKET, HARNESS CONNECTOR	1
16	35.0124	.ALARM, AUDIBLE CONT. PANEL MT	1
17	64.1690	.BRACKET, TCM	1
18	60.1132	.COVER, STEERING VALVE	1
19	05.0135	.ISOLATOR, 1/4-20 X 1/2 X 1" F/M	2
20	00.0304	.DECAL, DASH CENTER	1
21	00.0303	.DECAL, DASH LEFT	1
22	00.0305	.DECAL, DASH RIGHT	1
23	30.0351	.CONNECTOR, TOWER 22 PIN SEAL	1
24	06.0042-33.5IN	.TRIM, TRIM LOC 1/2 X 1/16 X 33-1/2"	1
25	06.0042-34.88IN	.TRIM, TRIM LOC 1/2 X 1/16 X 34-7/8"	1
26	05.0131	.PLUG, SWITCH OTTO K5	5
27	05.0058	.PLUG, 2" HOLE, NYLON	1
28	05.0147	.PLUG, 5/16" HOLE, NYLON BLACK	1
29	05.0139	.PLUG, 5/8" HOLE, BLK PLASTIC	1
30	60.1141	.PANEL, DASH ACCESS	2
31	62.1376	.DASH, MAIN PANEL	1
32	31.0053	.SWITCH, ROCKER ON/OFF	1
33	35.0128	.MODULE, TRACTOR CONTROL (Serial # 01001-02478)	1
33	35.0146	.MODULE, TRACTOR CONTROL (Serial # 02479-04921)	1
33	35.0134	.MODULE, TRACTOR CONTROL (Serial # 04922)	1
34	60.1136	.COVER, PUMP	1
35	99.E0105	.NUT, INSERT 1/4-20 HEX	4
36	00.0342	.DECAL, WARNING PINCH POINT (Serial # 01001-14497)	2
36	00.0639	.DECAL, PINCHING HAZARD FOOT (Serial # 14498-)	2
37	00.0347	.DECAL, 4500 SLOPE WARNING (Serial # 01001-14497)	1
37	00.0642	.DECAL, SLOPE WARNING (Serial # 14498-)	1
38	30.0469	.COVER, SPLASHGUARD IG SWITCH (Serial # 03834-)	1

CONTROLS & LINKAGE

ILLUSTRATED DRAWING SDLA Control Levers

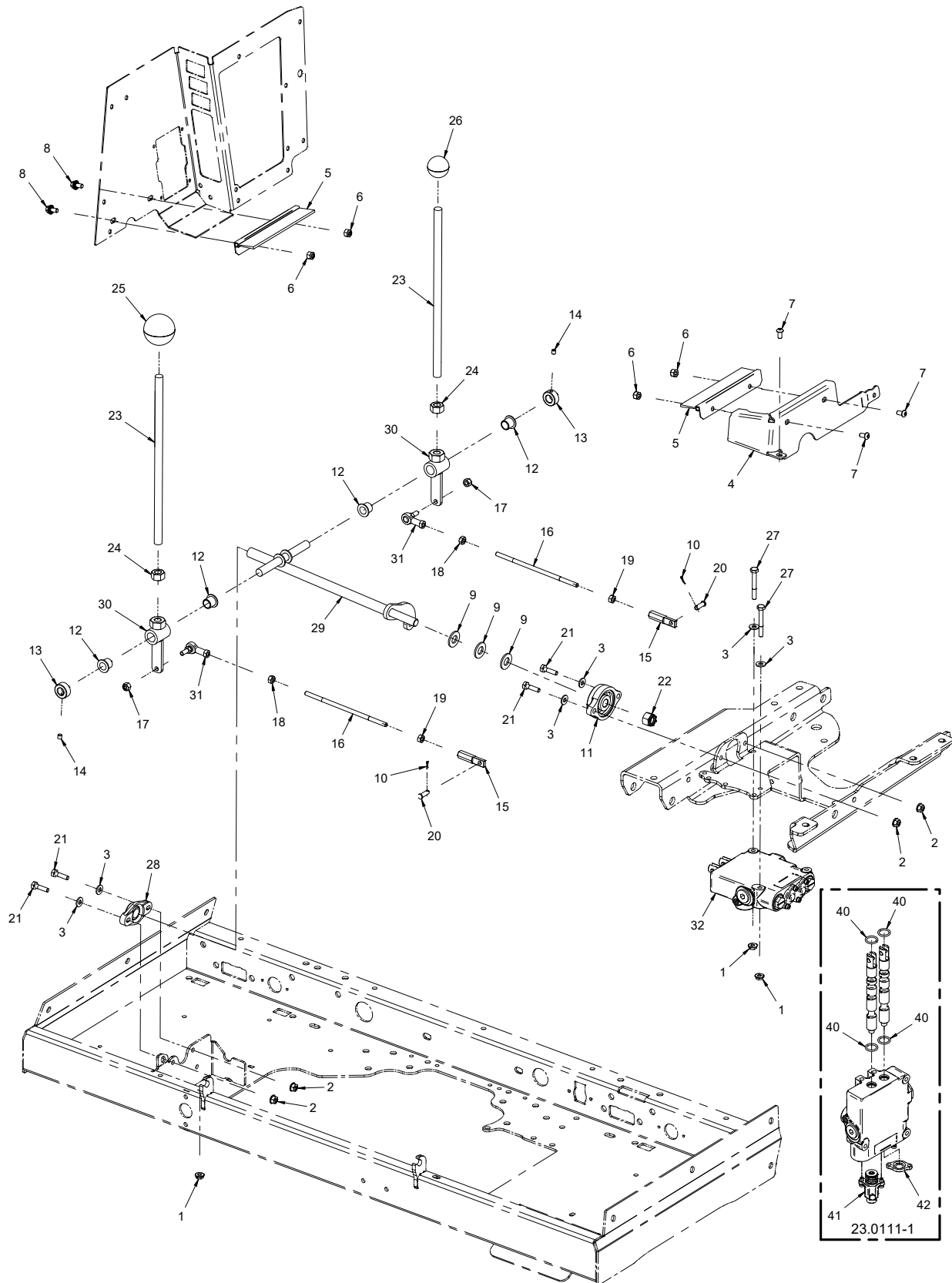

CONTROLS & LINKAGE

SDLA Control Levers

REF.	PART NO.	DESCRIPTION	QTY.
1	99.SF04	.NUT, SRF 1/4-20 USS	3
2	99.E0101	.NUT, LOCKING FLANGE 1/4-20	4
3	95.04	.WASHER, FLAT 1/4 SAE	6
4	60.1120	.COVER, SDLA PIVOT	1
5	79.0091	.BRUSH, SDLA COVER W/HOLDER	2
6	99.A04N	.LOCKNUT, NYLON 1/4-20	4
7	99.0404	.BOLT, 1/4-20 X 1/2 BSCS	3
8	99.SF0404	.BOLT, SRF 1/4-20 X 1/2	2
9	95.08	.WASHER, FLAT 1/2 SAE	3
10	02.CP0204	.COTTER PIN, 1/16 X 1/2	2
11	55.FB16008	.BEARING, FLANGE BLCK 1/2 ID	1
12	85.B0027	.BUSHING, 1/2 ID X 5/8 OD X 5/8	4
13	85.SC08	.SET COLLAR, 1/2"	2
14	85.SS19	.SET SCREW, 1/4-20 X 1/4"	2
15	43.004-4	.ROD END, 1/4-28LH YZP VAL CTRL	2
16	42.0563	.ROD, THREAD 1/4-28x7-1/2 RH/LH	2
17	99.A04NFN	.LOCKNUT, NYLON 1/4-28	2
18	93.04	.NUT, 1/4-28 SAE	2
19	99.E0081	.NUT, 1/4-28 LH GRADE 8 YZ	2
20	03.0406	.CLEVIS PIN, 1/4 X 3/4	2
21	90.0408	.BOLT, 1/4-20 USS X 1"	4
22	99.A08N	.LOCKNUT, NYLON 1/2-13 USS	1
23	40.0240	.HANDLE, F/R CONTROL	2
24	92.08	.NUT, 1/2-13 USS	2
25	47.0003	.KNOB, ROUND 2" X 1/2-13 THREAD	1
26	47.0329	.KNOB, ROUND 1-3/8 X 1/2-13	1
27	90.0416	.BOLT, 1/4-20 USS X 2"	2
28	55.0081	.BEARING, FLANGE IGUS 5/8"	1
29	40.0372	.ARM, SDLA PIVOT	1
30	42.0562	.PIVOT, SDLA LIFT LEVER	2
31	43.004S	.ROD END, 1/4 SPHERICAL W/STUD	2
32	23.0111-1	.VALVE, HY 2 SPL W/LH FLT, RH SP	1
40	26.0027	.O-RING, 5/8ID X 13/16OD X 3/32	4
41	23.0111-7	.KIT, SPOOL FLOAT HYD. VALVE	1
42	23.0111-8	.CAP, VALVE	1

CONTROLS & LINKAGE

ILLUSTRATED DRAWING SDLA Linkage

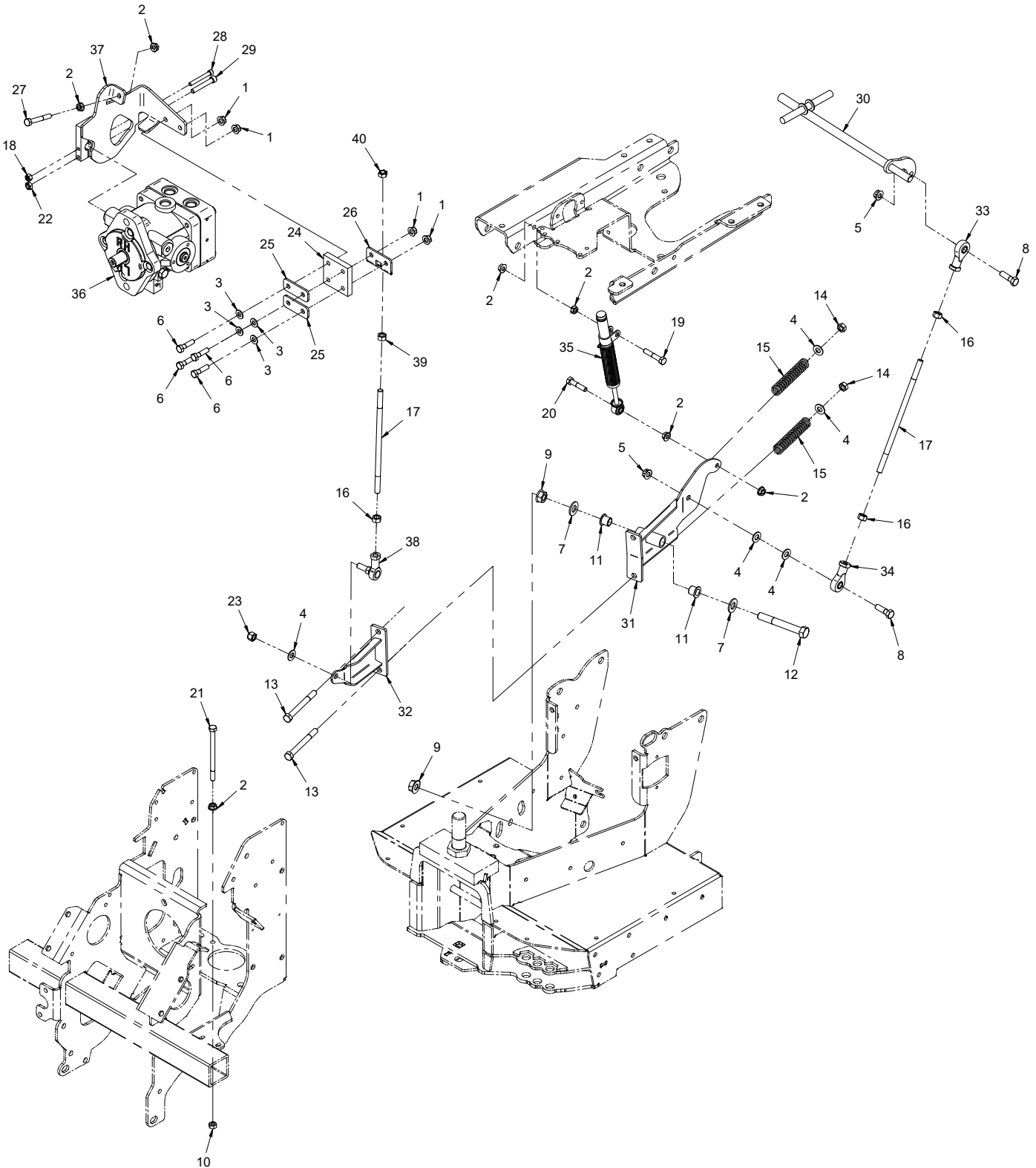

CONTROLS & LINKAGE

SDLA Linkage

REF.	PART NO.	DESCRIPTION	QTY.
1	99.E0102	.NUT, LOCKING FLANGE 5/16-18	4
2	99.SF05	.NUT, SRF 5/16-18 USS	7
3	95.05	.WASHER, FLAT 5/16 SAE	4
4	95.06	.WASHER, FLAT 3/8 SAE	5
5	99.E0082	.NUT, LOCKING FLANGE 3/8-16	2
6	90.0510	.BOLT, 5/16-18 USS X 1-1/4"	4
7	95.08	.WASHER, FLAT 1/2 SAE	2
8	90.0610	.BOLT, 3/8-16 USS X 1-1/4	2
9	99.SF08	.NUT, SRF 1/2-13 USS	2
10	92.05	.NUT, 5/16-18 USS	1
11	85.B0027	.BUSHING, 1/2 ID X 5/8 OD X 5/8	2
12	90.0830	.BOLT, 1/2-13 USS X 3-3/4	1
13	90.0628	.BOLT, 3/8-16 USS X 3-1/2	2
14	99.A06	.LOCKNUT, STOVER 3/8-16 USS	2
15	41.0063	.SPRING, COMP. 3/4 OD X 4" LG	2
16	93.06	.NUT, 3/8-24 SAE	3
17	42.0550	.ROD, THREAD 3/8-24 X 9" RH/LH ZP	2
18	99.A04NFN	.LOCKNUT, NYLON 1/4-28	1
19	90.0514	.BOLT, 5/16-18 USS X 1-3/4"	1
20	90.0512	.BOLT, 5/16-18 USS X 1-1/2"	1
21	90.0538-2	.BOLT, 5/16-18 X 4-3/4 ALL THRD	1
22	99.A05	.LOCKNUT, STOVER 5/16-18 USS	1
23	99.A06NFN	.LOCKNUT, NYLON 3/8-24 SAE ZP	1
24	44.0161	.LINK, RUBBER FOR SHIFT LINKAGE	1
25	64.0763	.CLAMP, RUBBER CONNECTOR	2
26	64.0764	.BRACKET, PUMP CONTROL LINK	1
27	90.0518	.BOLT, 5/16-18 USS X 2-1/4"	1
28	99.K0076	.BOLT, SHCS 1/4-28 X 2 GRADE 8	1
29	99.K0123	.BOLT, SHCS 5/16-18 X 2 GRADE 8	1
30	40.0372	.ARM, SDLA PIVOT	1
31	40.0371	.ARM, ROCKER F/R REAR	1
32	40.0370	.ARM, ROCKER F/R FRONT	1
33	43.006	.ROD END, 3/8 SPHERICAL, FEMALE	1
34	43.006L	.ROD END, 3/8 SPHERICAL, LH THRD	1
35	47.0316	.DAMPER, 3.187 STROKE GAS SHOCK	1
36	21.0080	.PUMP, HYD. CCW 1000 PSI	1
37	40.0375	.ARM, CONTROL/SWASH PLATE	1
38	43.006S	.ROD END, 3/8 SPHERICAL W/ STUD	1
39	99.E0114	.NUT, 3/8-24 LH ZP	1
40	99.E0107	.LOCKNUT, 3/8-24 LH ZP	1

CONTROLS & LINKAGE

ILLUSTRATED DRAWING Neutral Assist Lever & Neutral Switch

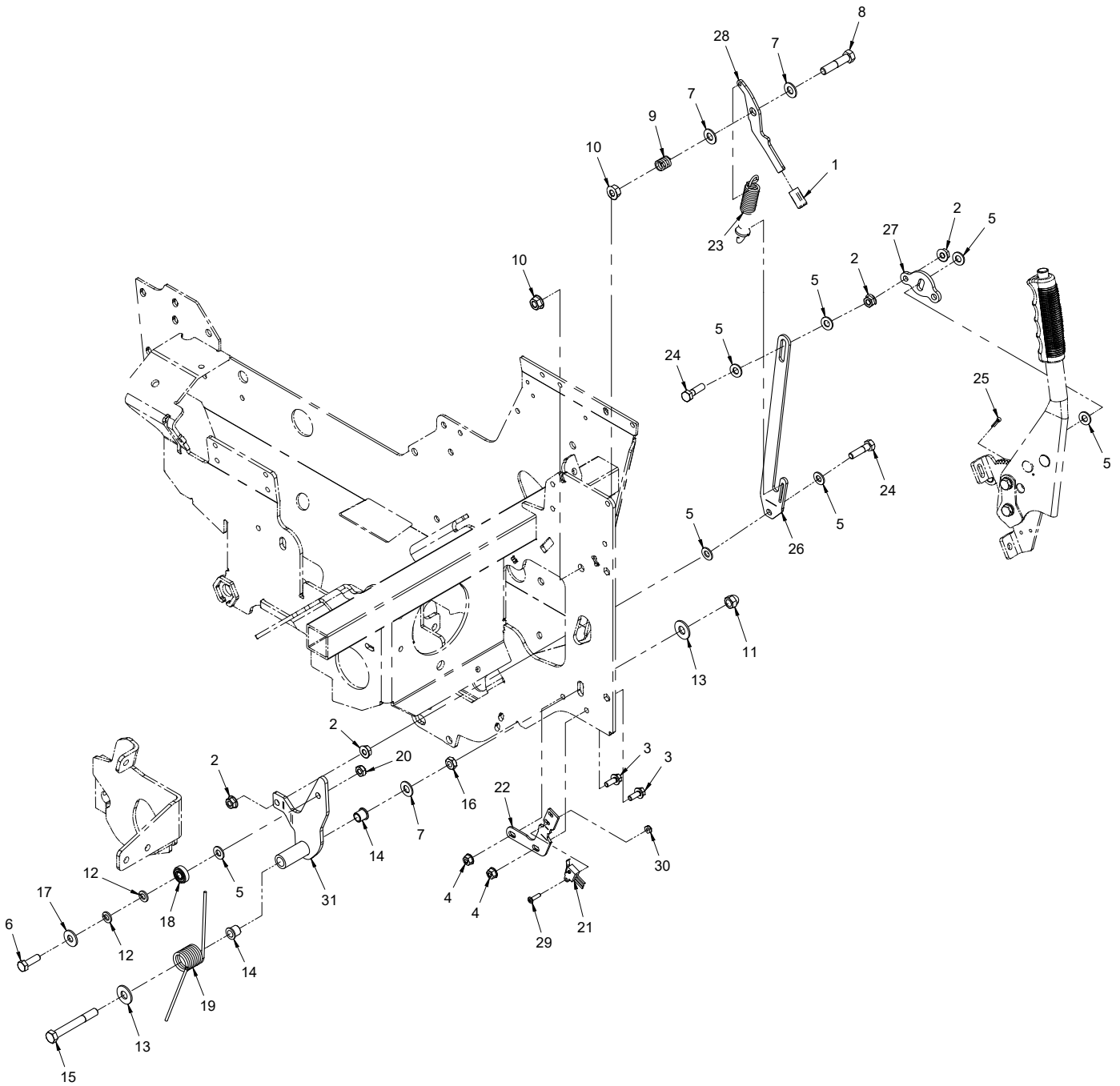

CONTROLS & LINKAGE

Neutral Assist Lever & Neutral Switch

REF.	PART NO.	DESCRIPTION	QTY.
1	06.0044	.CAP, PLASTIC 1/8 X 1/2 X 7/8	1
2	99.SF05	.NUT, SRF 5/16-18 USS	4
3	99.SF0405-1	.BOLT, SMF 1/4-20 X 5/8	2
4	99.E0101	.NUT, LOCKING FLANGE 1/4-20	2
5	95.05	.WASHER, FLAT 5/16 SAE	7
6	90.0508	.BOLT, 5/16-18 USS X 1"	1
7	95.06	.WASHER, FLAT 3/8 SAE	3
8	90.0614	.BOLT, 3/8-16 USS X 1-3/4	1
9	41.0039	.SPRING, COMP. 9/16 OD X 5/8	1
10	99.SF06	.NUT, SRF 3/8-16 USS	2
11	99.E0100	.NUT, ACORN 3/8-16	1
12	96.05	.WASHER, LOCK 5/16	2
13	94.06	.WASHER, FLAT 3/8 USS	2
14	85.B0068	.BUSHING, 3/8 X 1/2 OD X 1/2 LG	2
15	90.0624	.BOLT, 3/8-16 USS X 3	1
16	99.E0037	.NUT, JAM 3/8-16 USS	1
17	94.05	.WASHER, FLAT 5/16 USS	1
18	55.0022	.BEARING, BALL .315 ID X .8661 OD	1
19	41.0105	.SPRING, TORSION LH .83"ID SS	1
20	99.E0109	.NUT, JAM 5/16-18 NYLON LOCK	1
21	31.0058-2	.SWITCH, MICRO NEUTRAL	1
22	64.1652	.BRACKET, NEUTRAL SWITCH MOUNT	1
23	41.0106	.SPRING, EXT 3/4 OD X 4 LG	1
24	90.0510	.BOLT, 5/16-18 USS X 1-1/4"	2
25	02.CP0404	.COTTER PIN, 1/8 X 1/2	1
26	42.0556	.LINK, NEUTRAL ASSIST	1
27	64.1626	.ROCKER, PARK BRAKE TENSIONER	1
28	40.0374	.LEVER, NEUTRAL ASSIST	1
29	99.K0133	.MACHINE SCREW, #8-32 X 5/8	1
30	99.E0104	.NUT, JAM #8-32 NYLON LOCK	1
31	64.1628	.ROCKER, NEUTRAL ASSIST	1

CONTROLS & LINKAGE

ILLUSTRATED DRAWING Parking Brake Handle, Brake Rod, & Shields

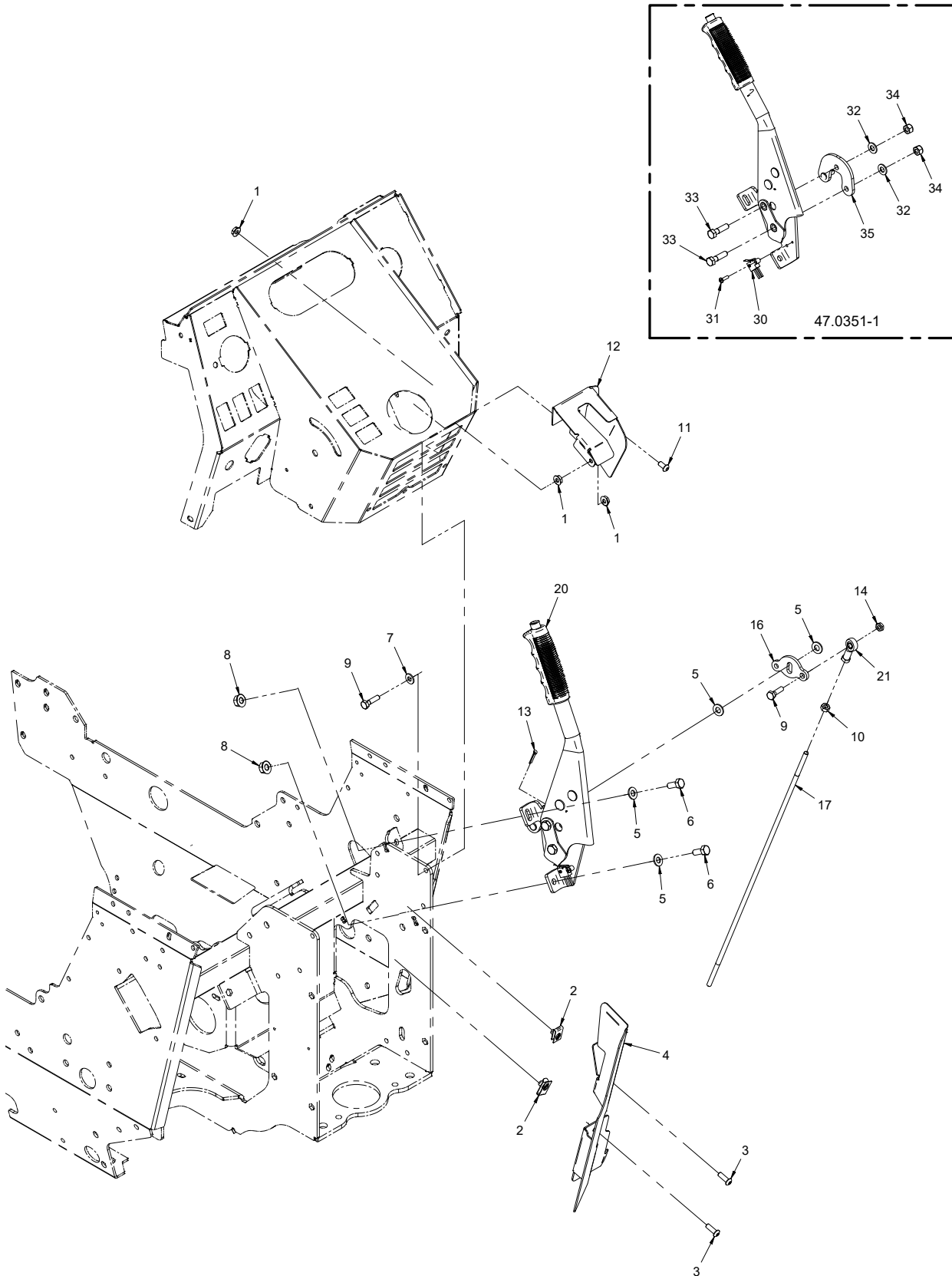

CONTROLS & LINKAGE

Parking Brake Handle, Brake Rod, & Shields

REF.	PART NO.	DESCRIPTION	QTY.
1	99.SF04	.NUT, SRF 1/4-20 USS	3
2	99.E0046	.NUT, "U" 1/4-20 EXTRUDED	2
3	99.0406	.BOLT, 1/4-20 X 3/4 BSCS	2
4	60.1151	.COVER, PUMP ACCESS RIGHT	1
5	95.05	.WASHER, FLAT 5/16 SAE	4
6	90.0506	.BOLT, 5/16-18 USS X 3/4"	2
7	95.04	.WASHER, FLAT 1/4 SAE	1
8	99.SF05	.NUT, SRF 5/16-18 USS	2
9	90.0408	.BOLT, 1/4-20 USS X 1"	2
10	99.E0081	.NUT, 1/4-28 LH GRADE 8 YZ	1
11	99.0404	.BOLT, 1/4-20 X 1/2 BSCS	1
12	60.1142	.COVER, PARKING BRAKE	1
13	02.CP0406	.COTTER PIN, 1/8 X 3/4	1
14	99.A04	.LOCKNUT, STOVER 1/4-20 USS	1
16	64.1626	.ROCKER, PARK BRAKE TENSIONER	1
17	42.0551	.ROD, THREAD 1/4-28 X 20" RH/LH	1
20	47.0351-1	.LEVER, PARKING BRAKE	1
21	43.004L	.ROD END, 1/4 SPHERICAL LH	1
30	31.0058-1	.SWITCH, MICRO PARKING BRAKE	1
31	99.M0033	.MACHINE SCREW, M4-0.7 X 14MM	1
32	95.05	.WASHER, FLAT 5/16 SAE	2
33	91.0510	.BOLT, 5/16-24 SAE X 1-1/4	2
34	99.A05NFN	.LOCKNUT, NYLON 5/16-24 SAE ZP	2
35	64.1633	.MOUNT, PARK BRAKE ROCKER	1

CONTROLS & LINKAGE

ILLUSTRATED DRAWING Parking Brake Linkage & Brake Drum

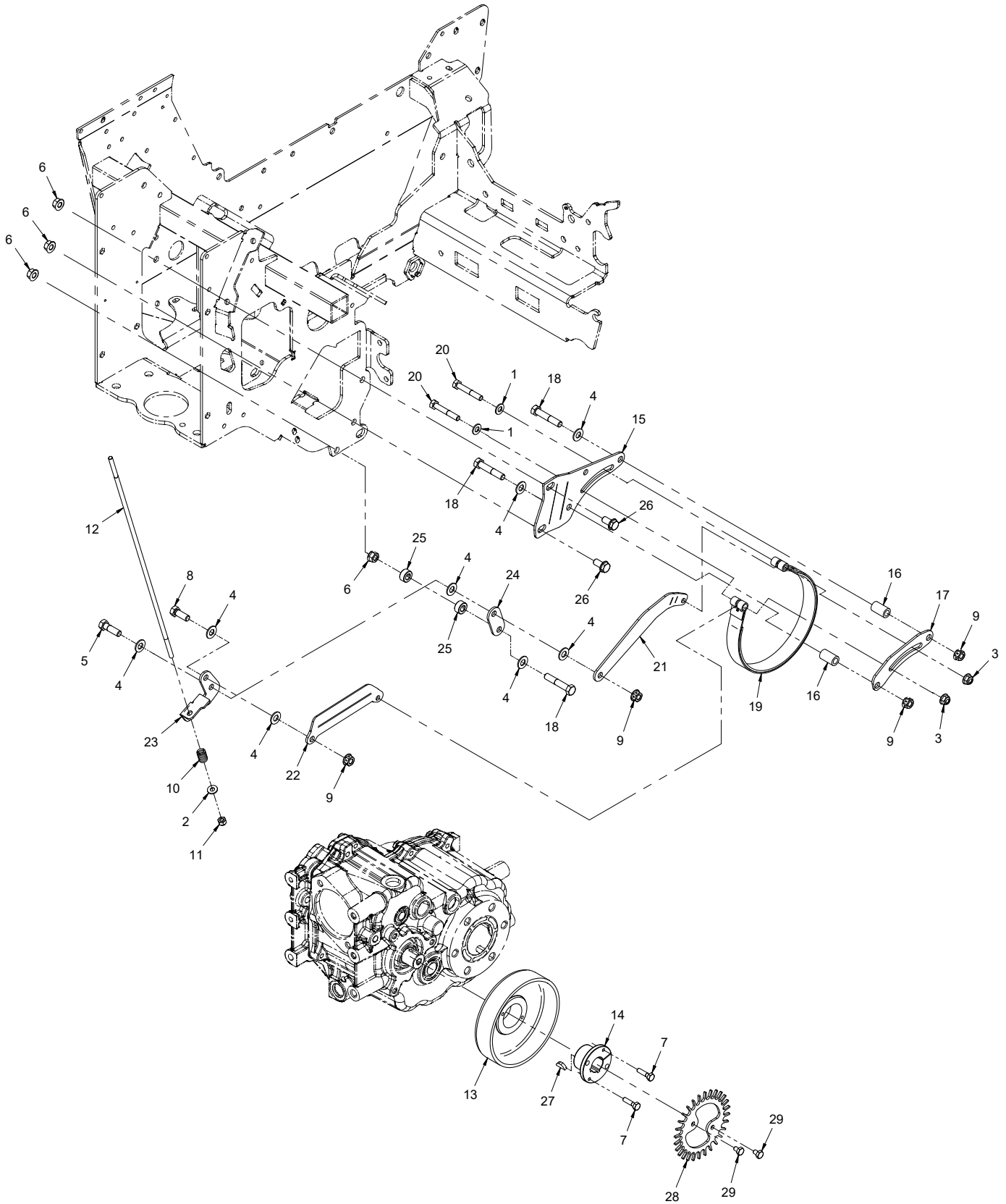

CONTROLS & LINKAGE

Parking Brake Linkage & Brake Drum

REF.	PART NO.	DESCRIPTION	QTY.
1	95.05	.WASHER, FLAT 5/16 SAE	2
2	95.04	.WASHER, FLAT 1/4 SAE	1
3	99.E0102	.NUT, LOCKING FLANGE 5/16-18	2
4	95.06	.WASHER, FLAT 3/8 SAE	8
5	90.0610	.BOLT, 3/8-16 USS X 1-1/4	1
6	99.SF06	.NUT, SRF 3/8-16 USS	4
7	90.0408	.BOLT, 1/4-20 USS X 1	2
8	90.0608	.BOLT, 3/8-16 USS X 1	1
9	99.E0082	.NUT, LOCKING FLANGE 3/8-16	4
10	41.0108	.SPRING, COMP. .531 OD X .780 LG	1
11	99.A04NFN	.LOCKNUT, NYLON 1/4-28	1
12	42.0551	.ROD, THREAD 1/4-28 X 20" RH/LH	1
13	53.0134	.DRUM, 6" BRAKE - W/TAPER HUB	1
14	83.H16S-2	.BUSHING, 1" SPLIT 3/16 * & 1/4 KEY	1
15	64.1614	.PLATE, BRAKE ANCHOR INNER	1
16	64.0718	.TUBE, RD .385 X 5/8 X 1-1/16L	2
17	64.0920	.PLATE, PARK BK MOUNT ALIGNMENT	1
18	90.0616	.BOLT, 3/8-16 USS X 2	3
19	53.0076	.BAND, BRAKE FOR 6" DRUM	1
20	90.0516	.BOLT, 5/16-18 USS X 2"	2
21	42.0441	.LINK, PARK BK PULL	1
22	42.0442	.LINK, PARK BK PUSH	1
23	64.1603	.ROCKER, PARK BRAKE	1
24	42.0443	.LINK, PARK BK TORQUE	1
25	85.SC06	.SET COLLAR, 3/8"	2
26	99.SF0606	.BOLT, FLANGE 3/8-16 UNC X 3/4	2
27	85.W0306	.KEY, WOODRUFF 3/16 X 3/4	1
28	64.1606	.PLATE, SPEED INDICATOR	1
29	90.0403	.BOLT, 1/4-20 USS X 3/8	2

CONTROLS & LINKAGE

ILLUSTRATED DRAWING High/Low Range Shift Linkage

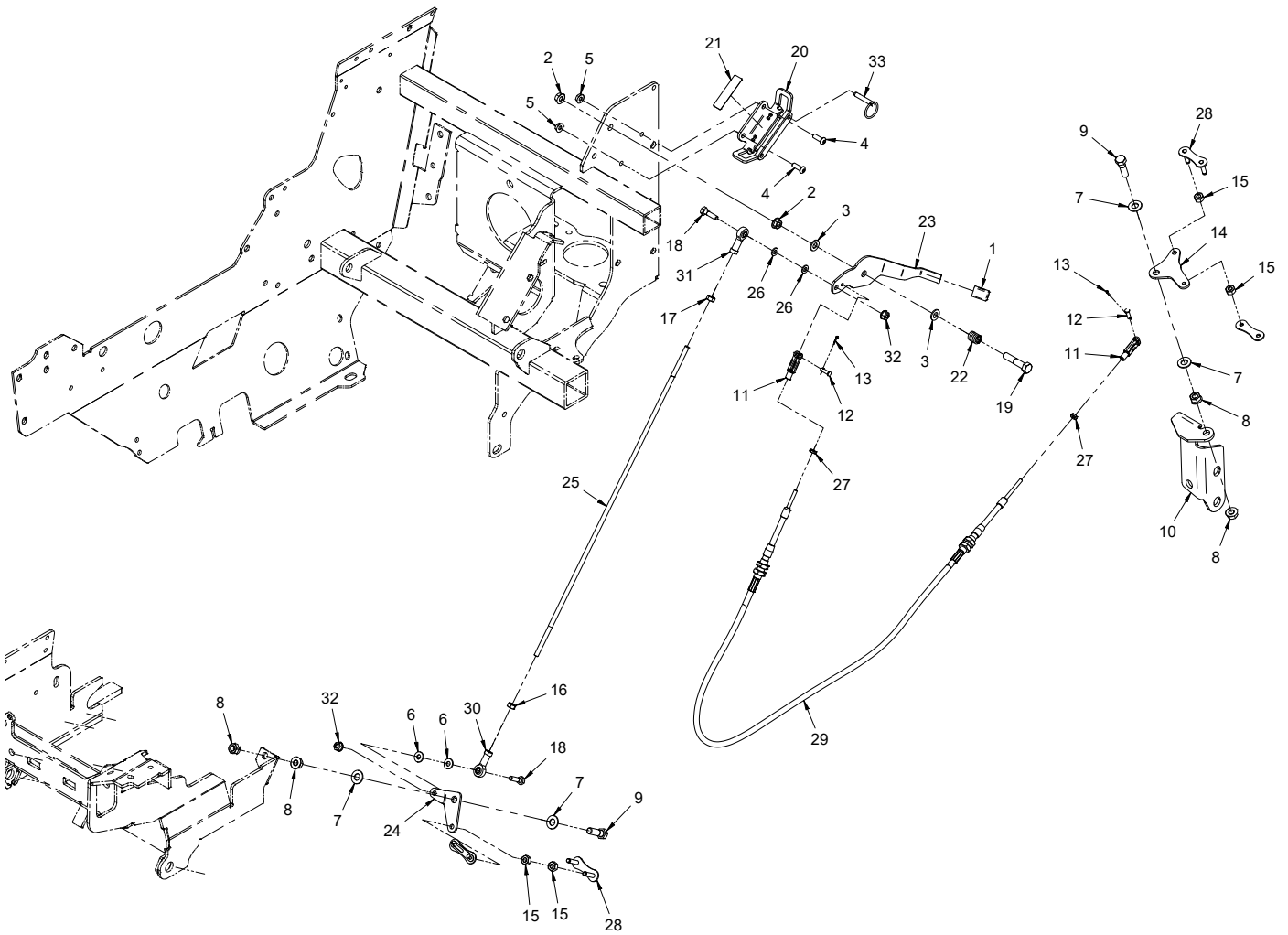

CONTROLS & LINKAGE

High/Low Range Shift Linkage

REF.	PART NO.	DESCRIPTION	QTY.
1	06.0044	.CAP, PLASTIC 1/8 X 1/2 X 7/8	1
2	99.SF05	.NUT, SRF 5/16-18 USS	2
3	95.05	.WASHER, FLAT 5/16 SAE	2
4	99.0406	.BOLT, 1/4-20 X 3/4 BSCS	2
5	99.SF04	.NUT, SRF 1/4-20 USS	2
6	95.04	.WASHER, FLAT 1/4 SAE	2
7	95.06	.WASHER, FLAT 3/8 SAE	4
8	99.SF06	.NUT, SRF 3/8-16 USS	4
9	90.0610	.BOLT, 3/8-16 USS X 1-1/4	2
10	64.1591	.BRACKET, REAR HITCH MT RIGHT	1
11	43.C10-32	.CLEVIS END, #10-32 3/16 HOLE	2
12	03.0305	.CLEVIS PIN, 3/16 X 5/8 ZP	2
13	02.CP0204	.COTTER PIN, 1/16 X 1/2	2
14	40.0373	.ARM, HIGH/LOW SHIFT ROCKER	1
15	92.05	.NUT, 5/16-18 USS	4
16	93.04	.NUT, 1/4-28 SAE	1
17	99.E0081	.NUT, 1/4-28 LH GRADE 8 YZ	1
18	90.0408	.BOLT, 1/4-20 USS X 1"	2
19	90.0614	.BOLT, 3/8-16 USS X 1-3/4	1
20	64.1618	.BRACKET, HIGH/LOW SHIFT SELECT (Serial # 01001-01745)	1
20	64.1784	.BRACKET, HIGH/LOW SHIFT LOCK (Serial # 01746-)	1
21	00.0313	.DECAL, HIGH/LOW RANGE	1
22	41.0039	.SPRING, COMP. 9/16 OD X 5/8	1
23	40.0379	.LEVER, HIGH/LOW SHIFT	1
24	64.0703	.PLATE, FRONT SHIFT PIVOT	1
25	42.0561	.ROD, THREAD 1/4-28X21.00 RH/LH	1
26	99.B0109	.WASHER, 1/4ID, .50 OD X .062T	2
27	99.E0034	.NUT, #10-32	2
28	81.0124	.LINK, CONN #60 DOUBLE PITCH	2
29	47.0122	.CABLE, HI-LOW SHIFT	1
30	43.004	.ROD END, 1/4 SPHERICAL	1
31	43.004L	.ROD END, 1/4 SPHERICAL LH	1
32	99.E0101	.NUT, LOCKING FLANGE 1/4-20	2
33	03.0022	.PIN, BALL 1/4" X 1" (Serial # 01746-)	1

CONTROLS & LINKAGE

ILLUSTRATED DRAWING PTO Idler Pulley & Idler Arm

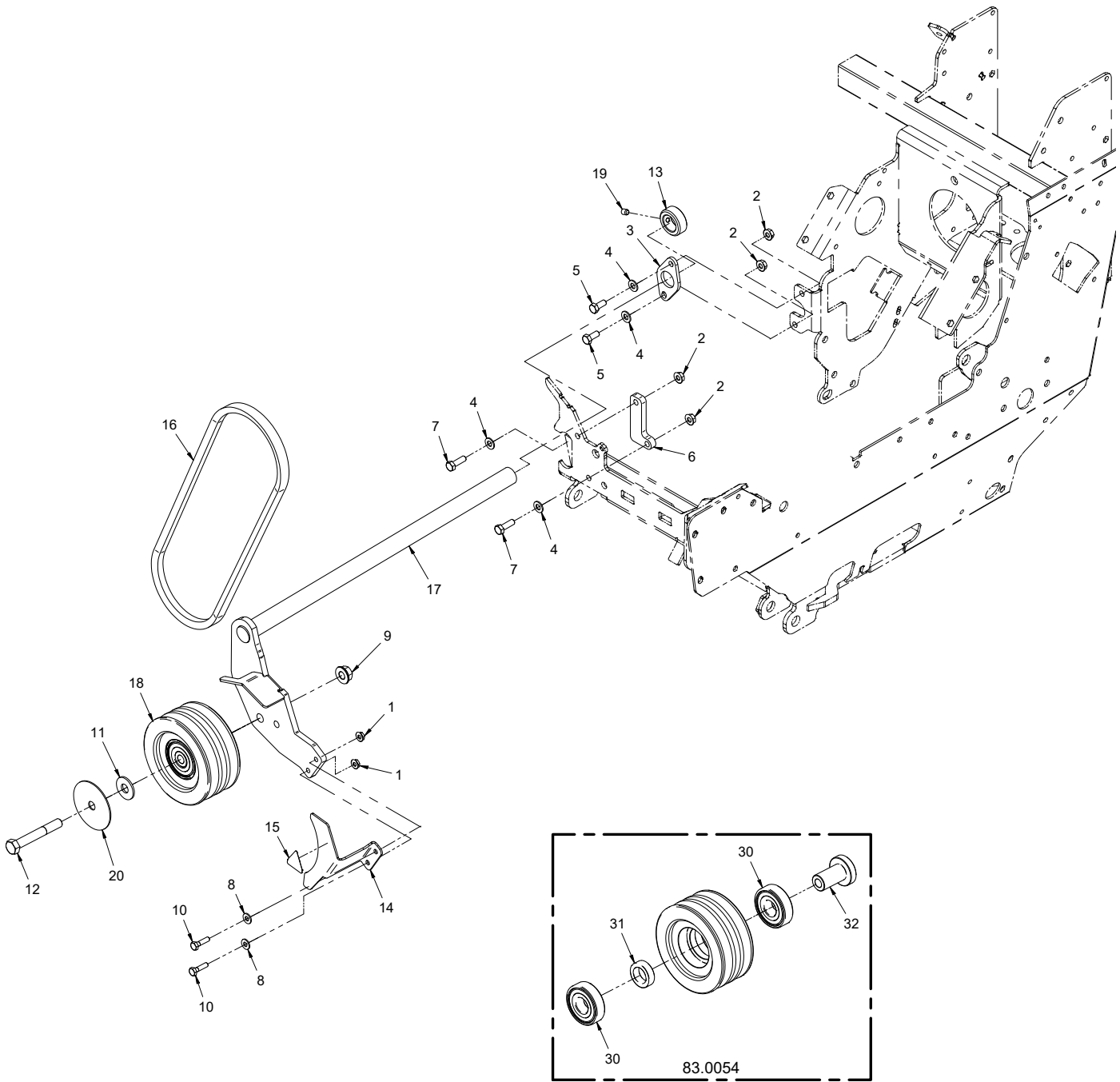

CONTROLS & LINKAGE

PTO Idler Pulley & Idler Arm

REF.	PART NO.	DESCRIPTION	QTY.
1	99.SF04	.NUT, SRF 1/4-20 USS	2
2	99.SF05	.NUT, SRF 5/16-18 USS	4
3	64.1702	.PLATE, PTO ARM HANGER	1
4	95.05	.WASHER, FLAT 5/16 SAE	4
5	90.0506	.BOLT, HEX 5/16-18 UNC X 3/4"	2
6	64.1699	.PLATE, PTO WEARBAR	1
7	90.0508	.BOLT, 5/16-18 USS X 1"	2
8	95.04	.WASHER, FLAT 1/4 SAE	2
9	99.E0103	.NUT, LOCKING FLANGE 1/2-13	1
10	90.0408	.BOLT, 1/4-20 USS X 1"	2
11	94.08	.WASHER, FLAT 1/2 USS	1
12	90.0828	.BOLT, 1/2-13 USS X 3-1/2	1
13	85.SC16-1	.SET COLLAR, 1.015"	1
14	60.1135	.GUARD, PTO IDLER PULLEY	1
15	00.0339	.DECAL, MOVING PARTS	1
16	81.B038	.BELT, B38	1
17	40.0378	.ARM, PTO IDLER	1
18	83.0054	.PULLEY, IDLER 2 GROOVE ASM	1
19	85.SS18	.SET SCREW, 5/16-18 X 3/8	1
20	60.1279	.COVER, PULLEY (Serial # 04776-)	1
30	55.0064	.BEARING, BALL 25 MM X 62 MM	2
31	85.B0085	.BUSHING, BEARING SPACER	1
32	85.B0084	.BUSHING, DRIVE PULLEY	1

CONTROLS & LINKAGE

ILLUSTRATED DRAWING PTO Belt Tension Linkage

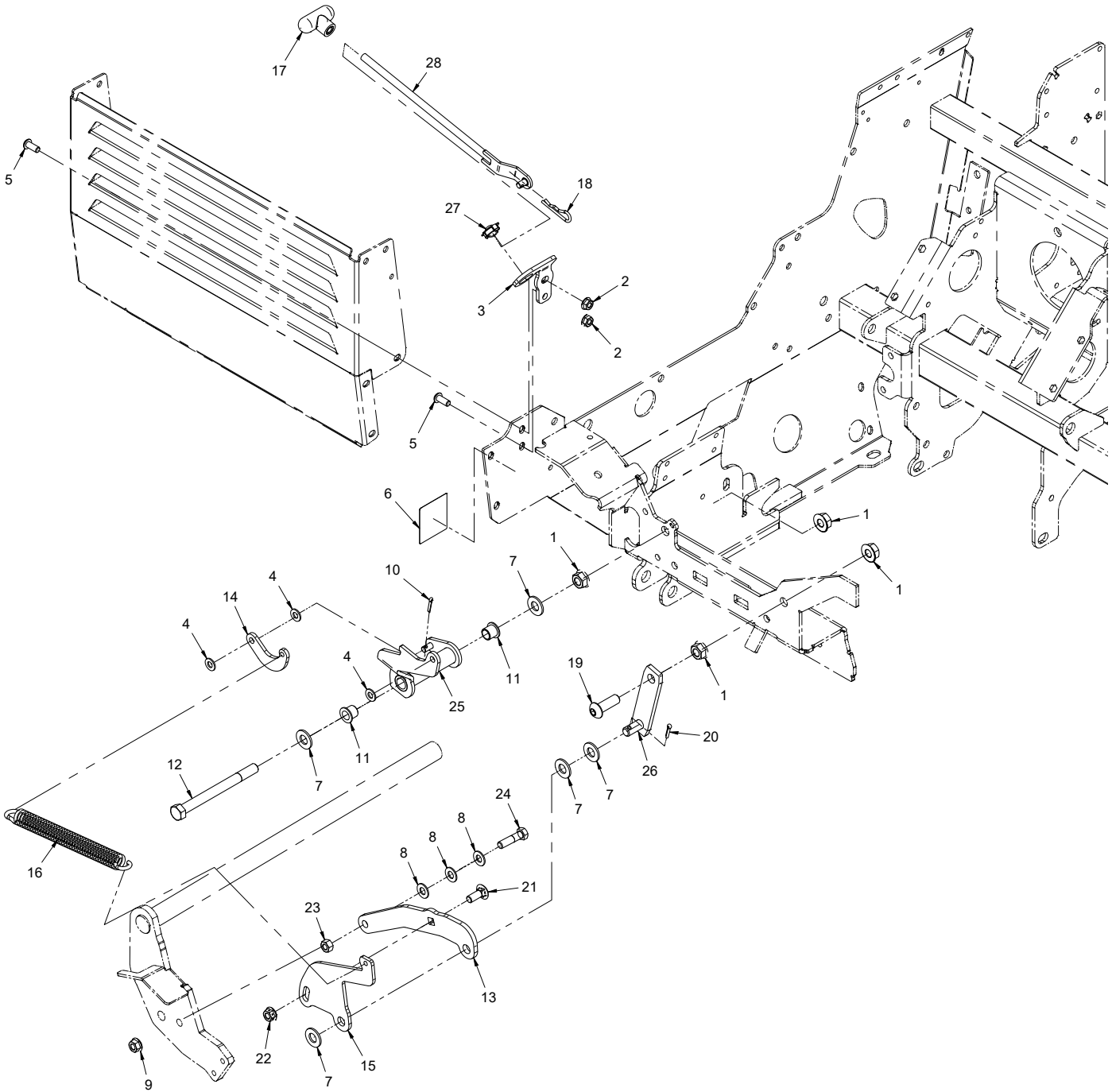

CONTROLS & LINKAGE

PTO Belt Tension Linkage

REF.	PART NO.	DESCRIPTION	QTY.
1	99.SF08	.NUT, SRF 1/2-13 USS.	4
2	99.SF05	.NUT, SRF 5/16-18 USS.	2
3	64.1616	.BRACKET, BELT RELEASE PIVOT	1
4	95.05	.WASHER, FLAT 5/16 SAE	3
5	99.0506	.BOLT, 5/16-18 X 3/4 BSCS.	2
6	00.0319	.DECAL, PTO TENSION	1
7	95.08	.WASHER, FLAT 1/2 SAE	5
8	95.06	.WASHER, FLAT 3/8 SAE	3
9	99.SF06	.NUT, SRF 3/8-16 USS.	1
10	02.CP0406	.COTTER PIN, 1/8 X 3/4	1
11	85.B0027	.BUSHING, 1/2 ID X 5/8 OD X 5/8.	2
12	90.0844	.BOLT, 1/2-13 USS X 5-1/2.	1
13	42.0552	.LINK, PTO IDLER PUSH ARM (Serial # 01001-05178).	1
13	42.0584	.LINK, PTO IDLER PUSH ARM (Serial # 05179-).	1
14	42.0557	.LINK, PTO BELT TENSIONER	1
15	42.0559	.LINK, PTO TENSIONER ADJUSTER	1
16	41.0056	.SPRING, EXT 7/8 OD X 8-1/2 LNG	1
17	47.0330	.KNOB, BAR 2-1/4 X 3/8-16.	1
18	02.HP0416	.HAIRPIN, 1/8 X 2.	1
19	99.0812	.BOLT, 1/2-13 X 1-1/2 BSCS	1
20	02.CP0506	.COTTER PIN, 5/32 X 3/4	1
21	90.0608	.BOLT, 3/8-16 USS X 1 (Serial # 01001-05178).	1
21	97.0608	.BOLT, CARRIAGE 3/8 X 1 (Serial # 05179-)	1
22	99.E0082	.NUT, LOCKING FLANGE 3/8-16	1
23	92.06	.NUT, 3/8-16 USS	1
24	90.0612	.BOLT, 3/8-16 USS X 1-1/2.	1
25	64.1627	.ROCKER, PTO IDLER ARM TENSION.	1
26	64.1610	.ROCKER, PTO TENSIONER.	1
27	55.0082	.BEARING, SPHERICAL 10MM ID	1
28	42.0554	.ROD, PTO BELT TENSIONER	1

CONTROLS & LINKAGE

ILLUSTRATED DRAWING Weight Transfer

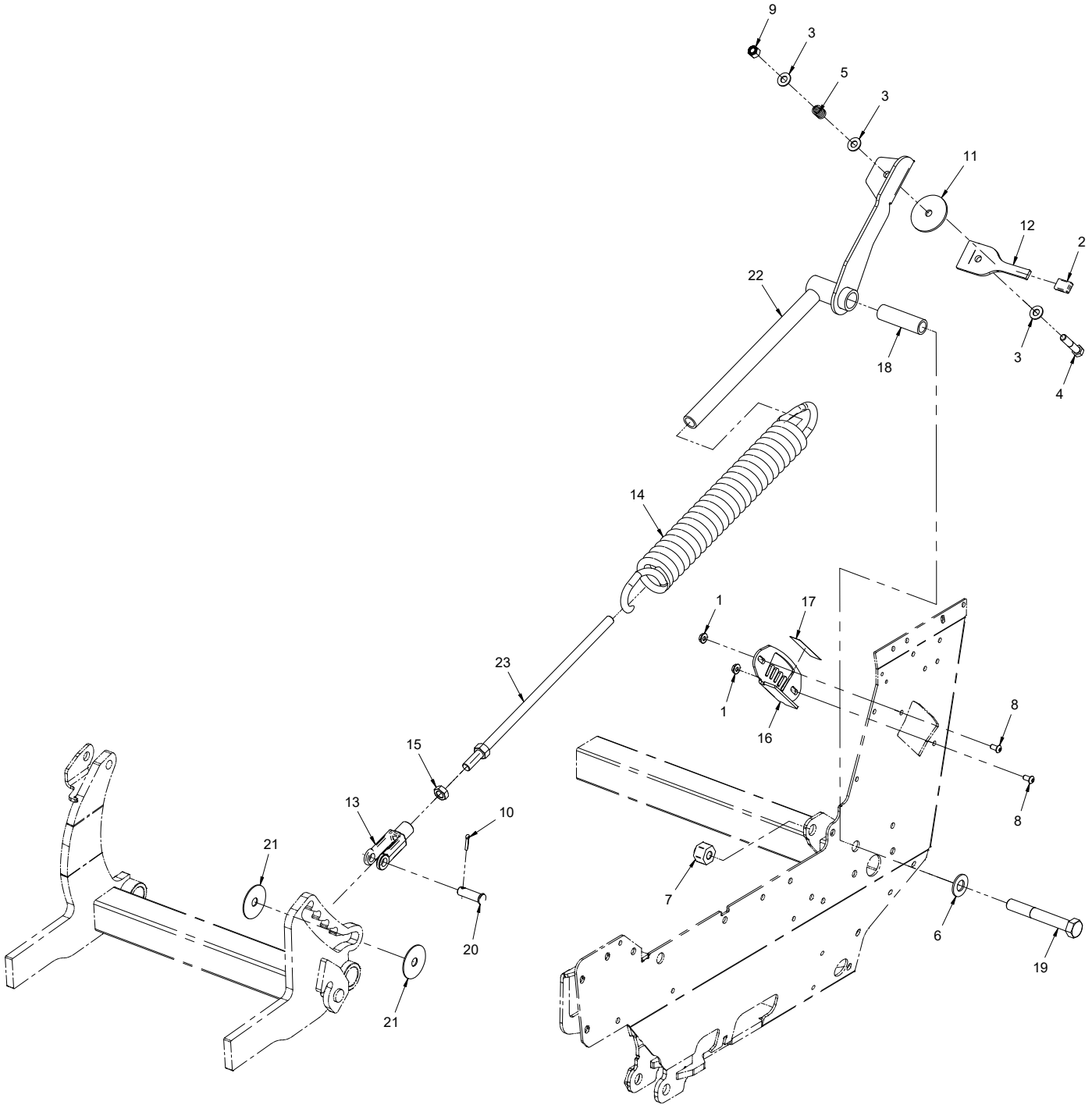

CONTROLS & LINKAGE

Weight Transfer

REF.	PART NO.	DESCRIPTION	QTY.
1	99.SF04	.NUT, SRF 1/4-20 USS.	2
2	06.0044	.CAP, PLASTIC 1/8 X 1/2 X 7/8	1
3	95.06	.WASHER, FLAT 3/8 SAE	3
4	90.0614	.BOLT, 3/8-16 USS X 1-3/4	1
5	41.0039	.SPRING, COMP. 9/16 OD X 5/8	1
6	95.10	.WASHER, FLAT 5/8 SAE	1
7	99.E0095	.LOCKNUT, 5/8-11 HEAVY NYLON	1
8	99.0404	.BOLT, 1/4-20 X 1/2 BSCS	2
9	99.A06N	.LOCKNUT, NYLON 3/8-16 USS	1
10	02.CP0506	.COTTER PIN, 5/32 X 3/4	1
11	05.0002	.WASHER, FRIC. 2-1/4 X 13/32	1
12	40.0381	.LEVER, WEIGHT TRANSFER SELECT	1
13	43.C08-1R-B	.CLEVIS END, 1/2-20 RH MOD.	1
14	70.4115*	.KIT, WEIGHT TRANSFER 4500	1
15	99.E0079	.NUT, JAM 1/2-20 RH ZP	1
16	64.1619	.BRACKET, WT. TRANSFER SELECTOR	1
17	00.0314	.DECAL, WEIGHT TRANSFER	1
18	64.1612	.BUSHING, PIVOT WEIGHT TRANSFER	1
19	90.1036	.BOLT, 5/8-11 USS X 4-1/2	1
20	03.0812	.CLEVIS PIN, 1/2 X 1-1/2	1
21	99.B0099	.WASHER, FENDER 1/2" X 2" OD ZP	2
22	40.0380	.ARM, WEIGHT TRANSFER	1
23	42.0555	.ROD, WEIGHT TRANSFER ADJUSTER	1

*Weight transfer spring cannot be replaced separately. Order kit # 70.4115 and follow the kit instructions to replace with pre-assembled components.

OPTIONS

ILLUSTRATED DRAWING 3 Point Hitch Frame (Kit #70.4100)

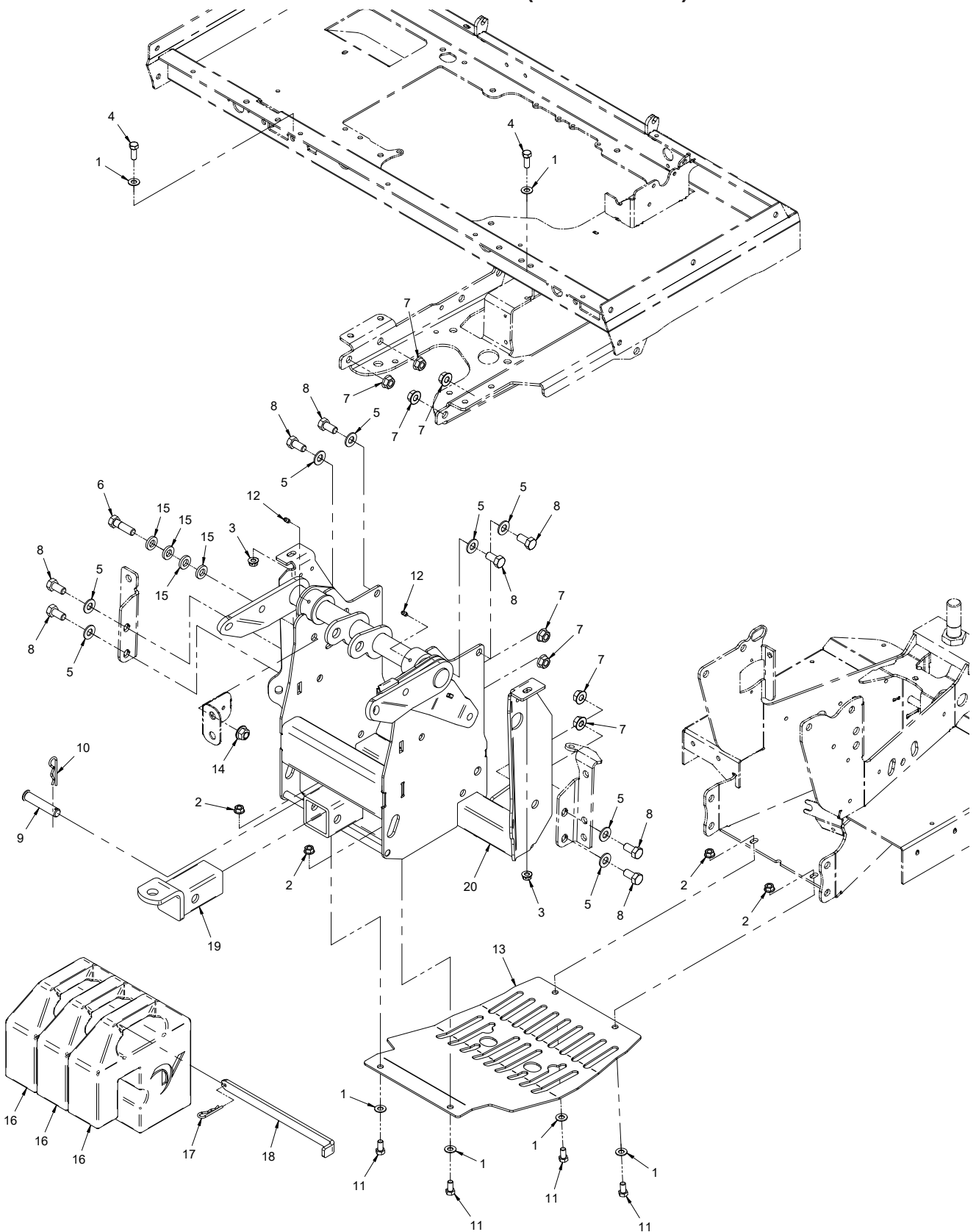

OPTIONS

3 Point Hitch Frame (Kit #70.4100)

REF.	PART NO.	DESCRIPTION	QTY.
1	95.06	.WASHER, FLAT 3/8 SAE	6
2	99.SF06	.NUT, SRF 3/8-16 USS	4
3	99.E0082	.NUT, LOCKING FLANGE 3/8-16	2
4	90.0608	.BOLT, 3/8-16 USS X 1	2
5	95.08	.WASHER, FLAT 1/2 SAE	8
6	90.0814	.BOLT, 1/2-13 USS X 1-3/4	1
7	99.SF08	.NUT, SRF 1/2-13 USS	8
8	90.0808	.BOLT, 1/2-13 USS X 1	8
9	03.1024	.CLEVIS PIN, 5/8 X 3 OAL	1
10	02.HP0420	.HAIRPIN, 1/8 X 2 1/2	1
11	90.0606	.BOLT, 3/8-16 USS X 3/4	4
12	29.GF0001	.GREASE FTG, 1/4 SAE ST	2
13	64.1868	.PLATE, REAR AXLE SKID W/3PT	1
14	99.E0103	.NUT, LOCKING FLANGE 1/2-13	1
15	99.B0092	.WASHER, 17/32ID X 1"OD X .165	4
16	47.0115-1	.WEIGHT, SUITCASE - 42 LBS	3
17	02.HP0416	.HAIRPIN, 1/8 X 2	1
18	64.1312	.PIN, WEIGHT RETAINER	1
19	62.0968	.HITCH, REAR	2
20	62.1365	.FRAME, MAIN 3-POINT HITCH	1

OPTIONS

ILLUSTRATED DRAWING 3 Point Hitch Arms (Kit #70.4100)

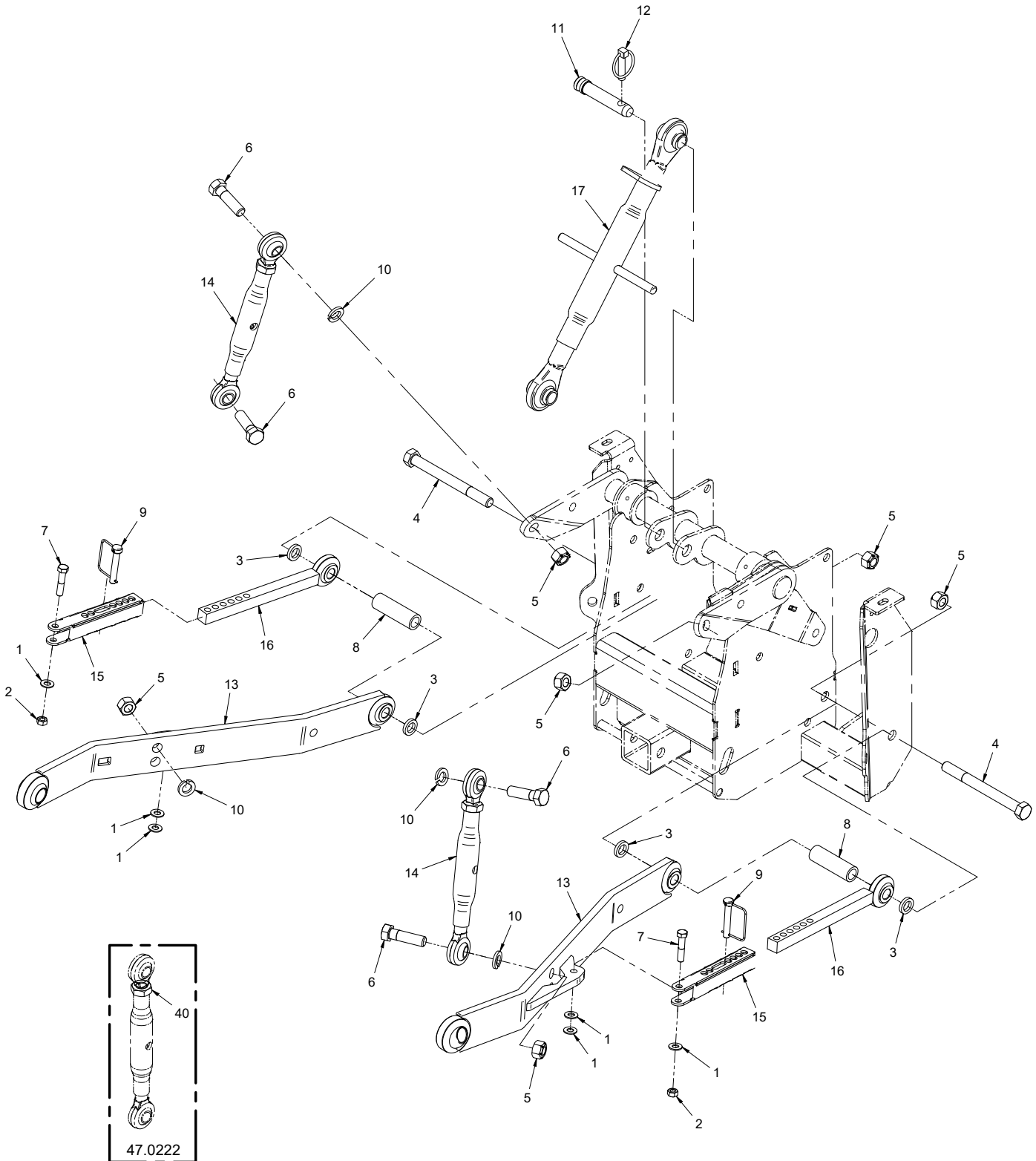

OPTIONS

3 Point Hitch Arms (Kit #70.4100)

REF.	PART NO.	DESCRIPTION	QTY.
1	95.06	.WASHER, FLAT 3/8 SAE	6
2	99.A06	.LOCKNUT, STOVER 3/8-16 USS	2
3	99.B0061	.WASHER, 3/16 X 21/32 X 1 1/32	4
4	90.1052	.BOLT, 5/8-11 USS X 6-1/2	2
5	99.A10	.LOCKNUT, STOVER 5/8-11 USS	6
6	90.1018	.BOLT, 5/8-11 USS X 2-1/4	4
7	90.0614	.BOLT, 3/8-16 USS X 1-3/4	2
8	64.1247	.BUSHING, HITCH ARM SPACER	2
9	03.0001	.PIN, SAFETY SNAP 3/8 X 1-3/4"	2
10	96.10	.WASHER, LOCK 5/8	4
11	03.0004	.PIN, TOP LINK CATEGORY 1	1
12	03.0005	.PIN, LYNCH 7/16 X 1-3/4	1
13	40.0365	.ARM, UNIVERSAL LIFT	2
14	47.0222	.TOP LINK, CAT. #0, ADJUSTABLE	2
15	42.0402	.LINK, SWAYBAR 3-POINT FEMALE	2
16	42.0403	.LINK, SWAYBAR 3-PT MALE	2
17	42.0406	.LINK, TOP CAT #1 COMPLETE	1
40	99.E0087	.NUT, JAM 3/4-10 USS	1

OPTIONS

3 Point Hitch Hydraulics (Kit #70.4100)

REF.	PART NO.	DESCRIPTION	QTY.
1	99.SF04	.NUT, SRF 1/4-20 USS	2
2	99.SF08	.NUT, SRF 1/2-13 USS	1
3	95.08	.WASHER, FLAT 1/2 SAE	2
4	90.0808	.BOLT, 1/2-13 USS X 1	1
5	99.E0103	.NUT, LOCKING FLANGE 1/2-13	3
6	02.CP0204	.COTTER PIN, 1/16 X 1/2	9
7	25.6801-06-06	.FITTING, 90 ME 3/8 X 3/8	2
8	25.2706-04-06LN	.FITTING, BULKHEAD W/ LOCKNUT	4
9	23.0106	.COUPLER, HYDRAULIC QUICK - 1/4 FEMALE	4
10	05.0116	.WASHER, .544 ID X .817 X .14 RED	2
11	05.0117	.WASHER, .544 ID X .817 X .14 YEL	2
12	23.0126	.PLUG, DUST FOR 23.0106	4
13	99.B0064	.WASHER, 1/4 X 1.75 X .531 HOLE	1
14	90.0814	.BOLT, 1/2-13 USS X 1-3/4	1
15	25.6802-06-08	.FITTING, 45 ME 3/8 X 1/2	2
16	03.0406	.CLEVIS PIN, 1/4 X 3/4	3
17	25.6400-06-06	.FITTING, M CONN 3/8 X 3/8	2
18	64.1722	.BUSHING, STEEL .563 X 1.000	1
19	64.0749	.BUSHING, STEEL 0.516 X 1.000	1
20	60.1129	.PANEL, TOOLBOX FRONT 3PT	1
21	40.0382	.LEVER, KN 3PT HYD HANDLE	3
22	99.B0092	.WASHER, 17/32ID X 1"OD X .165	4
23	99.0818	.BOLT, 1/2-13 X 2-1/4 BSCS	1
24	90.0832	.BOLT, 1/2-13 USS X 4	1
25	23.0142-6	.LINK, VALVE HANDLE "C"	3
26	99.0416	.BOLT, 1/4-20 X 2 BSCS	2
27	06.0058	.CAP, PLASTIC 1/4 X 5/8 X 1-1/2	3
28	00.0327	.DECAL, 3PT HITCH	1
29	25.6802-06-06	.FITTING, 45 ME 3/8 X 3/8	4
30	64.1701	.BRACKET, HYD. QUICK COUPLER	2
31	20.0299	.HOSE, 3/8X32.00 SAE 100R17 AR	1
32	20.0307	.HOSE, 3/8X12.00 SAE 100R17 AR	1
33	20.0308	.HOSE, 1/4X23.00 SAE 100R17 AR	1
34	20.0308	.HOSE, 1/4X23.00 SAE 100R17 AR	1
35	20.0309	.HOSE, 1/4X33.00 SAE 100R17 AR	1
36	20.0309	.HOSE, 1/4X33.00 SAE 100R17 AR	1
37	20.0309	.HOSE, 1/4X33.00 SAE 100R17 AR	1
38	20.0309	.HOSE, 1/4X33.00 SAE 100R17 AR	1
39	23.0128	.CYLINDER, 2" X 8" LIFT	1
40	23.0142-2	.VALVE, 3 SPOOL W/RH FLOAT	1
41	99.E0046	.NUT, "U" 1/4-20 EXTRUDED	4
60	23.0111-7	.KIT, SPOOL FLOAT HYD. VALVE	1
61	26.0027	.O-RING, 5/8ID X 13/16OD X 3/32	6
62	23.0111-8	.CAP, VALVE	2
65	29.GF0001	.GREASE FTG, 1/4 SAE ST	2

OPTIONS

ILLUSTRATED DRAWING 3 Point Hitch Hydraulic Diagram (Kit #70.4100)

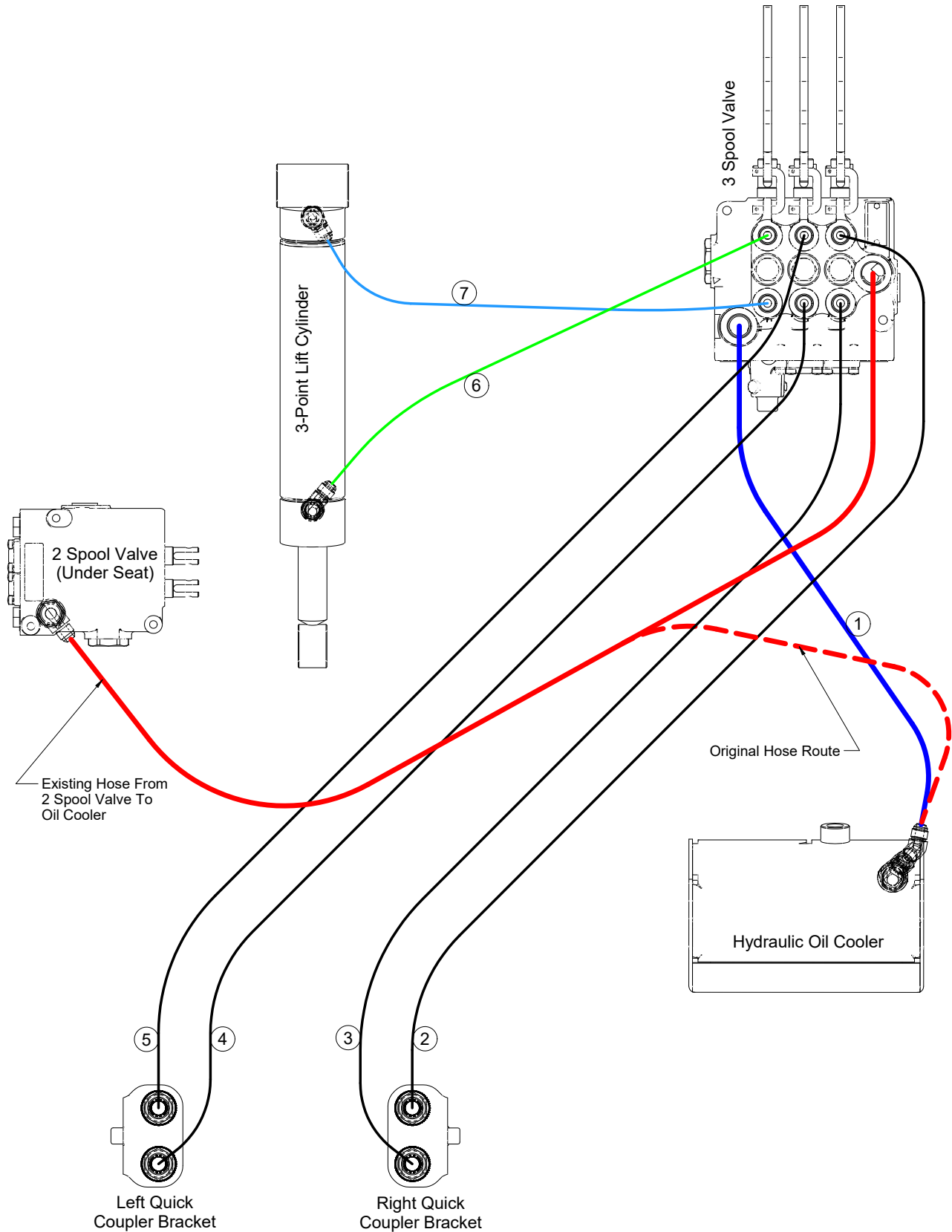

OPTIONS

3 Point Hitch Hydraulic Diagram (Kit #70.4100)

REF.	PART NO.	DESCRIPTION	QTY.
1	20.0307	.HOSE, 3/8X12.00 SAE 100R17 AR	1
2	20.0309	.HOSE, 1/4X33.00 SAE 100R17 AR	1
3	20.0309	.HOSE, 1/4X33.00 SAE 100R17 AR	1
4	20.0309	.HOSE, 1/4X33.00 SAE 100R17 AR	1
5	20.0309	.HOSE, 1/4X33.00 SAE 100R17 AR	1
6	20.0308	.HOSE, 1/4X23.00 SAE 100R17 AR	1
7	20.0308	.HOSE, 1/4X23.00 SAE 100R17 AR	1

OPTIONS

ILLUSTRATED DRAWING Rear Hydraulic Valve (Kit # 70.4126)

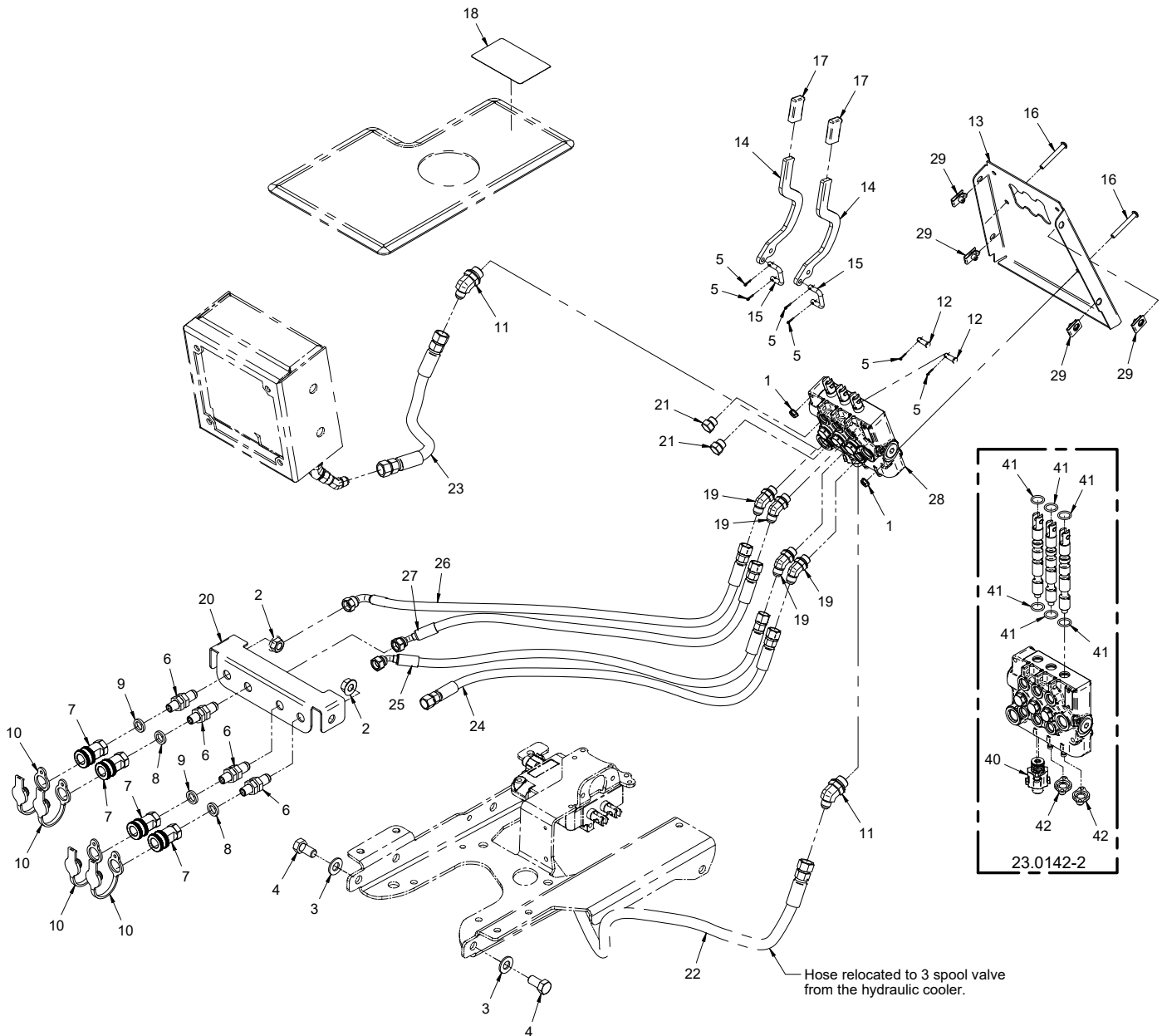

OPTIONS

Rear Hydraulic Valve (Kit # 70.4126)

REF.	PART NO.	DESCRIPTION	QTY.
1	99.SF04	.NUT, SRF 1/4-20 USS	2
2	99.SF08	.NUT, SRF 1/2-13 USS	2
3	95.08	.WASHER, FLAT 1/2 SAE	2
4	90.0808	.BOLT, 1/2-13 USS X 1	2
5	02.CP0204	.COTTER PIN, 1/16 X 1/2	6
6	25.2706-04-06LN	.FITTING, BULKHEAD W/ LOCKNUT	4
7	23.0106	.COUPLER, HYDRAULIC QUICK - 1/4 FEMALE	4
8	05.0116	.WASHER, .544 ID X .817 X .14 RED	2
9	05.0117	.WASHER, .544 ID X .817 X .14 YEL	2
10	23.0126	.PLUG, DUST FOR 23.0106	4
11	25.6802-06-08	.FITTING, 45 ME 3/8 X 1/2	2
12	03.0406	.CLEVIS PIN, 1/4 X 3/4	2
13	60.1129	.PANEL, TOOLBOX FRONT 3PT	1
14	40.0382	.LEVER, KN 3PT HYD HANDLE	2
15	23.0142-6	.LINK, VALVE HANDLE "C"	2
16	99.0416	.BOLT, 1/4-20 X 2 BSCS	2
17	06.0058	.CAP, PLASTIC 1/4 X 5/8 X 1-1/2	2
18	00.0327	.DECAL, 3PT HITCH	1
19	25.6802-06-06	.FITTING, 45 ME 3/8 X 3/8	4
20	64.1772	.BRACKET, HYD COUPLER REAR 4	1
21	25.6408-06	.FITTING, O-RING PLUG 3/8	2
22	20.0299	.HOSE, 3/8X32.00 SAE 100R17 AR	1
23	20.0307	.HOSE, 3/8X12.00 SAE 100R17 AR	1
24	20.0258	.HOSE, 1/4X27.50 SAE 100R17 AR	1
25	20.0188	.HOSE, 1/4X30.00 SAE 100R17 AR	1
26	20.0246	.HOSE, 1/4X31.00 SAE 100R17 AR	1
27	20.0188	.HOSE, 1/4X30.00 SAE 100R17 AR	1
28	23.0142-2	.VALVE, 3 SPOOL W/RH FLOAT	1
29	99.E0046	.NUT, "U" 1/4-20 EXTRUDED	4
40	23.0111-7	.KIT, SPOOL FLOAT HYD. VALVE	1
41	26.0027	.O-RING, 5/8ID X 13/16OD X 3/32	6
42	23.0111-8	.CAP, VALVE	2

OPTIONS

ILLUSTRATED DRAWING Rear Hydraulic Valve Diagram (Kit # 70.4126)

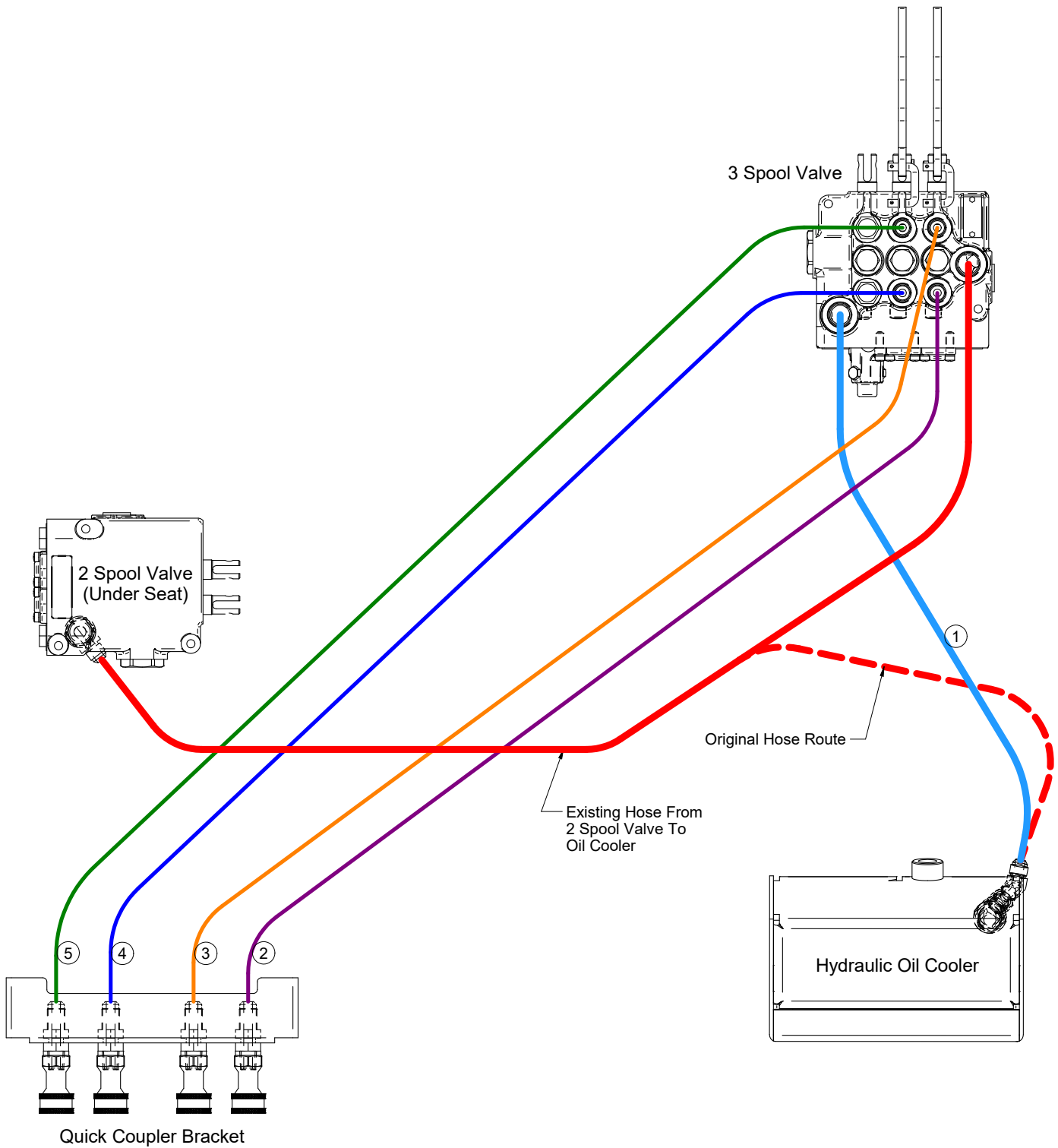

OPTIONS

Rear Hydraulic Valve Diagram (Kit # 70.4126)

REF.	PART NO.	DESCRIPTION	QTY.
1	20.0307	.HOSE, 3/8X12.00 SAE 100R17 AR	1
2	20.0258	.HOSE, 1/4X27.50 SAE 100R17 AR	1
3	20.0188	.HOSE, 1/4X30.00 SAE 100R17 AR	1
4	20.0188	.HOSE, 1/4X30.00 SAE 100R17 AR	1
5	20.0246	.HOSE, 1/4X31.00 SAE 100R17 AR	1

OPTIONS

ILLUSTRATED DRAWING Dual Wheels

Field Trax Dual Wheel Kit - # 70.4067
Turf Master Dual Wheel Kit - # 70.4068
Bar Tire Dual Wheel Kit - # 70.4069

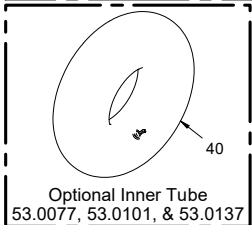
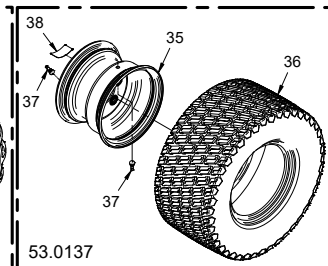
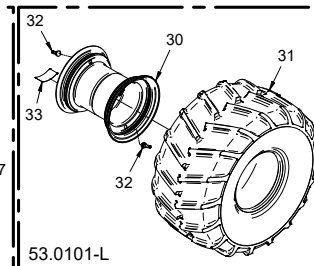
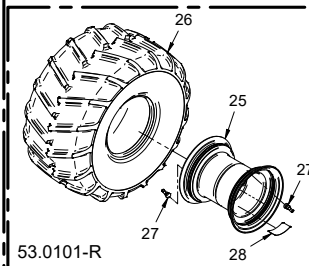
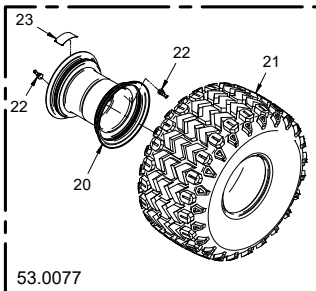
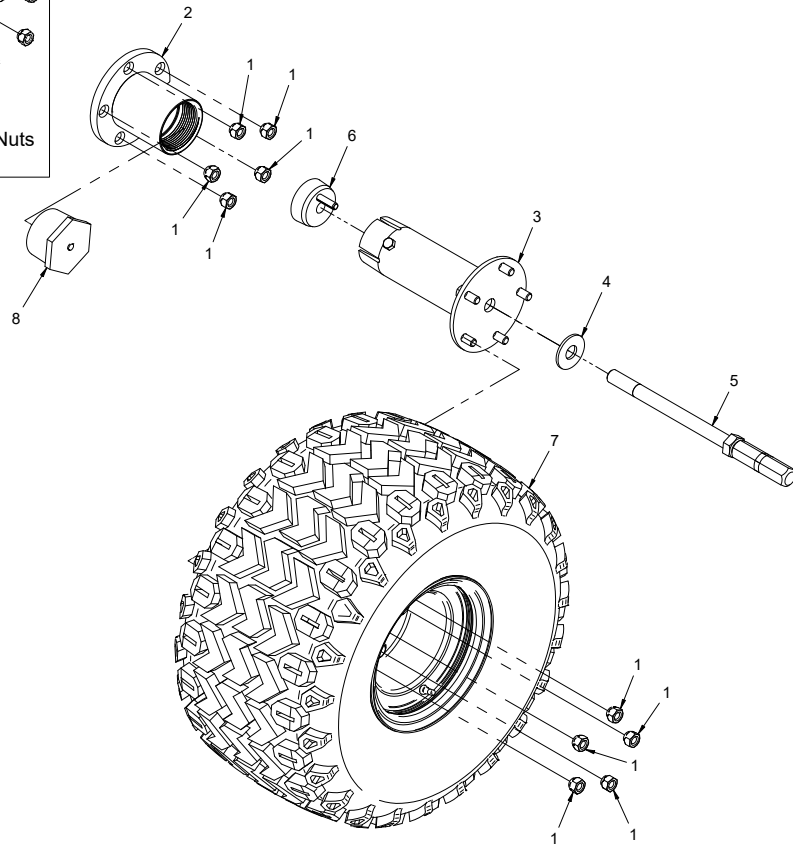
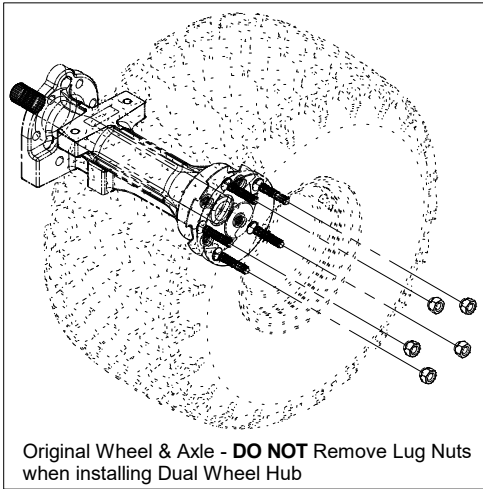

OPTIONS

Dual Wheels

REF.	PART NO.	DESCRIPTION	QTY.
1	99.E0044	.NUT, LUG 7/16-20 SAE	40
2	50.0190	.HUB, DUAL WHEEL	4
3	50.0061	.EXTENSION, DUAL WHEEL KT	4
4	94.12	.WASHER, FLAT 3/4 USS	4
5	64.0672	.BOLT, 3/4" DRAWBOLT DUALS.	4
6	50.0063	.CONE, 3/4 DRAWCONE DUALS.	4
7	53.0077	.WHEEL, ASM 22 X 12 X 8 X 5B	4
7	53.0101-L	.WHEEL, ASM 21 X 11 X 8 X 5B BAR.	2
7	53.0101-R	.WHEEL, ASM 21 X 11 X 8 X 5B BAR.	2
7	53.0137	.WHEEL, ASM 22 X 11 X 10 X 5B TURF	4
8	05.0093	.PLUG, 2-1/2 NPT M, WHT PLASTIC	4
20	53.0090	.RIM, 8 X 8.5, 5 ON 4.5 BC	1
21	53.0089	.TIRE, FIELD 22 X 12 X 8-NO RIM	1
22	53.0139	.VALVE STEM	2
23	00.0348	.DECAL, WARNING HUB SIDE (Serial # 01001-14497)	1
23	00.0645	.DECAL, HUB SIDE (Serial # 14498-)	1
25	53.0090	.RIM, 8 X 8.5, 5 ON 4.5 BC	1
26	53.0114	.TIRE, BAR 21X11X8 NO RIM	1
27	53.0139	.VALVE STEM	2
28	00.0348	.DECAL, WARNING HUB SIDE (Serial # 01001-14497)	1
28	00.0645	.DECAL, HUB SIDE (Serial # 14498-)	1
30	53.0090	.RIM, 8 X 8.5, 5 ON 4.5 BC	1
31	53.0114	.TIRE, BAR 21X11X8 NO RIM	1
32	53.0139	.VALVE STEM	2
33	00.0348	.DECAL, WARNING HUB SIDE (Serial # 01001-14497)	1
33	00.0645	.DECAL, HUB SIDE (Serial # 14498-)	1
35	53.0138	.RIM, 10 X 7 - 5 ON 4.5 BC	1
36	53.0112	.TIRE, TURFMASTR 22X11X10 NO RIM	1
37	53.0139	.VALVE STEM	2
38	00.0348	.DECAL, WARNING HUB SIDE (Serial # 01001-14497)	1
38	00.0645	.DECAL, HUB SIDE (Serial # 14498-)	1
40	53.0142	.TUBE, INNER 22 X 12 X 8	1

OPTIONS

ILLUSTRATED DRAWING 70.4111 Suspension Seat Kit

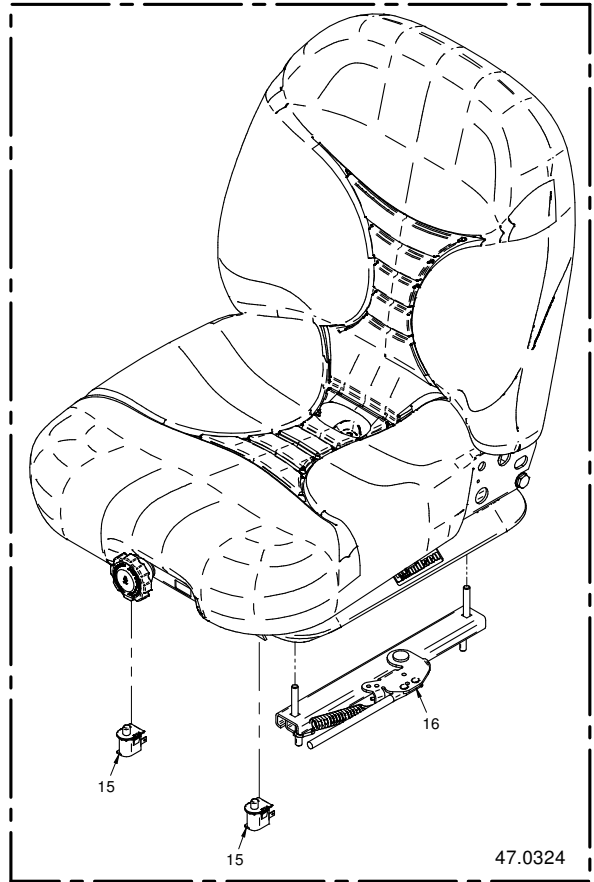
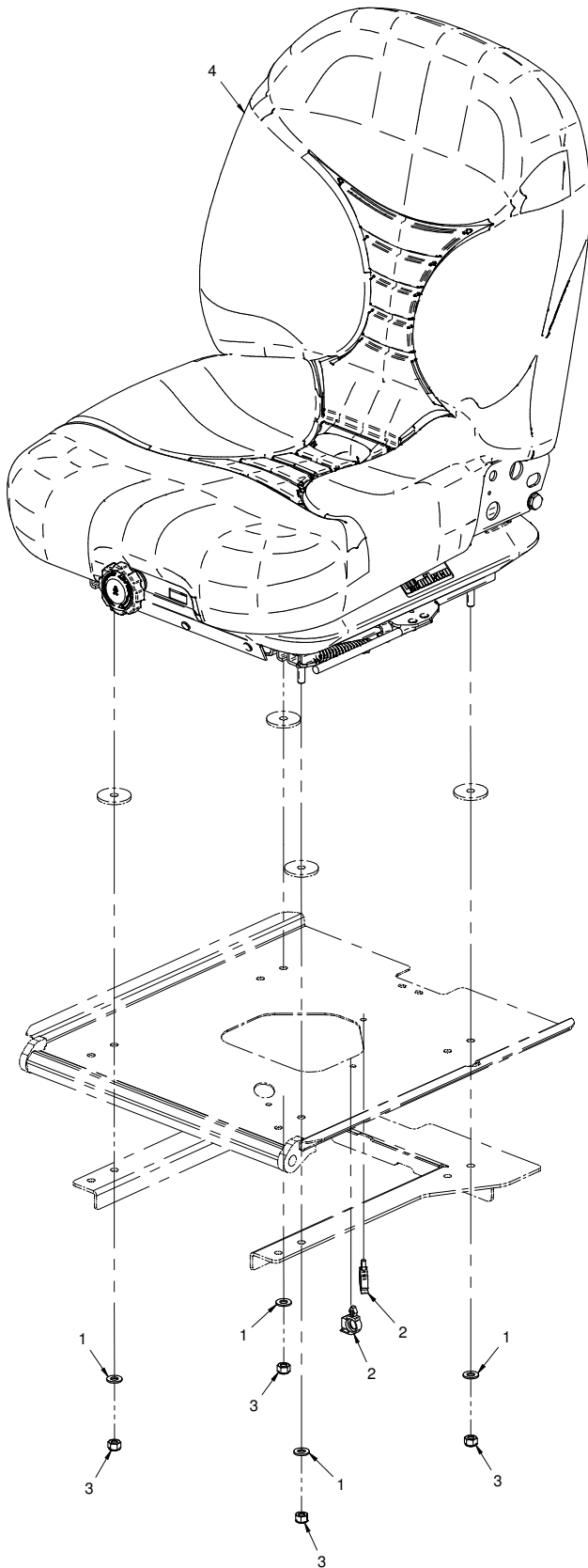

OPTIONS

70.4111 Suspension Seat Kit

REF.	PART NO.	DESCRIPTION	QTY.
1	95.05	.WASHER, FLAT 5/16 SAE	4
2	30.0135	.CLAMP, LOOM 3/8 ROSEBUD MOUNT	2
3	99.A05N	.LOCKNUT, NYLON 5/16-18 USS	4
4	47.0324	.SEAT, SUSPENSION	1
15	31.0062	.SWITCH, SEAT WITH RUBBER BOOT	2
16	47.0324-1	.SEAT SLIDE, LEFT W/ ADJUSTMENT HANDLE	1

OPTIONS

ILLUSTRATED DRAWING 70.4154 Suspension Seat Kit

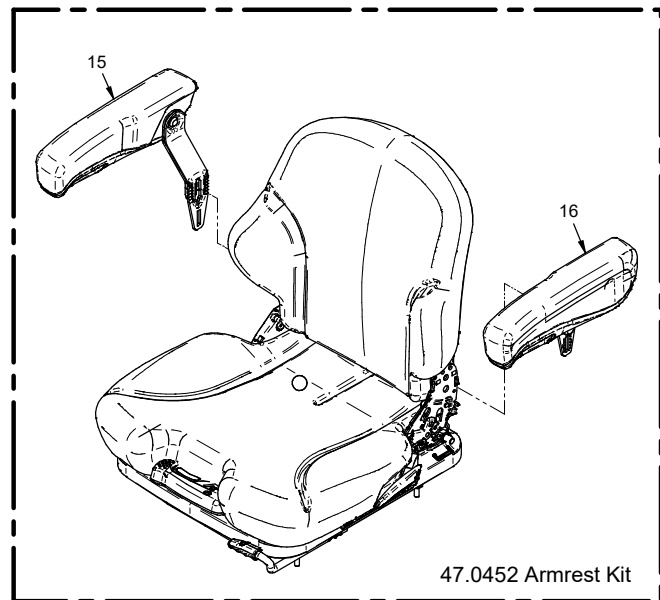
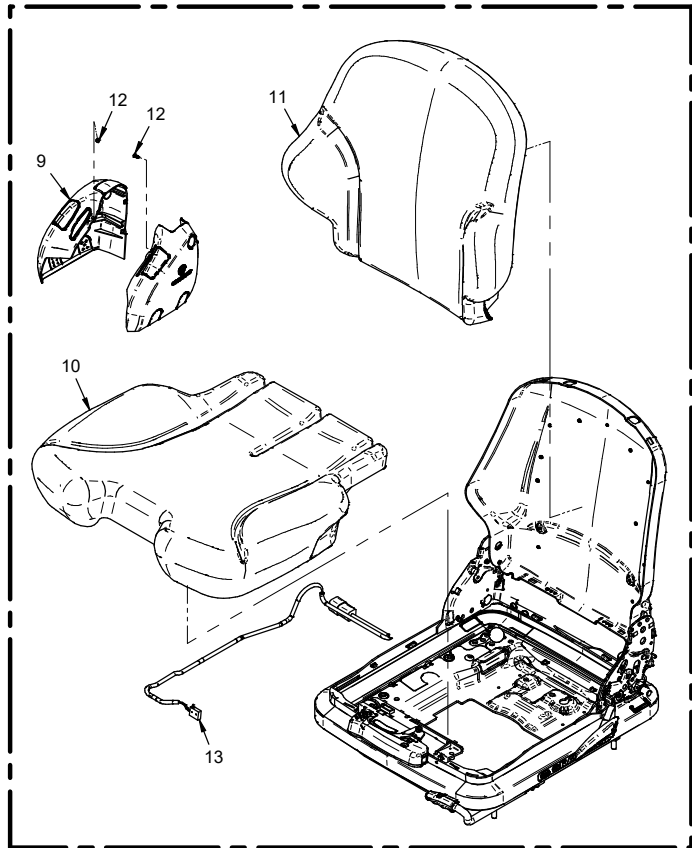
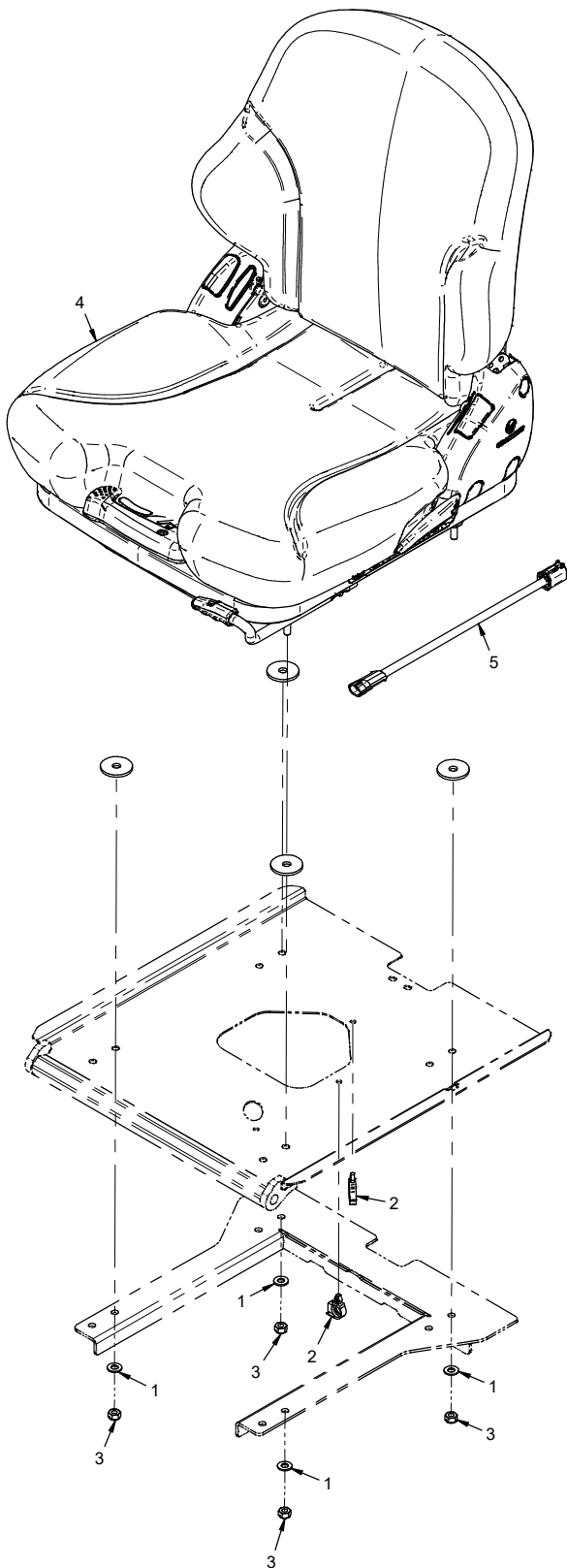

47.0452 Armrest Kit

OPTIONS

70.4154 Suspension Seat Kit

REF.	PART NO.	DESCRIPTION	QTY.
1	95.05	.WASHER, FLAT 5/16 SAE	4
2	30.0135	.CLAMP, LOOM 3/8 ROSEBUD MOUNT	2
3	99.M0068	.NUT, M8 X 1.25 NYLON LOCK	4
4	70.4154	.KIT, SUSPENSION SEAT	1
5	32.0212	.HARNESS, WIRE GRAMMER SEAT	1
9	47.0482	.COVER, LEFT & RIGHT SIDE (SET)	1
10	47.0467	.CUSHION, SEAT	1
11	47.0468	.CUSHION, BACKREST	1
12	04.0049	.RIVET, SIDE COVERS FOR GRAMMER SEAT	2
13	31.0075	.SWITCH, SEAT	1
15	47.0452-R	.ARMREST, RIGHT - SUSPENSION SEAT	1
16	47.0452-L	.ARMREST, LEFT - SUSPENSION SEAT	1

OPTIONS

ILLUSTRATED DRAWING 70.0098 Canopy Kit

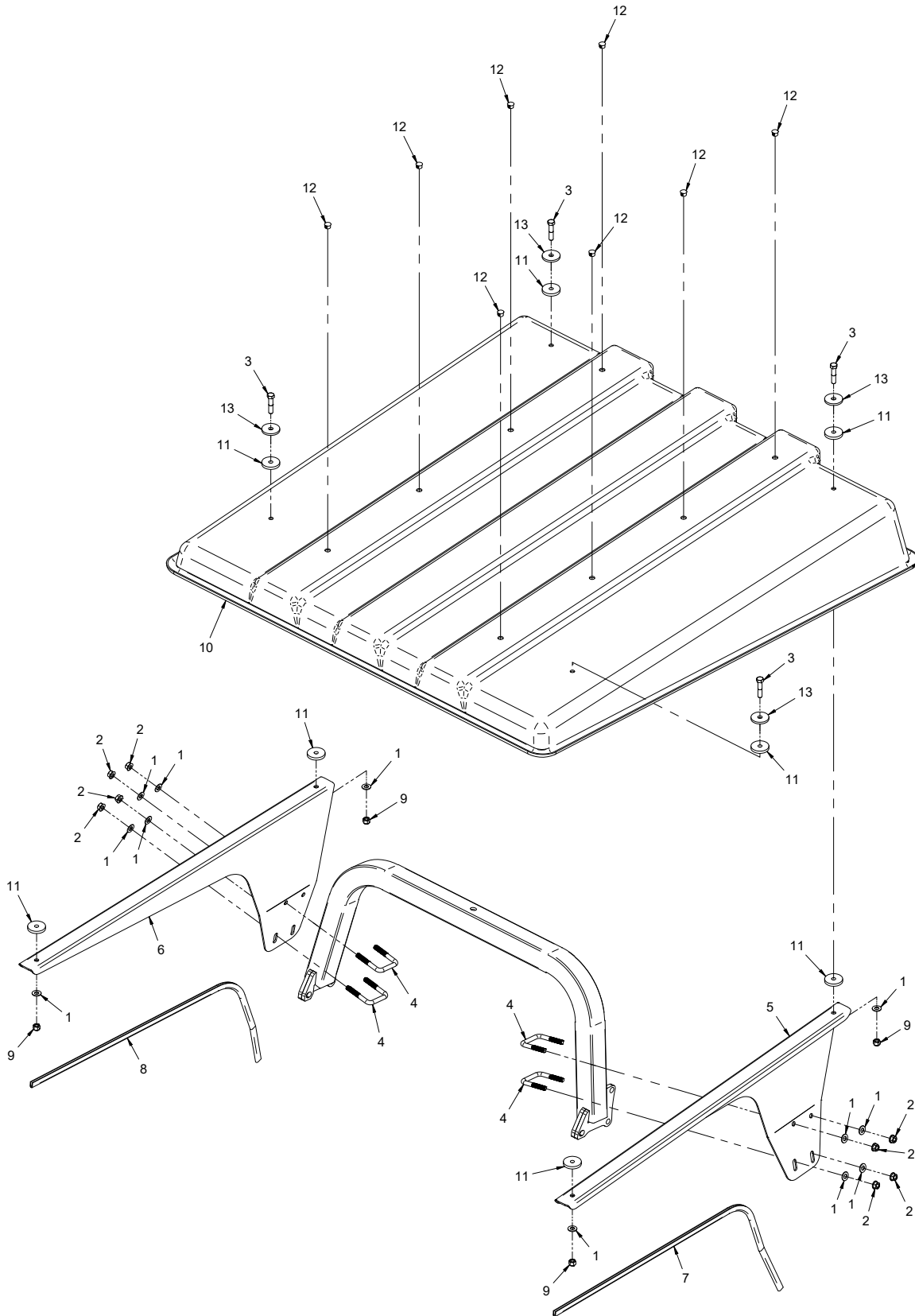

OPTIONS

70.0098 Canopy Kit

REF.	PART NO.	DESCRIPTION	QTY.
1	95.06	.WASHER, FLAT 3/8 SAE	12
2	99.SF06	.NUT, SRF 3/8-16 USS.	8
3	90.0614	.BOLT, 3/8-16 USS X 1-3/4.	4
4	11.0053	.U-BOLT, 3/8-16 2-1/16" ID SQ BEND.	4
5	62.0915	.FRAME, CANOPY LEFT SIDE	1
6	62.0914	.FRAME, CANOPY RIGHT SIDE	1
7	06.0050-41IN	.TRIM, TRIM LOC 1/2 X 3/16 X 41"	1
8	06.0050-41IN	.TRIM, TRIM LOC 1/2 X 3/16 X 41"	1
9	99.A06N	.LOCKNUT, NYLON 3/8-16 USS.	4
10	47.0186	.CANOPY, SHELL ONLY, WHITE	1
11	05.0085	.WASHER, NEOPRENE	8
12	05.0086	.PLUG, 1/2" HOLE, NYLON-WHITE	8
13	99.B0076	.WASHER, .185 X 13/32 ID X 1-5/8.	4

OPTIONS

ILLUSTRATED DRAWING 70.4113 Work Light Kit

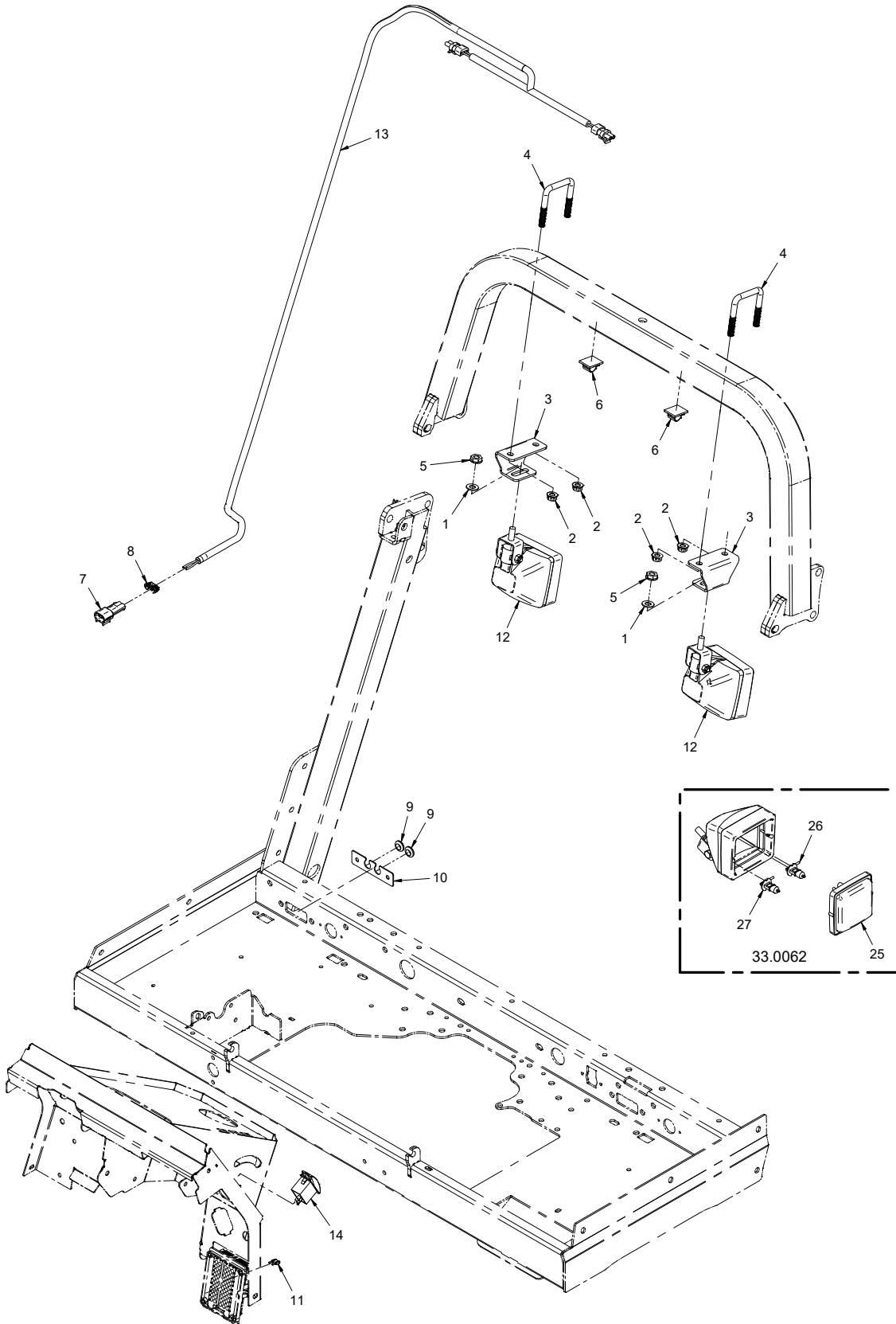

OPTIONS

70.4113 Work Light Kit

REF.	PART NO.	DESCRIPTION	QTY.
1	95.06	.WASHER, FLAT 3/8 SAE	2
2	99.E0082	.NUT, LOCKING FLANGE 3/8-16	4
3	64.1706	.BRACKET, WORKLIGHT MOUNT KN	2
4	11.0053	.U-BOLT, 3/8-16 2-1/16" ID SQ BEND	2
5	99.M0021	.NUT, SMF M10 X 1.5	2
6	30.0217	.CLAMP, WIRE MT ADH. 1/2 GRAY	2
7	30.0322	.CONNECTOR, MP280 MALE BODY	1
8	30.0326	.CLIP, MP280 CONNECTOR	1
9	05.0136	.GROMMET, 7/16ID, 3/4OD, 1/4THK	2
10	60.1175	.COVER, OPT. LIGHT KIT ACCESS	1
11	30.0334	.FUSE, 15 AMP MINI BLUE	1
12	33.0062	.LIGHT, WORK 3 X 3	2
13	32.0116	.HARNES, WIRE WORK LIGHT	1
14	31.0053	.SWITCH, ROCKER ON/OFF	1
25	33.0054	.OPTICAL UNIT, LENS/REFLECTOR	1
26	33.0055	.BULB, LIGHT (ONLY) FOR 55 WATT	1
27	33.0056	.BULB, LIGHT (ONLY) FOR 35 WATT (Optional)	1

OPTIONS

ILLUSTRATED DRAWING 70.4114 Strobe Light Kit

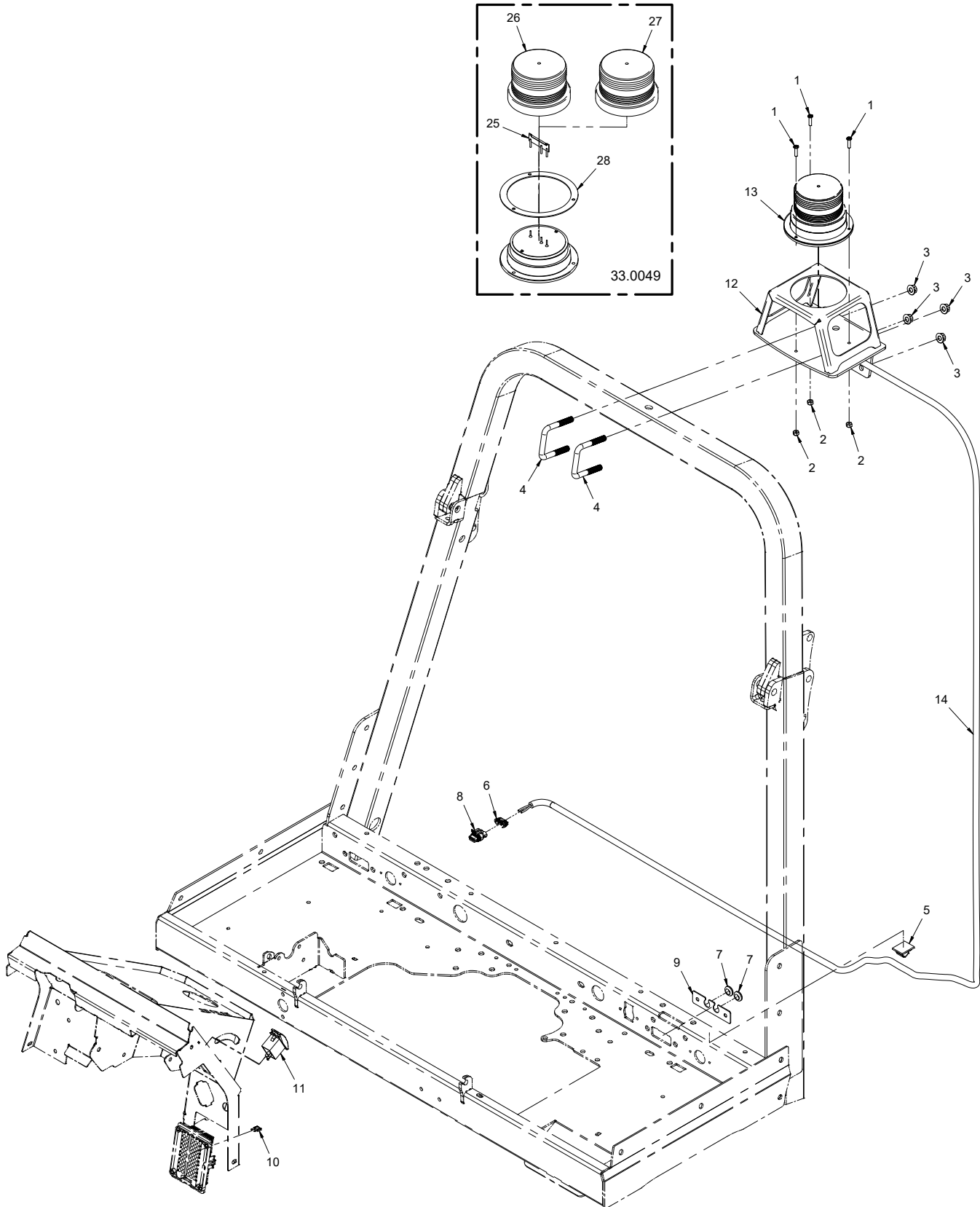

OPTIONS

70.4114 Strobe Light Kit

REF.	PART NO.	DESCRIPTION	QTY.
1	99.K0047	MACHINE SCREW, #10-32 X 3/4	3
2	99.A1032N	LOCKNUT, NYLON 10-32 STAINLESS	3
3	99.E0082	NUT, LOCKING FLANGE 3/8-16	4
4	11.0053	U-BOLT, 3/8-16 2-1/16" ID SQ BEND	2
5	30.0217	CLAMP, WIRE MT ADH. 1/2 GRAY	1
6	30.0326	CLIP, MP280 CONNECTOR	1
7	05.0136	GROMMET, 7/16ID, 3/4OD, 1/4THK	2
8	30.0323	CONNECTOR, MP280 FEMALE BODY	1
9	60.1175	COVER, OPT. LIGHT KIT ACCESS	1
10	30.0334	FUSE, 15 AMP MINI BLUE	1
11	31.0053	SWITCH, ROCKER ON/OFF	1
12	62.1383	FRAME, LIGHT BAR	1
13	33.0049	LIGHT, STROBE AMBER	1
14	32.0117	HARNESS, WIRE STROBE LIGHT	1
25	33.0052	BULB, STROBE LIGHT FOR 33.0049	1
26	33.0050	LENS, STROBE - AMBER 3-1/2"	1
27	33.0051	LENS, STROBE - BLUE 3-1/2" (Optional)	1
28	33.0049-1	RING, CLAMP	1

OPTIONS

ILLUSTRATED DRAWING 70.4155 Strobe Light Kit

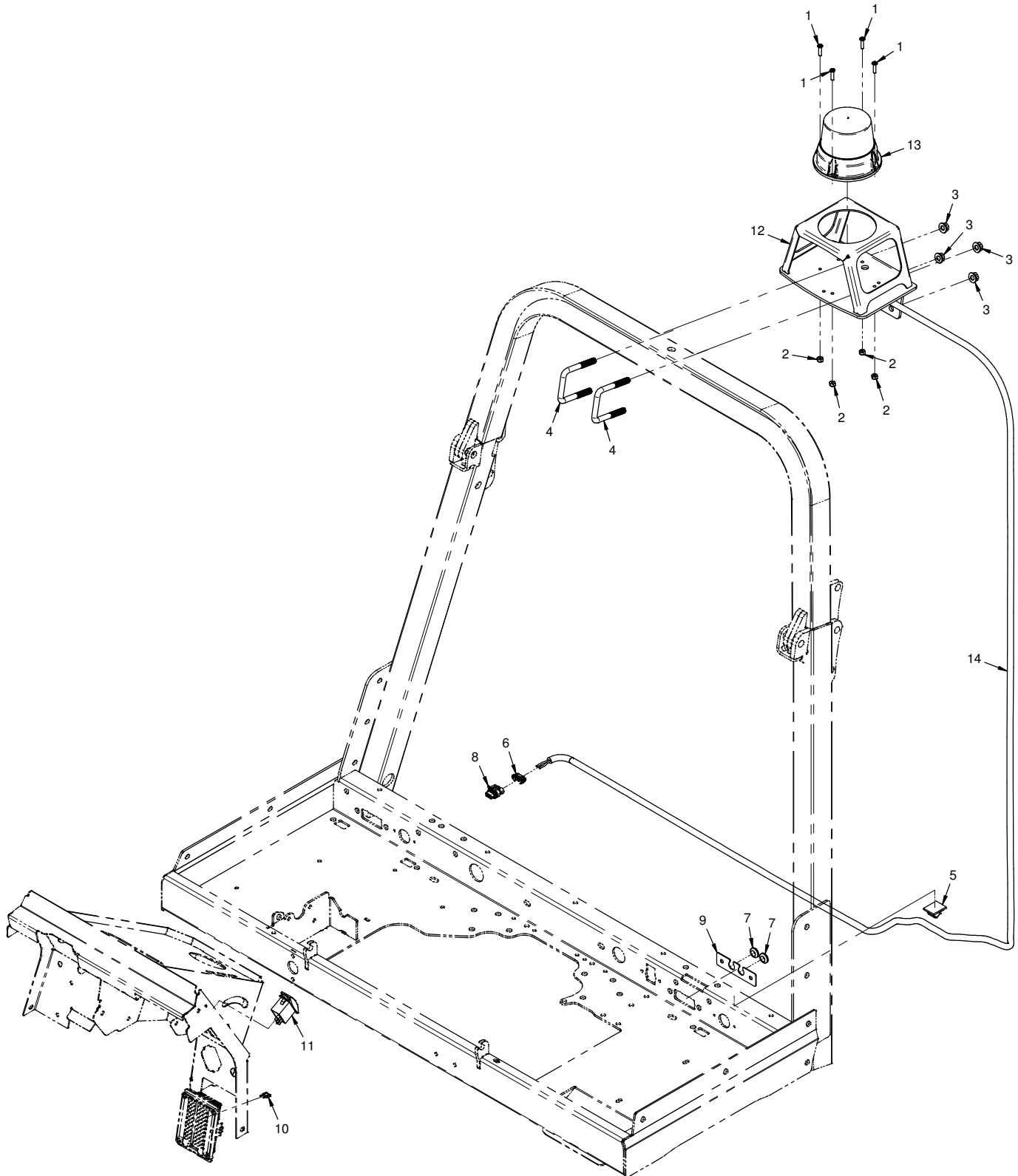

OPTIONS

70.4155 Strobe Light Kit

REF.	PART NO.	DESCRIPTION	QTY.
1	99.K0047	MACHINE SCREW, #10-32 X 3/4	4
2	99.A1032N	LOCKNUT, NYLON 10-32 STAINLESS	4
3	99.E0082	NUT, LOCKING FLANGE 3/8-16	4
4	11.0053	U-BOLT, 3/8-16 2-1/16" ID SQ BEND	2
5	30.0217	CLAMP, WIRE MT ADH. 1/2 GRAY	1
6	30.0326	CLIP, MP280 CONNECTOR	1
7	05.0136	GROMMET, 7/16ID, 3/4OD, 1/4THK	2
8	30.0323	CONNECTOR, MP280 FEMALE BODY	1
9	60.1175	COVER, OPT. LIGHT KIT ACCESS	1
10	30.0334	FUSE, 15 AMP MINI BLUE	1
11	31.0053	SWITCH, ROCKER ON/OFF	1
12	62.1383	FRAME, STROBE LIGHT	1
13	33.0073	LIGHT, STROBE AMBER	1
14	32.0117	HARNESS, WIRE STROBE LIGHT	1

OPTIONS

ILLUSTRATED DRAWING 70.4119 Directional / Hazard Light Kit

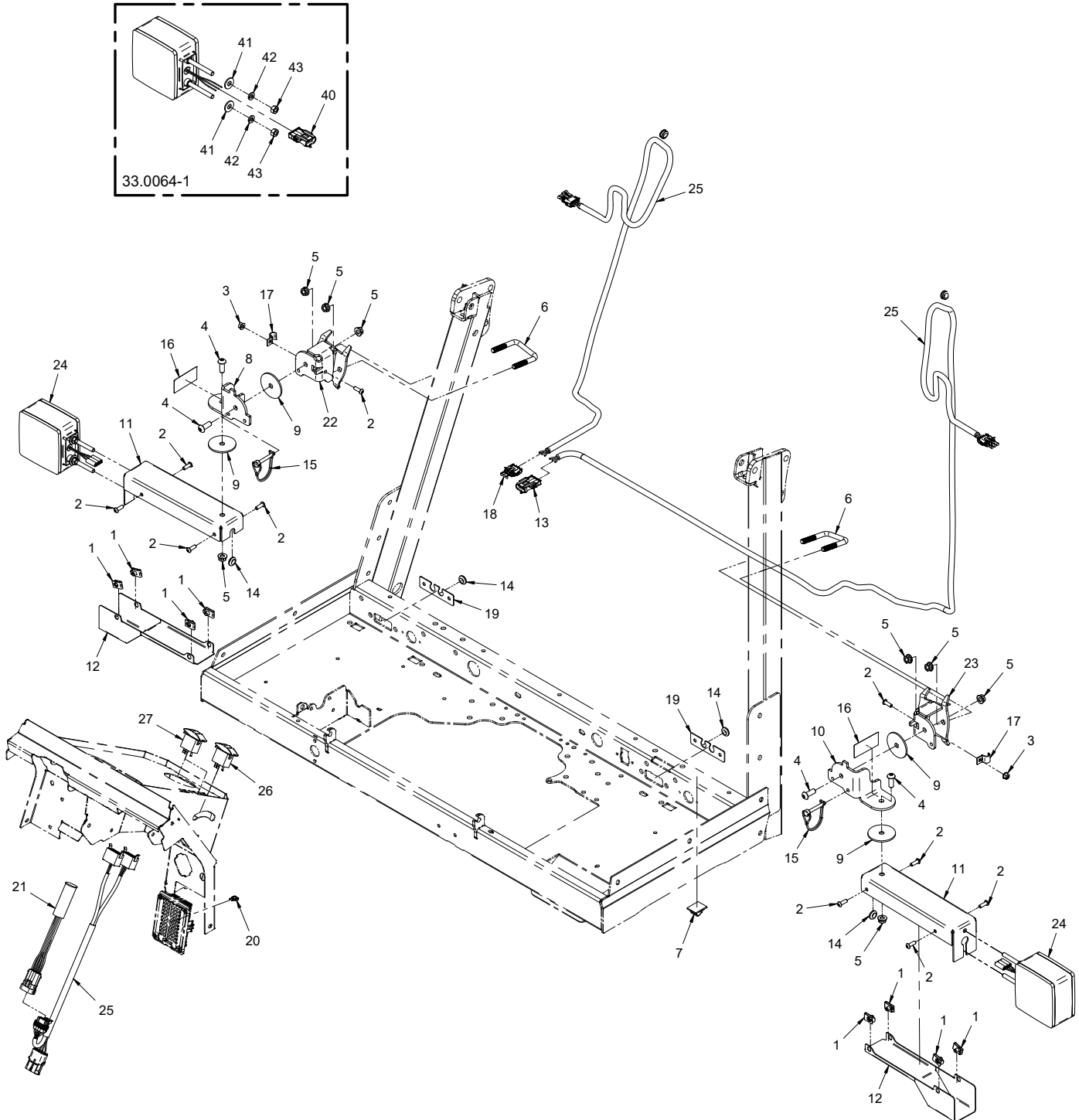

OPTIONS

70.4119 Directional / Hazard Light Kit

REF.	PART NO.	DESCRIPTION	QTY.
1	99.E0046	.NUT, "U" 1/4-20 EXTRUDED	8
2	99.0406	.BOLT, 1/4-20 X 3/4 BSCS	10
3	99.E0101	.NUT, LOCKING FLANGE 1/4-20	2
4	99.0608	.BOLT, 3/8-16 X 1 BSCS	4
5	99.E0082	.NUT, LOCKING FLANGE 3/8-16	8
6	11.0053	.U-BOLT, 3/8-16 2-1/16" ID SQ BEND	2
7	30.0217	.CLAMP, WIRE MT ADH. 1/2 GRAY	1
8	64.1713	.BRACKET, DIRECTIONAL PIVOT RH	1
9	05.0002	.WASHER, FRIC. 2-1/4 X 13/32	4
10	64.1714	.BRACKET, DIRECTIONAL PIVOT LH	1
11	40.0388	.ARM, DIRECTIONAL LIGHT	2
12	60.1176	.COVER, DIRECTONAL SIGNAL ARM	2
13	30.0423	.CONNECTOR, WPAK 3 POS MALE	1
14	05.0136	.GROMMET, 7/16ID, 3/4OD, 1/4THK	4
15	03.0009	.PIN, SAFETY SNAP 1/4 X 1-3/8	2
16	00.0218	.DECAL, WARNING PINCH POINT	2
17	11.0072	.CLAMP, 1/2 LOOP VINYL	2
18	30.0422	.CONNECTOR, WPAK 3 POS FEMALE	1
19	60.1175	.COVER, OPT. LIGHT KIT ACCESS	2
20	30.0333	.FUSE, 10 AMP MINI RED	1
21	35.0127	.MODULE, DIRECTIONAL LIGHT	1
22	64.1715	.BRACKET, ROLLBAR MOUNT RH	1
23	64.1716	.BRACKET, ROLLBAR MOUNT LH	1
24	33.0064-1	.LIGHT, LED DOUBLE FACE - AMBER	2
25	32.0118	.HARNESS, WIRE DIRECTIONAL (Includes Splitter & Front Switch Connectors)	1
26	31.0055	.SWITCH, ROCKER ON/OFF/ON	1
27	31.0053	.SWITCH, ROCKER ON/OFF	1
40	30.0423	.CONNECTOR, WPAK 3 POS MALE	1
41	94.05	.WASHER, FLAT 5/16 USS	2
42	96.05	.WASHER, LOCK 5/16	2
43	92.05	.NUT, 5/16-18 USS	2

OPTIONS

ILLUSTRATED DRAWING 70.4156 Directional / Hazard ECE Light Kit

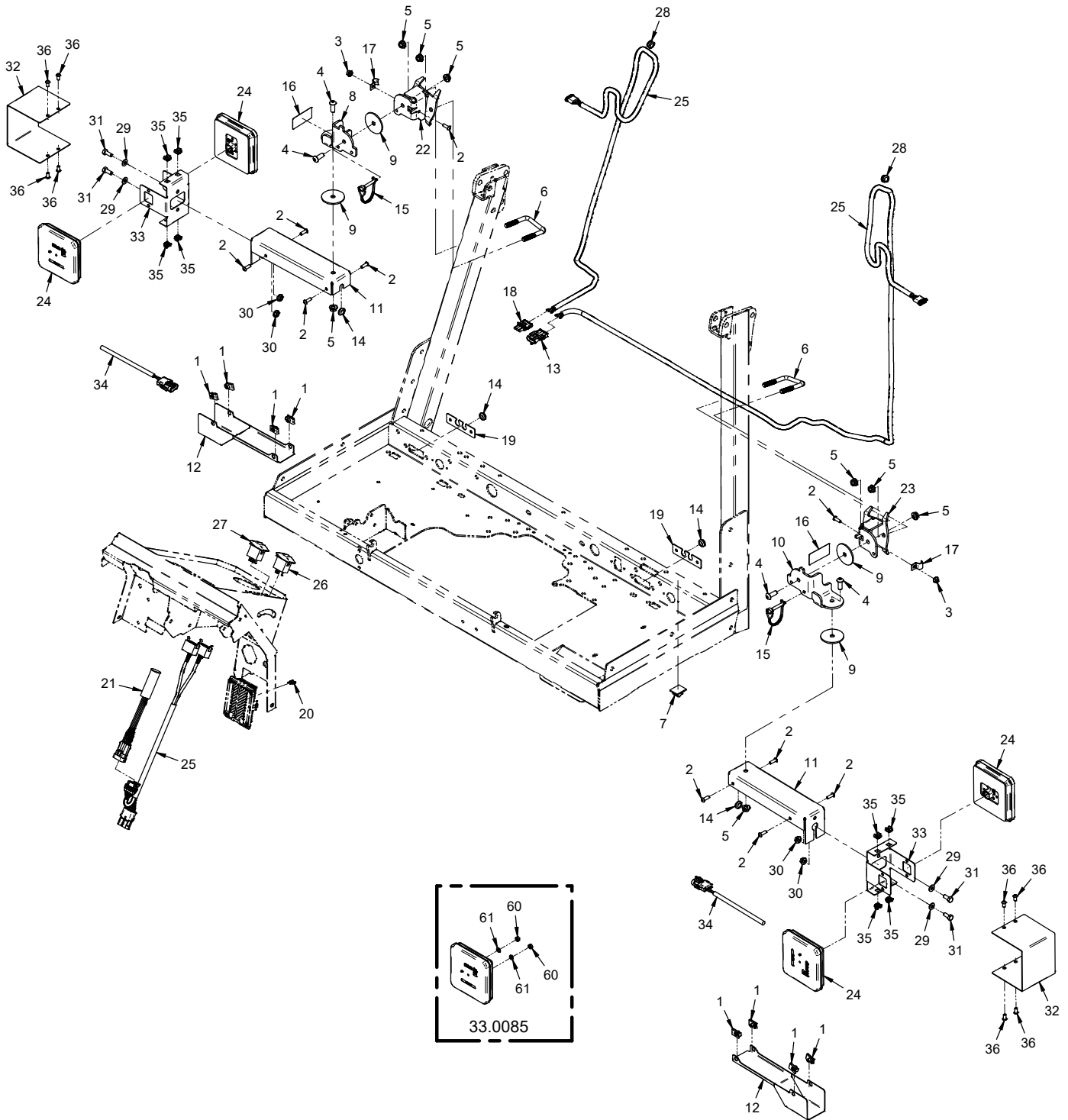

OPTIONS

70.4156 Directional / Hazard ECE Light Kit

REF.	PART NO.	DESCRIPTION	QTY.
1	99.E0046	.NUT, "U" 1/4-20 EXTRUDED	8
2	99.0406	.BOLT, 1/4-20 X 3/4 BSCS	10
3	99.E0101	.NUT, LOCKING FLANGE 1/4-20	2
4	99.SF0608-1	.BOLT, SMF 3/8-16 X 1	4
5	99.E0082	.NUT, LOCKING FLANGE 3/8-16	8
6	11.0053	.U-BOLT, 3/8-16 2-1/16" ID SQ BEND	2
7	30.0217	.CLAMP, WIRE MT ADH. 1/2 GRAY	1
8	64.1713	.BRACKET, DIRECTIONAL PIVOT RH	1
9	05.0002	.WASHER, FRIC. 2-1/4 X 13/32	4
10	64.1714	.BRACKET, DIRECTIONAL PIVOT	1
11	40.0388	.ARM, DIRECTIONAL LIGHT	2
12	60.1176	.COVER, DIRECTIONAL SIGNAL ARM	2
13	30.0423	.CONNECTOR, WPAK 3 POS MALE	1
14	05.0136	.GROMMET, 7/16ID, 3/4OD, 1/4THK	4
15	03.0009	.PIN, SAFETY SNAP 1/4 X 1-3/8	2
16	00.0218	.DECAL, WARNING PINCH POINT (Serial # 01001-14497)	2
16	00.0364	.DECAL, PINCH POINT HAZARD (Serial # 14498-)	2
17	11.0072	.CLAMP, 1/2 LOOP VINYL	2
18	30.0422	.CONNECTOR, WPAK 3 POS FEMALE	1
19	60.1175	.COVER, OPT. LIGHT KIT ACCESS	2
20	30.0333	.FUSE, 10 AMP MINI RED	1
21	35.0161	.MODULE, DIRECTIONAL/HAZARD LIGHT	1
22	64.1715	.BRACKET, ROLLBAR MOUNT RH	1
23	64.1716	.BRACKET, ROLLBAR MOUNT LH	1
24	33.0085	.LIGHT, ASM LED SINGLE FACE - AMBER	4
25	32.0118	.HARNESS, WIRE DIRECTIONAL (Includes Splitter & Front Switch Connectors)	1
26	31.0055	.SWITCH, ROCKER ON/OFF/ON	1
27	31.0053	.SWITCH, ROCKER ON/OFF	1
28	05.0138	.GROMMET, 7/16ID, 11/16OD, 3/8THK	2
29	95.05	.WASHER, FLAT 5/16 SAE	4
30	99.SF05	.NUT, SRF 5/16-18 USS	4
31	90.0506	.BOLT, 5/16-18 USS X 3/4"	4
32	64.2015	.COVER, SIGNAL LIGHT	2
33	64.2016	.BRACKET, SIGNAL LIGHT	2
34	32.0217	.HARNESS, 4500 DIRECTIONAL/HAZARD ECE	2
35	99.E0145	.NUT, CAGE 1/4-20 (.025-.063")	8
36	99.0404	.BOLT, 1/4-20 X 1/2 BSCS	8
60	99.M0031	.NUT, M6 X 1.00	2
61	96.04	.WASHER, LOCK 1/4	2

OPTIONS

ILLUSTRATED DRAWING 70.4098 Wheel Extension Kit

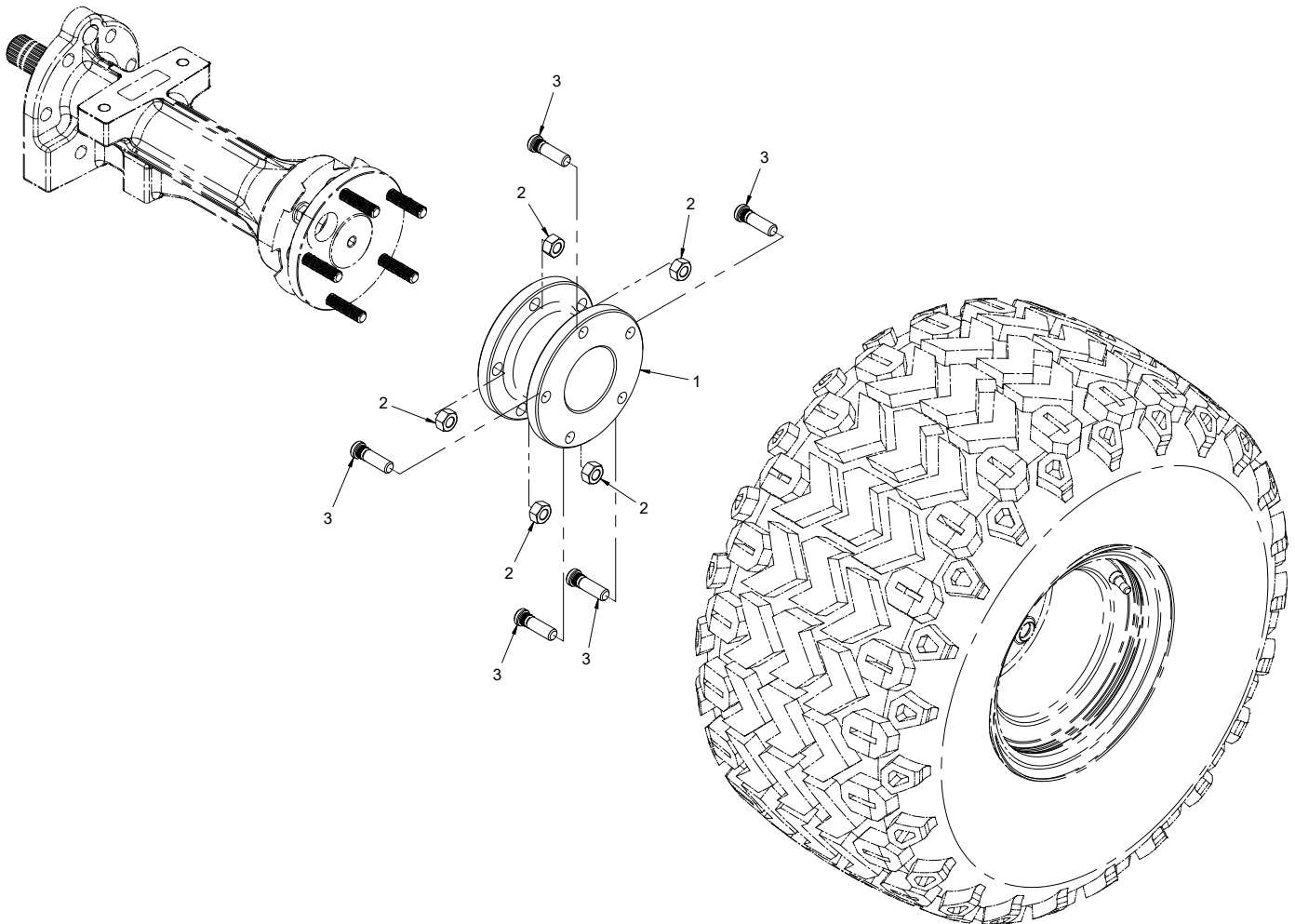

OPTIONS

70.4098 Wheel Extension Kit

REF.	PART NO.	DESCRIPTION	QTY.
1	53.0144	.HUB, 3" WHEEL EXTENSION	4
2	93.07	.NUT, 7/16-20 SAE	20
3	99.K0120	.BOLT, 7/16-20 X 1-1/2 WHL STUD	20

OPTIONS

ILLUSTRATED DRAWING 70.4107 Foot Control Kit

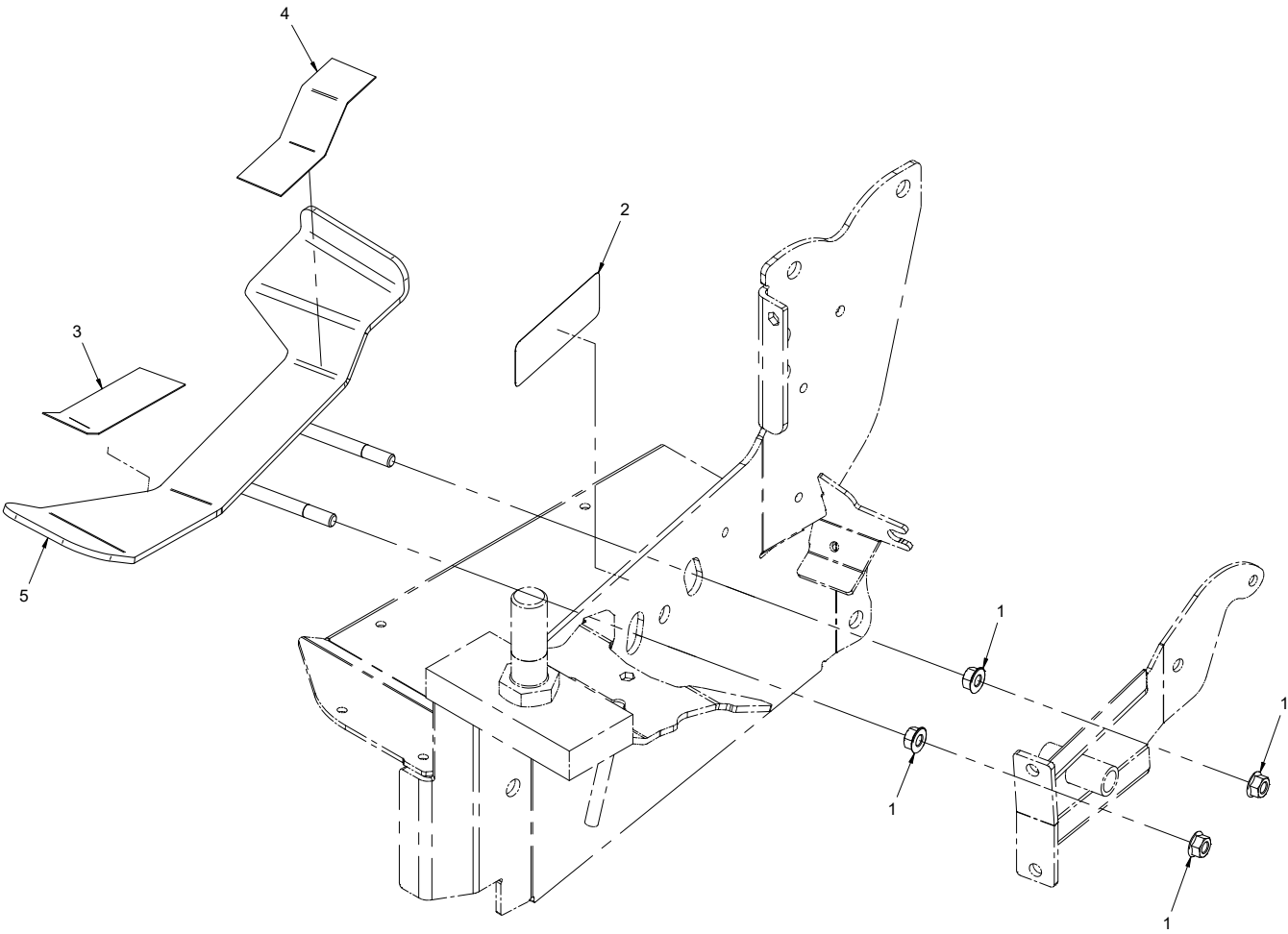

OPTIONS

70.4107 Foot Control Kit

REF.	PART NO.	DESCRIPTION	QTY.
1	99.SF06	NUT, SRF 3/8-16 USS.	4
2	00.0338	DECAL, FOOT CONTROL.	1
3	56.0055-1.5IN	FLEX TREAD, 5" BLACK COARSE X 1-1/2"	1
4	56.0055-1.5IN	FLEX TREAD, 5" BLACK COARSE X 1-1/2"	1
5	62.1377	PEDAL, FOOT KN.	1

OPTIONS

ILLUSTRATED DRAWING 70.4108 Raised Platform Kit

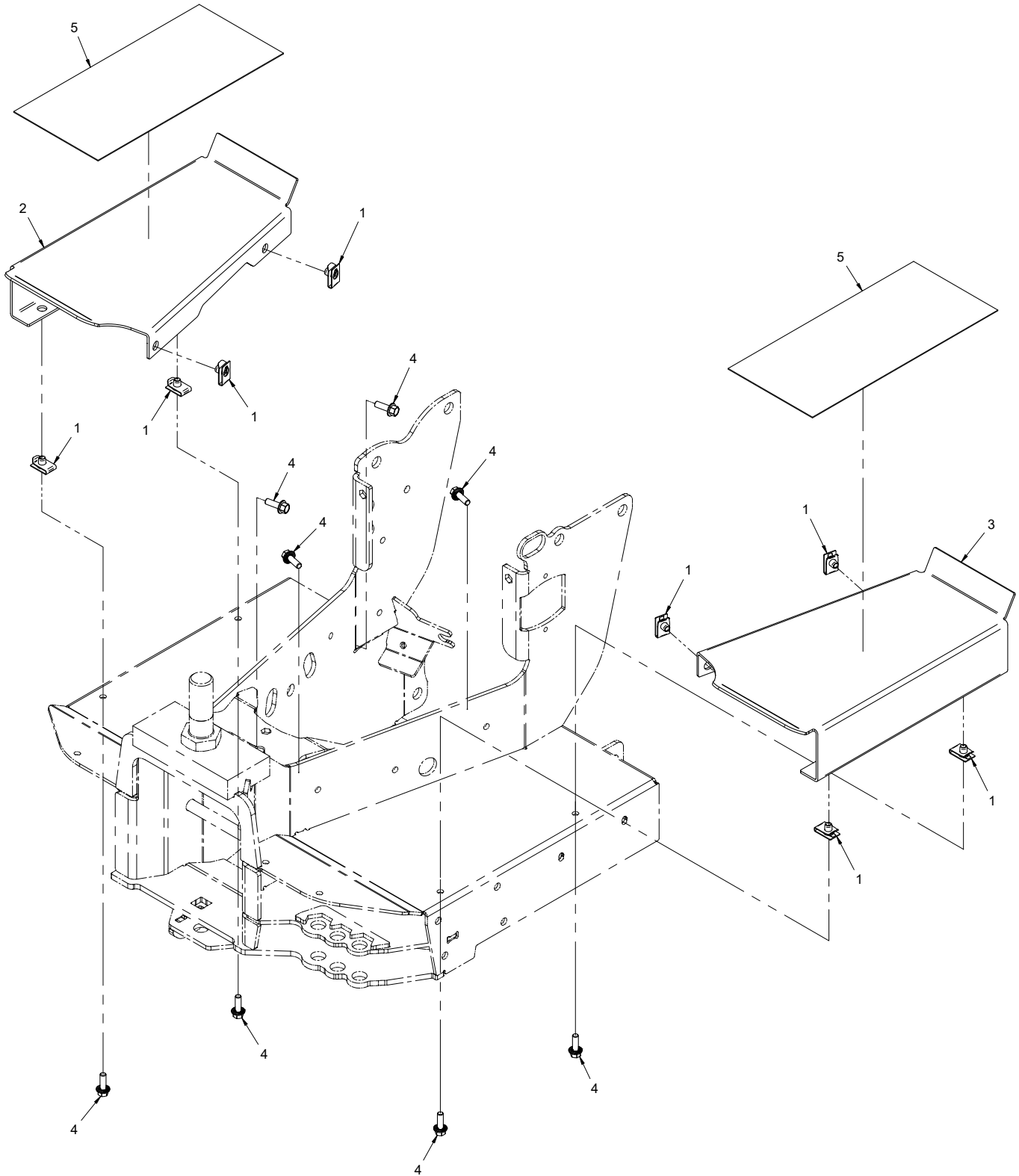

OPTIONS

70.4108 Raised Platform Kit

REF.	PART NO.	DESCRIPTION	QTY.
1	99.E0046	.NUT, "U" 1/4-20 EXTRUDED	8
2	62.1384	.FRAME, RAISED PLATFORM RH	1
3	62.1388	.FRAME, RAISED PLATFORM LH	1
4	99.SF0406	.BOLT, SRF 1/4-20 X 3/4	8
5	56.0055-11IN	.FLEX TREAD, 5" BLACK COARSE X 11"	2

OPTIONS

ILLUSTRATED DRAWING 70.4101 Backup Alarm Kit

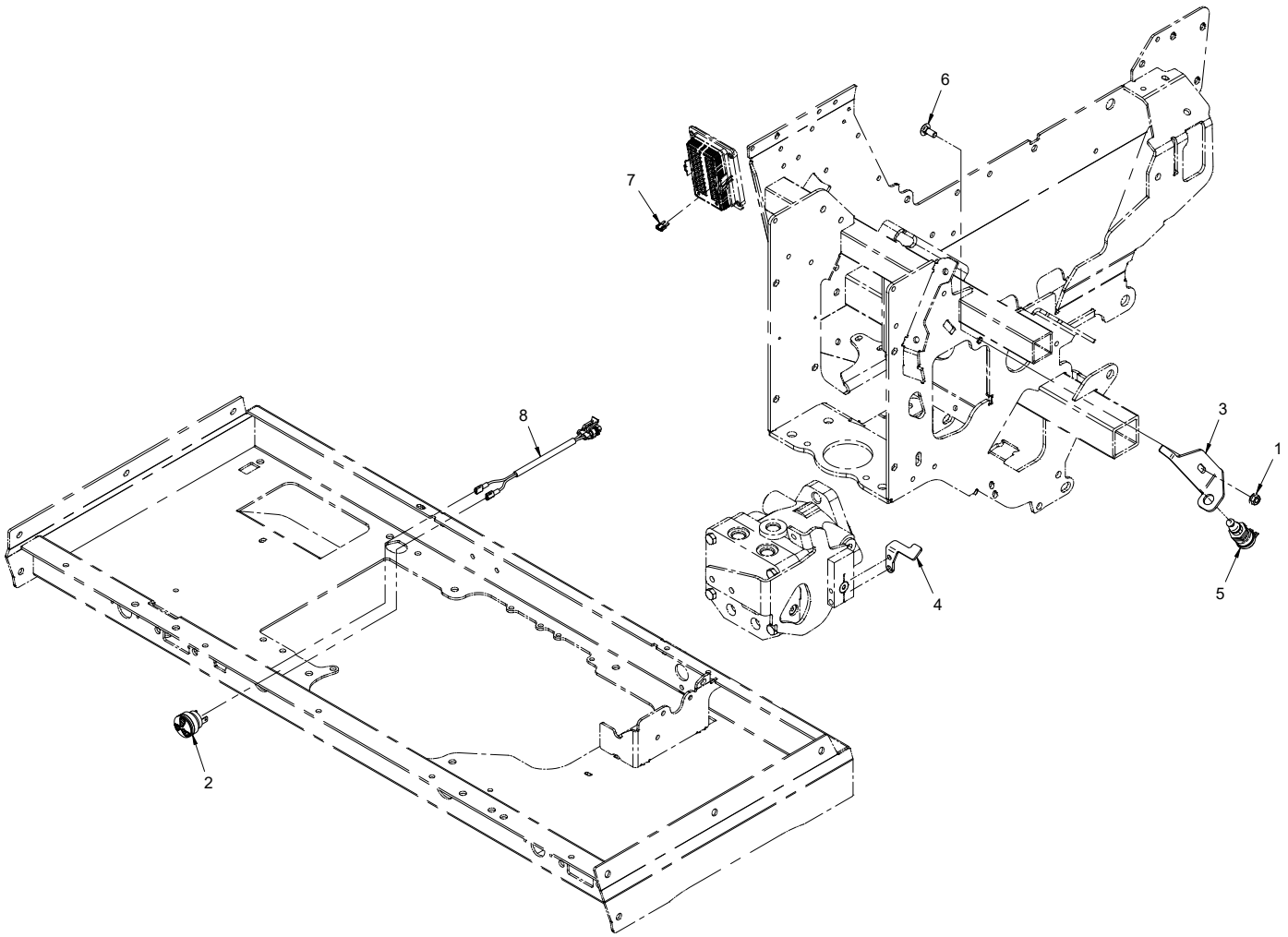

OPTIONS

70.4101 Backup Alarm Kit

REF.	PART NO.	DESCRIPTION	QTY.
1	99.SF05	.NUT, SRF 5/16-18 USS.	1
2	35.0125	.ALARM, AUDIBLE CONT. PANEL MT.	1
3	64.1601	.BRACKET, BACKUP SWITCH MOUNT	1
4	64.1600	.BRACKET, BACKUP SWITCH ACTUATOR.	1
5	31.0044	.SWITCH, PUSH BUTTON - NEUTRAL.	1
6	97.0506	.BOLT, CARRIAGE 5/16 X 3/4.	1
7	30.0333	.FUSE, 10 AMP MINI RED.	1
8	32.0122	.HARNESS, WIRE BACKUP ALARM.	1

OPTIONS

ILLUSTRATED DRAWING 70.4121 Front Hitch Lock Valve Kit

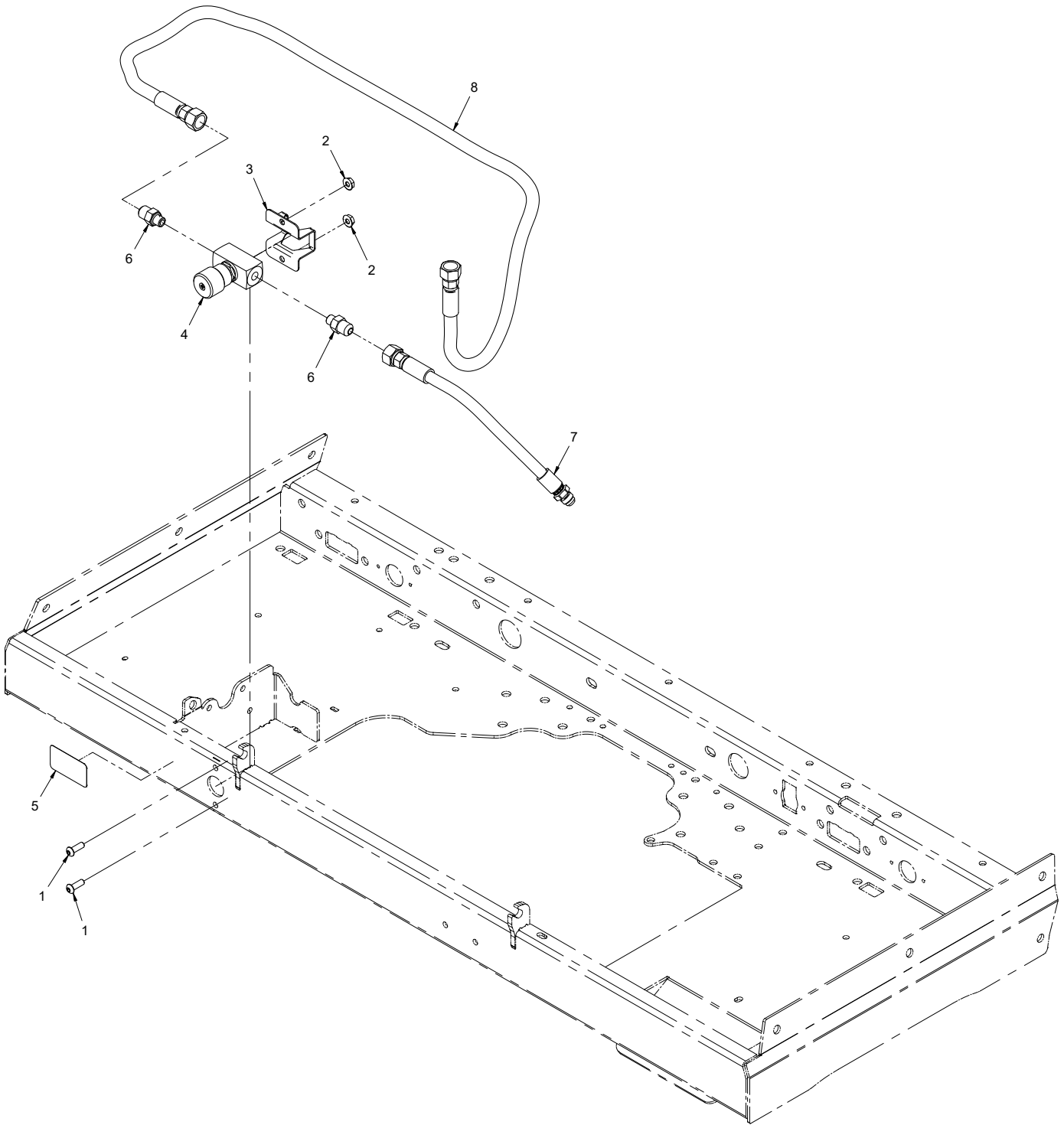

OPTIONS

70.4121 Front Hitch Lock Valve Kit

REF.	PART NO.	DESCRIPTION	QTY.
1	99.0406	.BOLT, 1/4-20 X 3/4 BSCS	2
2	99.SF04	.NUT, SRF 1/4-20 USS.	2
3	64.1719	.BRACKET, NEEDLE VALVE	1
4	23.0161	.VALVE, NEEDLE.	1
5	00.0329	.DECAL, FRONT HITCH VALVE.	1
6	25.6400-06-04	.FITTING, M CONN 3/8 X 1/4	2
7	20.0311	.HOSE, 1/4X8.00 SAE 100R17AR.	1
8	20.0302	.HOSE, 1/4X48.00 SAE 100R17 AR	1

OPTIONS

ILLUSTRATED DRAWING 70.4104 12 Volt Front Plug Kit

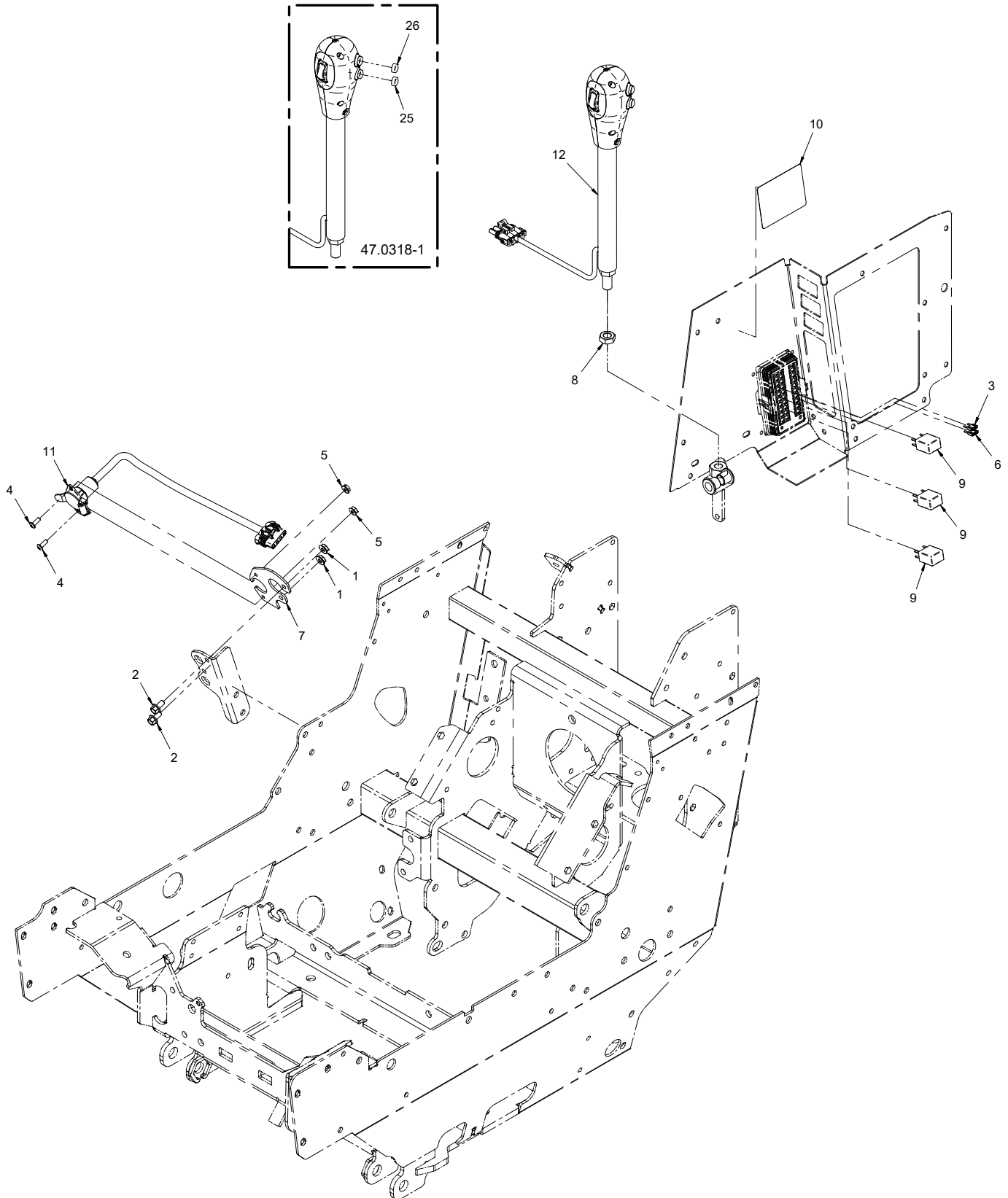

OPTIONS

70.4104 12 Volt Front Plug Kit

REF.	PART NO.	DESCRIPTION	QTY.
1	99.SF04	.NUT, SRF 1/4-20 USS.	2
2	99.SF0404-1	.BOLT, SMF 1/4-20 X 1/2	2
3	30.0332	.FUSE, 5 AMP MINI TAN	1
4	99.K0062	.MACHINE SCREW, #10-32 X 1/2	2
5	99.E0035	.NUT, SRF #10-32	2
6	30.0334	.FUSE, 15 AMP MINI BLUE.	1
7	64.1605	.BRACKET, 12V 4 PIN SOCKET MT	1
8	92.08	.NUT, JAM 1/2-13 USS.	1
9	35.0117	.RELAY, 12V 35/20 AMP 280 MICRO	3
10	00.0328	.DECAL, HANDLE 12V	1
11	32.0114	.HARNESS, WIRE 12V FRONT	1
12	47.0318-1	.HANDLE, SDLA GRIP & POST	1
25	47.0349	.BUTTON, SWITCH ORANGE (1/4" TALL)	1
25	47.0427	.BUTTON, SWITCH ORANGE (1/8" TALL)	1
26	47.0348	.BUTTON, SWITCH YELLOW (1/4" TALL)	1
26	47.0426	.BUTTON, SWITCH YELLOW (1/8" TALL)	1

OPTIONS

ILLUSTRATED DRAWING 70.4105 12 Volt Rear Plug Kit

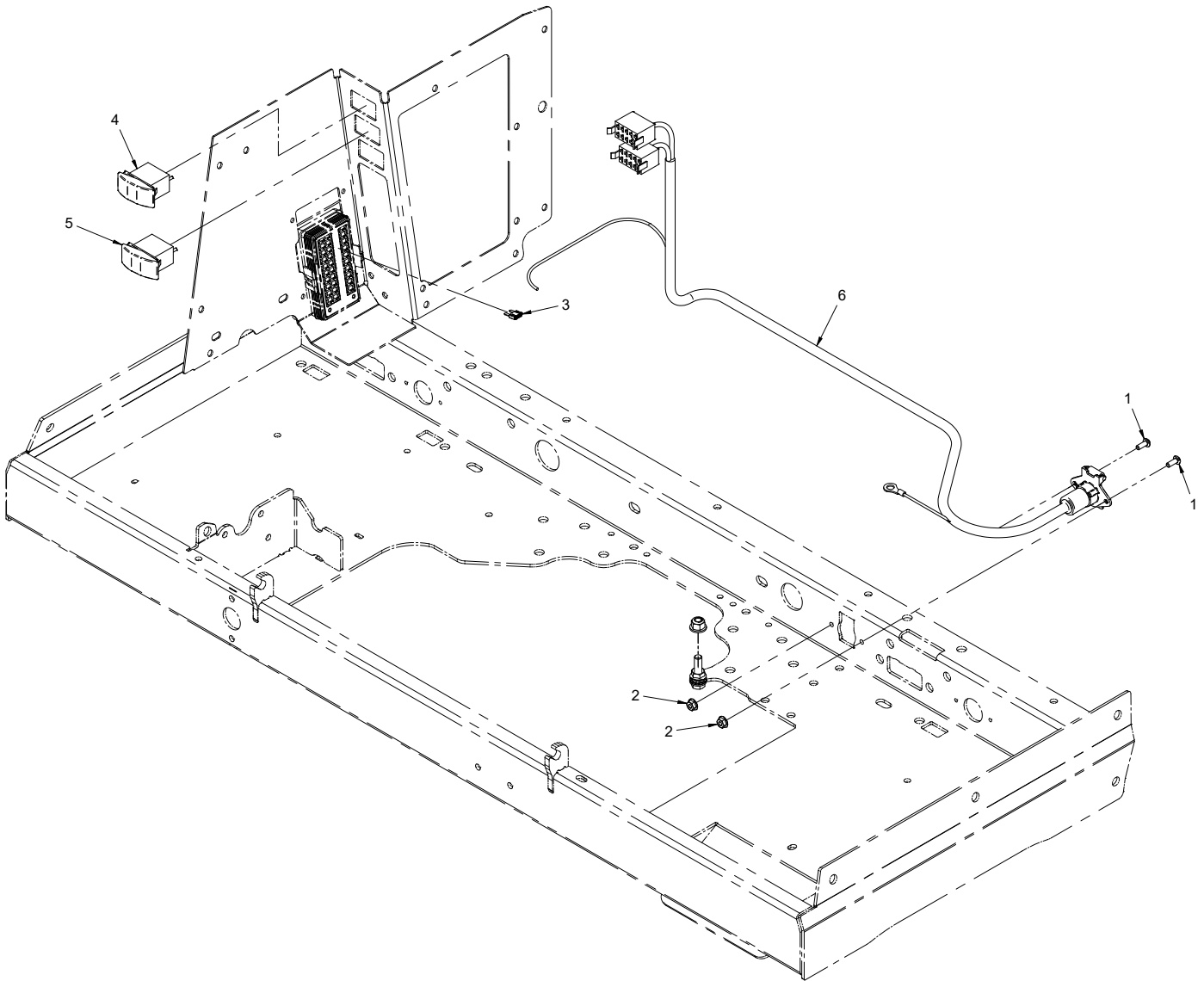

OPTIONS

70.4105 12 Volt Rear Plug Kit

REF.	PART NO.	DESCRIPTION	QTY.
1	99.K0062	.MACHINE SCREW, #10-32 X 1/2	2
2	99.E0035	.NUT, SRF #10-32	2
3	30.0335	.FUSE, 20 AMP MINI YELLOW	1
4	31.0053	.SWITCH, ROCKER ON/OFF	1
5	31.0056	.SWITCH, ROCKER (ON)/OFF/(ON)	1
6	32.0113	.HARNESS, WIRE 12V REAR	1

OPTIONS

ILLUSTRATED DRAWING 70.4106 PTO Remote Kit

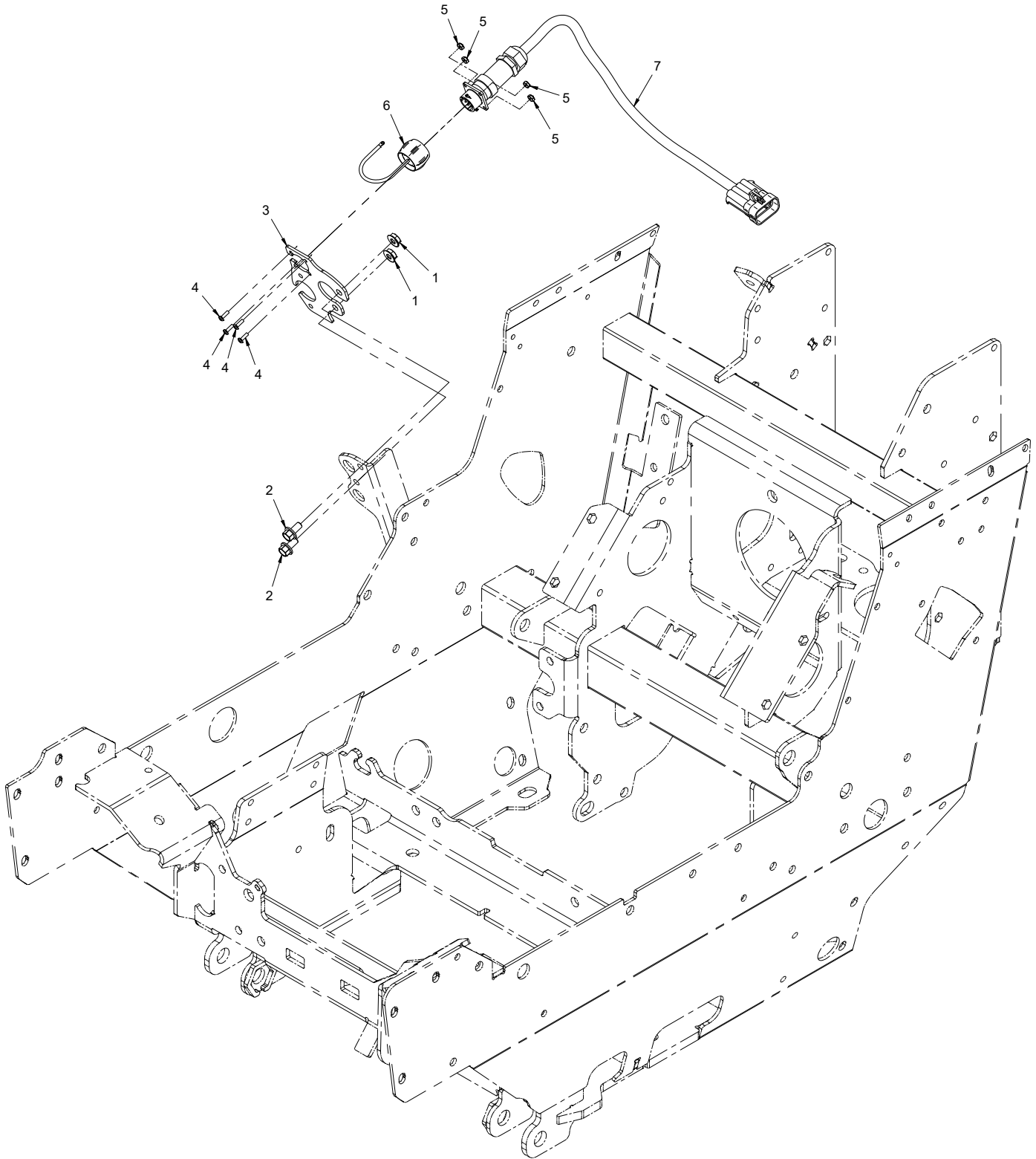

OPTIONS

70.4106 PTO Remote Kit

REF.	PART NO.	DESCRIPTION	QTY.
1	99.SF04	.NUT, SRF 1/4-20 USS.	2
2	99.SF0404-1	.BOLT, SMF 1/4-20 X 1/2	2
3	64.1607	.BRACKET, 12V DUAL SOCKETMOUNT	1
4	99.K0130	.MACHINE SCREW, #4-40 X 3/8.	4
5	99.E0110	.NUT, JAM #4-40 NYLON LOCK.	4
6	30.0441	.CAP, UTS MALE CONNECTOR	1
7	32.0121	.HARNESS, WIRE PTO REMOTE	1

OPTIONS

ILLUSTRATED DRAWING 70.4120 Horn Kit

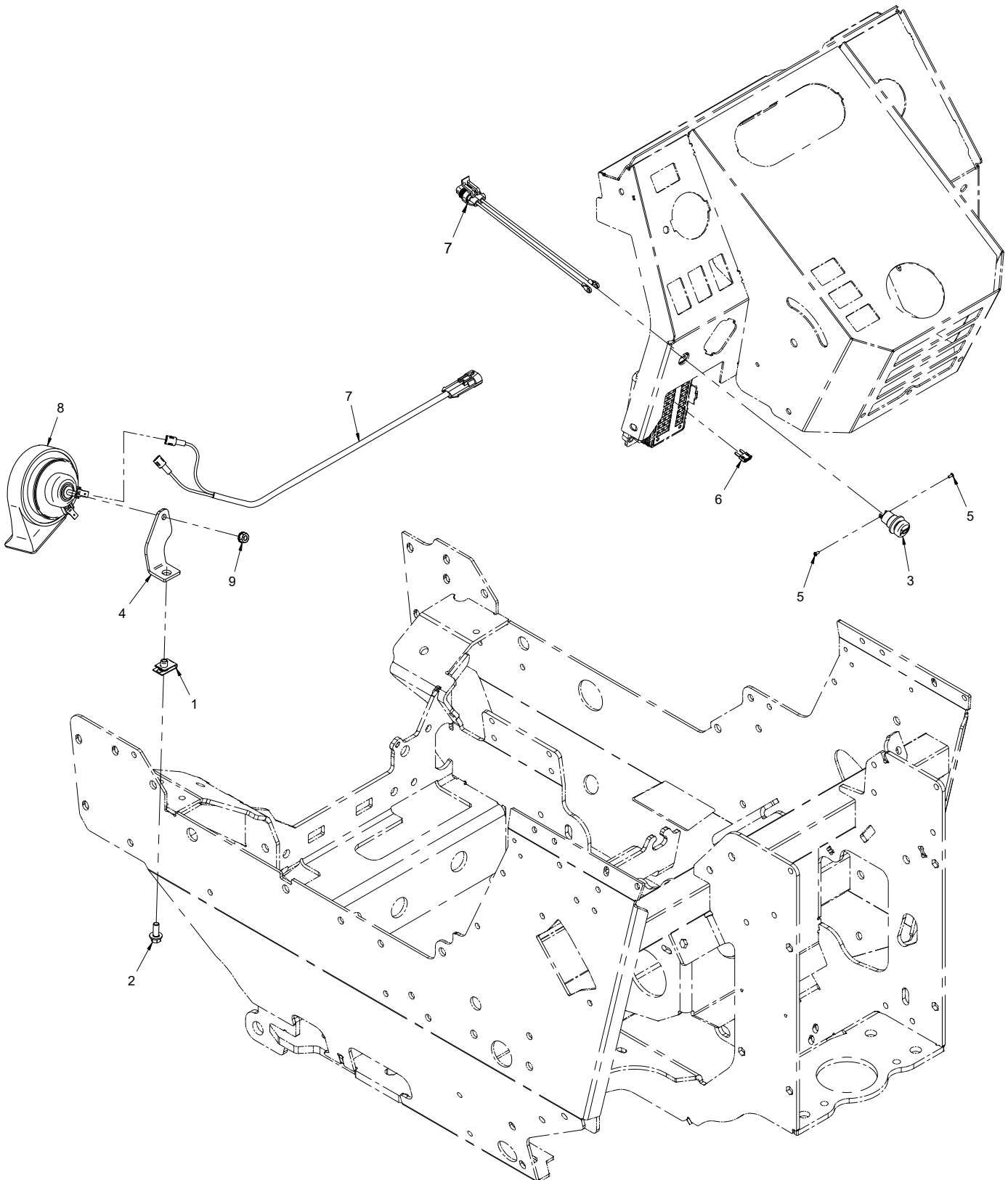

OPTIONS

70.4120 Horn Kit

REF.	PART NO.	DESCRIPTION	QTY.
1	99.E0046	.NUT, "U" 1/4-20 EXTRUDED	1
2	99.SF0405-1	.BOLT, SMF 1/4-20 X 5/8	1
3	31.0057	.SWITCH, HORN	1
4	64.1711	.BRACKET, HORN	1
5	99.K0125	.MACHINE SCREW, #2-56 X 3/16	2
6	30.0332	.FUSE, 5 AMP MINI TAN	1
7	32.0115	.HARNESS, WIRE HORN	1
8	33.0019	.HORN, LOW TONE	1
9	99.M0029	.NUT, M6 X 1.0 W/LOCK WASHER	1

OPTIONS

ILLUSTRATED DRAWING 70.4135 Slope Indicator Kit

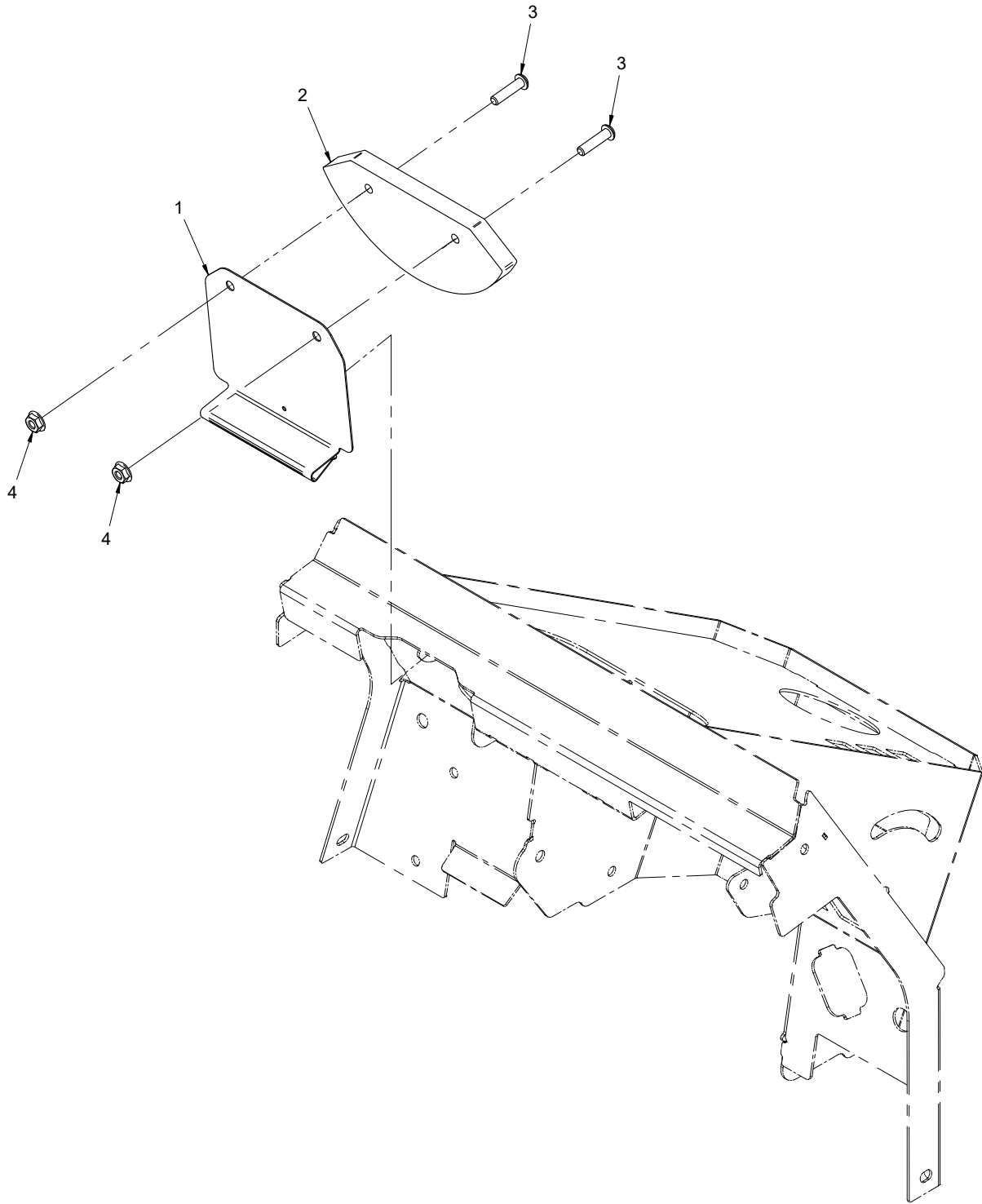

OPTIONS

70.4135 Slope Indicator Kit

REF.	PART NO.	DESCRIPTION	QTY.
1	64.1844	.BRACKET, SLOPE INDICATOR 4500	1
2	35.0105	.INDICATOR, SLOPE DEGREE	1
3	99.0408	.BOLT, 1/4-20 X 1 BSCS	2
4	99.SF04	.NUT, SRF 1/4-20 USS.	2

OPTIONS

ILLUSTRATED DRAWING 70.4109 Dual Front Hydraulic Auxiliary Kit

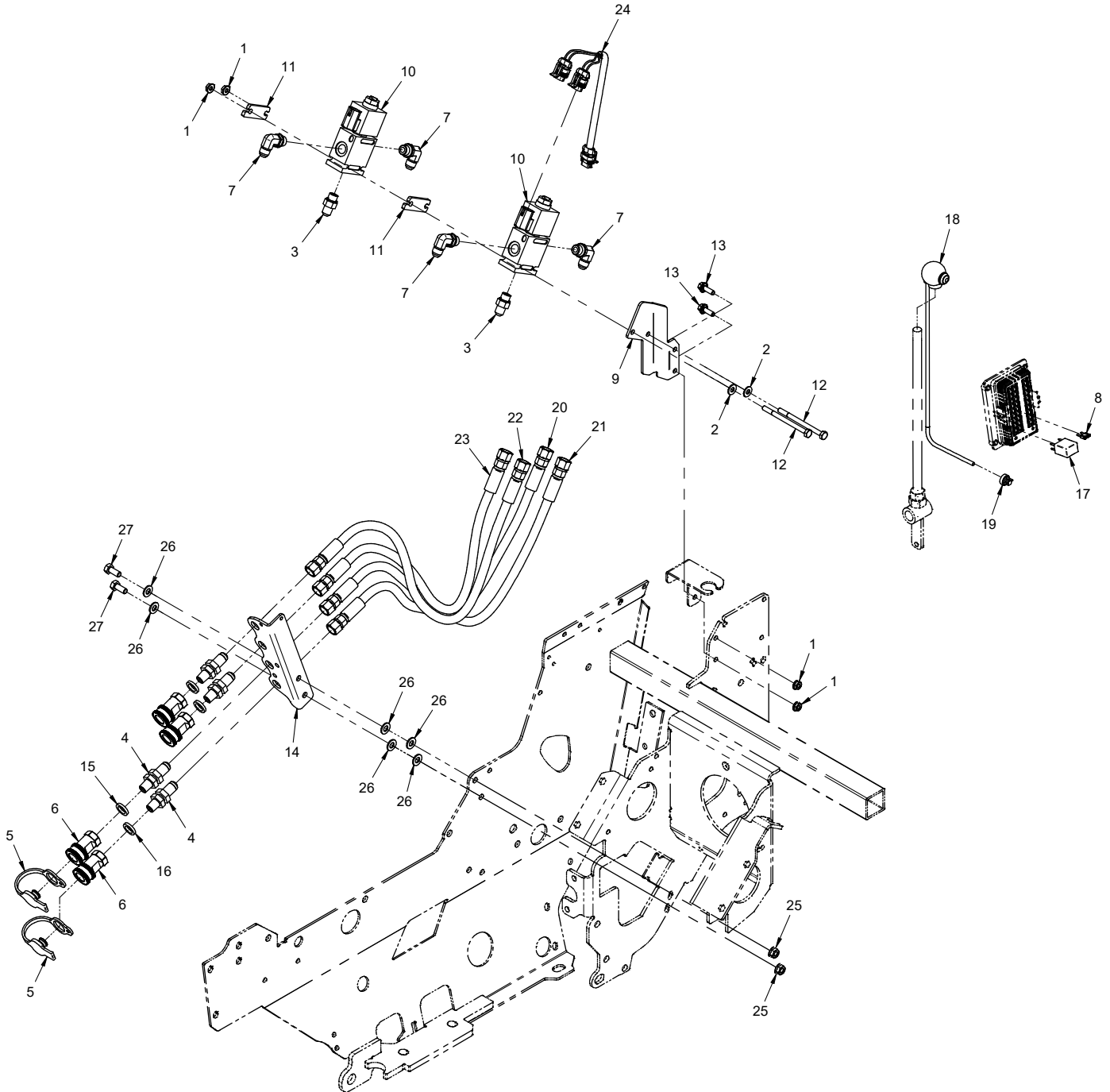

OPTIONS

70.4109 Dual Front Hydraulic Auxiliary Kit

REF.	PART NO.	DESCRIPTION	QTY.
1	99.SF04	.NUT, SRF 1/4-20 USS	4
2	95.04	.WASHER, FLAT 1/4 SAE	2
3	25.6400-06-06	.FITTING, M CONN 3/8 X 3/8	2
4	25.2706-04-06LN	.FITTING, BULKHEAD W/ LOCKNUT	2
5	23.0126	.PLUG, DUST FOR 23.0106	2
6	23.0106	.COUPLER, HYDRAULIC QUICK - 1/4 FEMALE	2
7	25.6801-06-06	.FITTING, 90 ME 3/8 X 3/8	4
8	30.0333	.FUSE, 10 AMP MINI RED	1
9	64.1650	.BRACKET, DUAL VALVE MOUNT	1
10	23.0164	.VALVE, DIRECTIONAL 12V	2
11	64.1649	.PLATE, SPACER HYD VALVE	2
12	90.0428	.BOLT, 1/4-20 USS X 3-1/2"	2
13	99.SF0406-1	.BOLT, SMF 1/4-20 X 3/4	2
14	64.1602	.BRACKET, HYD COUPLER 4 POS	1
15	05.0156	.WASHER, .544ID X .817 X 14 NAT	1
16	05.0157	.WASHER, .544 X .817 X 14 BLK	1
17	35.0117	.RELAY, 12V 35/20 AMP 280 MICRO	1
18	47.0336	.HANDLE, GRIP W/SWITCH	1
19	30.0037	.TYTON TIE, #50 .18 X 8 BLACK	2
20	20.0306	.HOSE, 1/4X25.00 SAE 100R17 AR	1
21	20.0306	.HOSE, 1/4X25.00 SAE 100R17 AR	1
22	20.0306	.HOSE, 1/4X25.00 SAE 100R17 AR	1
23	20.0306	.HOSE, 1/4X25.00 SAE 100R17 AR	1
24	32.0120	.HARNESS, WIRE DUAL HYDRAULIC	1
25	99.SF05	.NUT, SRF 5/16-18 USS	2
26	95.05	.WASHER, FLAT 5/16 SAE	6
27	90.0506	.BOLT, 5/16-18 USS X 3/4"	2

OPTIONS

ILLUSTRATED DRAWING Dual Front Hydraulic Auxiliary Diagram

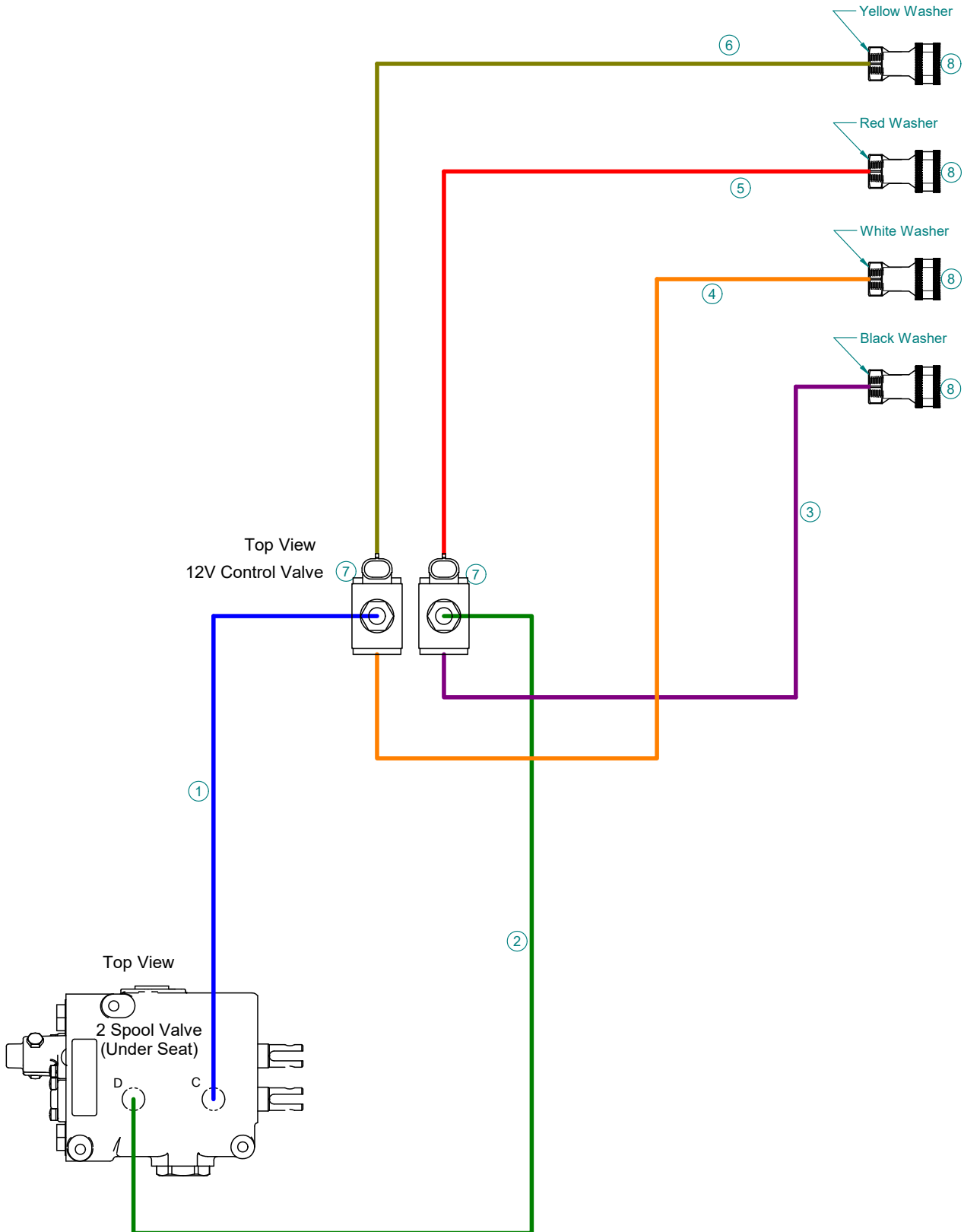

OPTIONS

Dual Front Hydraulic Auxiliary Diagram

REF.	PART NO.	DESCRIPTION	QTY.
1	20.0303	.HOSE, 1/4X58.00 SAE 100R17 AR	1
2	20.0303	.HOSE, 1/4X58.00 SAE 100R17 AR	1
3	20.0306	.HOSE, 1/4X25.00 SAE 100R17 AR	1
4	20.0306	.HOSE, 1/4X25.00 SAE 100R17 AR	1
5	20.0306	.HOSE, 1/4X25.00 SAE 100R17 AR	1
6	20.0306	.HOSE, 1/4X25.00 SAE 100R17 AR	1
7	23.0164	.VALVE, DIRECTIONAL 12V	2
8	23.0106	.COUPLER, HYDRAULIC QUICK - 1/4 FEMALE	4

OPTIONS

ILLUSTRATED DRAWING 70.4140 Slope Indicator Kit

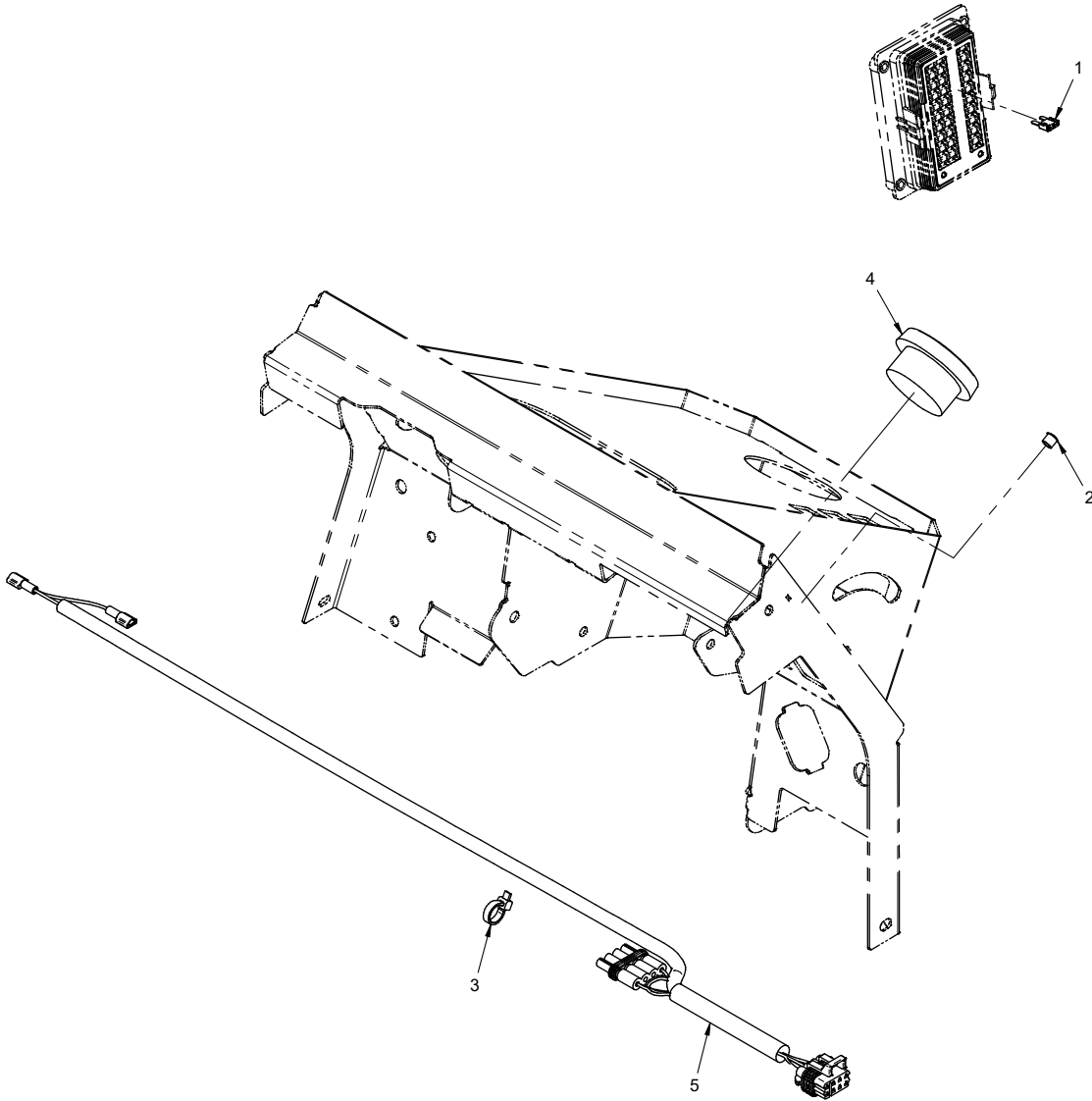

OPTIONS

70.4140 Slope Indicator Kit

REF.	PART NO.	DESCRIPTION	QTY.
1	30.0332	.FUSE, 5 AMP MINI TAN	1
2	05.0147	.PLUG, 5/16" HOLE, NYLON BLACK	1
3	30.0037	.TYTON TIE, #50 .18 X 8 BLACK	4
4	35.0145	.GAUGE, SLOPE INDICATOR	1
5	32.0166	.HARNESS, WIRE SLOPE INDICATOR	1

OPTIONS

ILLUSTRATED DRAWING 39.56114 3N1 Hitch

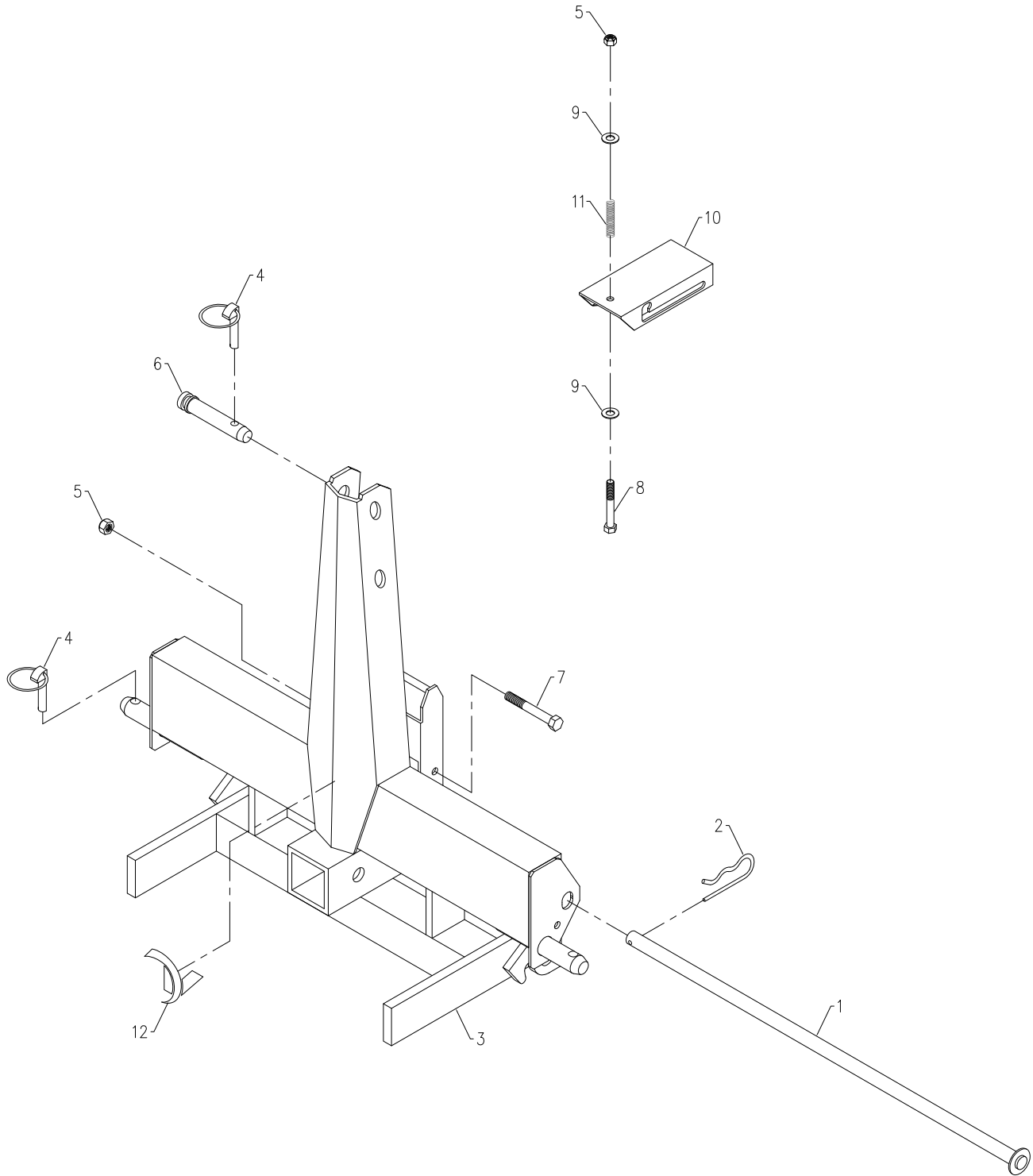

OPTIONS

39.56114 3N1 Hitch

REF.	PART NO.	DESCRIPTION	QTY.
1	64.1017	.PIN, SECURE WEIGHTS 5/8 X 24"L	1
2	02.HP0420	.HAIRPIN, 1/8 X 2 1/2	1
3	62.0925	.FRAME, 3N1 TOW HITCH	1
4	03.0005	.PIN, LINCH	3
5	99.A05	.LOCKNUT, STOVER 5/16-18 USS	2
6	03.0004	.PIN, TOP LINK CATEGORY 1	1
7	90.0526	.BOLT, 5/16-18 USS X 3-1/4	1
8	90.0524	.BOLT, 5/16-18 USS X 3	1
9	95.05	.WASHER, FLAT 5/16 SAE	2
10	64.1101	.LATCH, LEVER LOCK	1
11	41.0021	.SPRING, COMP 1/2 OD X 2-3/4 LG	1
12	00.0192	.DECAL, V-DECAL DIE CUT BLUE	1

OPTIONS

ILLUSTRATED DRAWING 39.56116 Rear Counterweight Bar

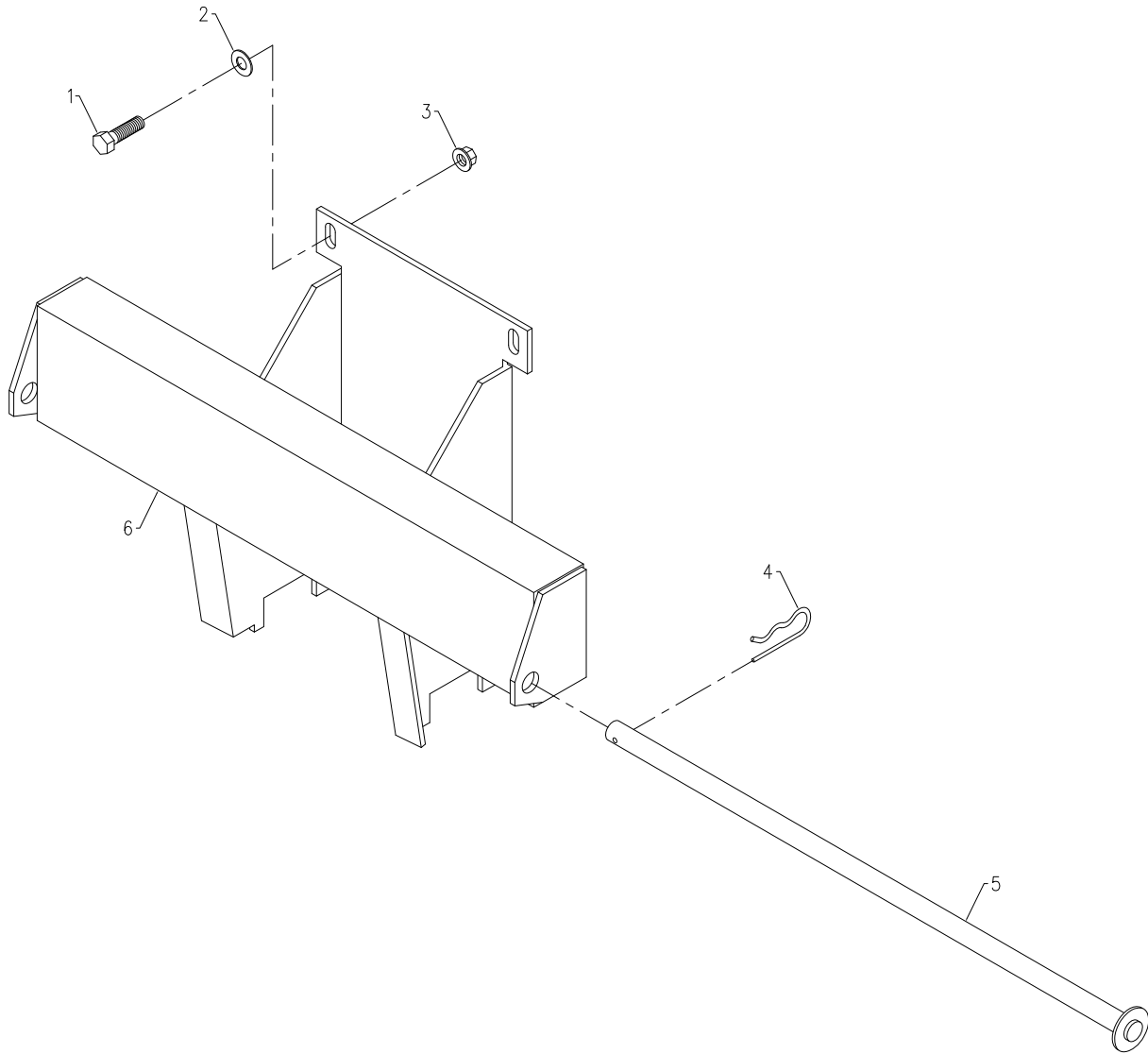

OPTIONS

39.56116 Rear Counterweight Bar

REF.	PART NO.	DESCRIPTION	QTY.
1	90.0606	.BOLT, 3/8-16 USS X 3/4	2
2	95.06	.WASHER, FLAT 3/8 SAE	2
3	99.SF06	.NUT, SRF 3/8-16 USS	2
4	02.HP0420	.HAIRPIN, 1/8 X 2 1/2	1
5	64.1040	.PIN, WEIGHT SECURE 21"L	1
6	62.0955	.FRAME, REAR WT BRACKET	1

OPTIONS

ILLUSTRATED DRAWING 70.4137 Mid Weight Bar 4500 Kit

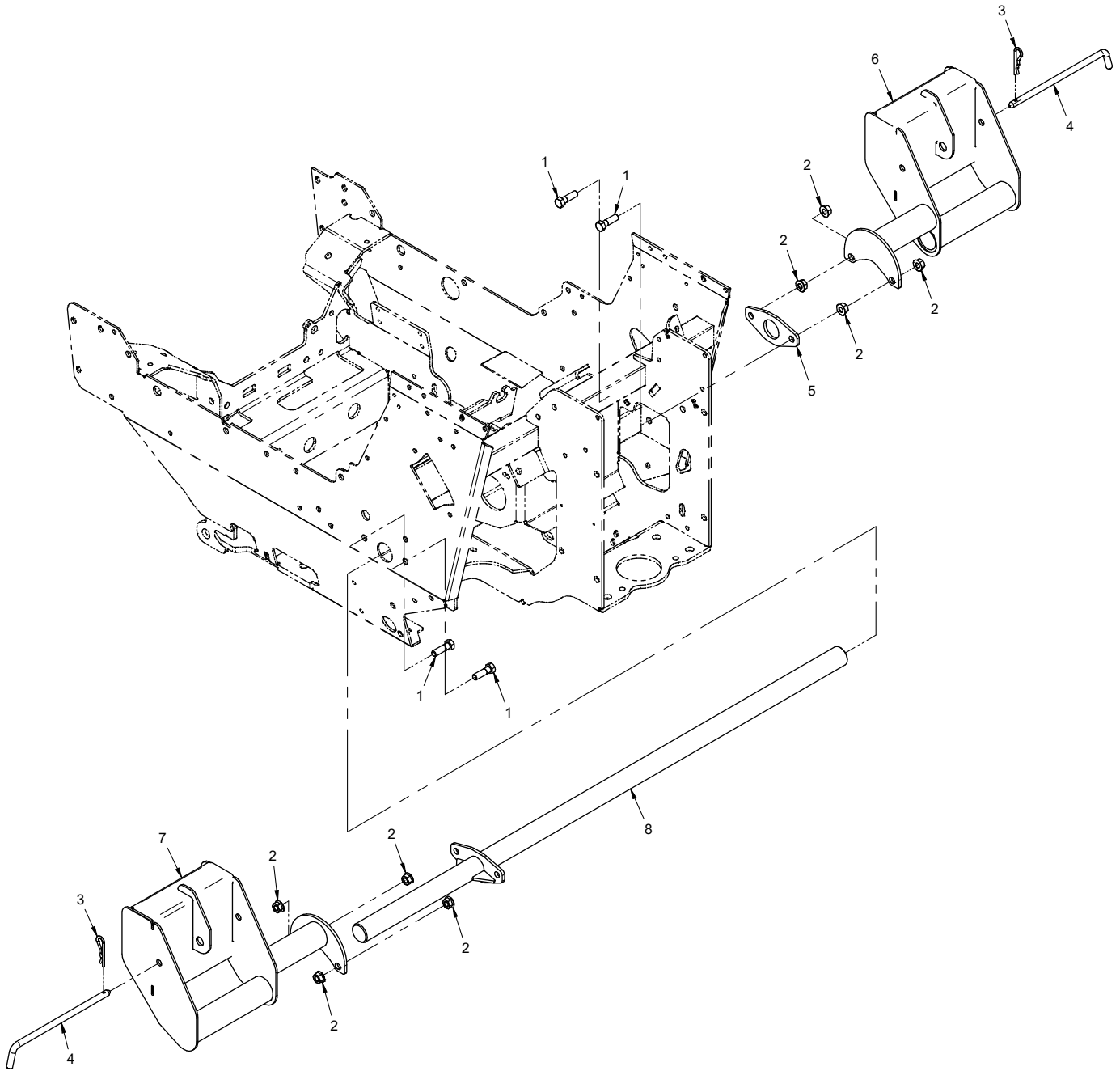

OPTIONS

70.4137 Mid Weight Bar 4500 Kit

REF.	PART NO.	DESCRIPTION	QTY.
1	90.0610	.BOLT, 3/8-16 USS X 1-1/4.	4
2	99.SF06	.NUT, SRF 3/8-16 USS.	8
3	02.HP0416	.HAIRPIN, 1/8 X 2.	2
4	64.0761	.PIN, WEIGHT SECURE 7.3" USABLE	2
5	64.1029	.PLATE, REAR CLAMP CROSSBAR MT.	1
6	62.1449	.FRAME, WEIGHT MID RIGHT.	1
7	62.1448	.FRAME, WEIGHT MID LEFT.	1
8	42.0455	.SHAFT, REAR ANCHOR MOUNT.	1

OPTIONS

ILLUSTRATED DRAWING 70.4144 Rear Weight Bar Kit

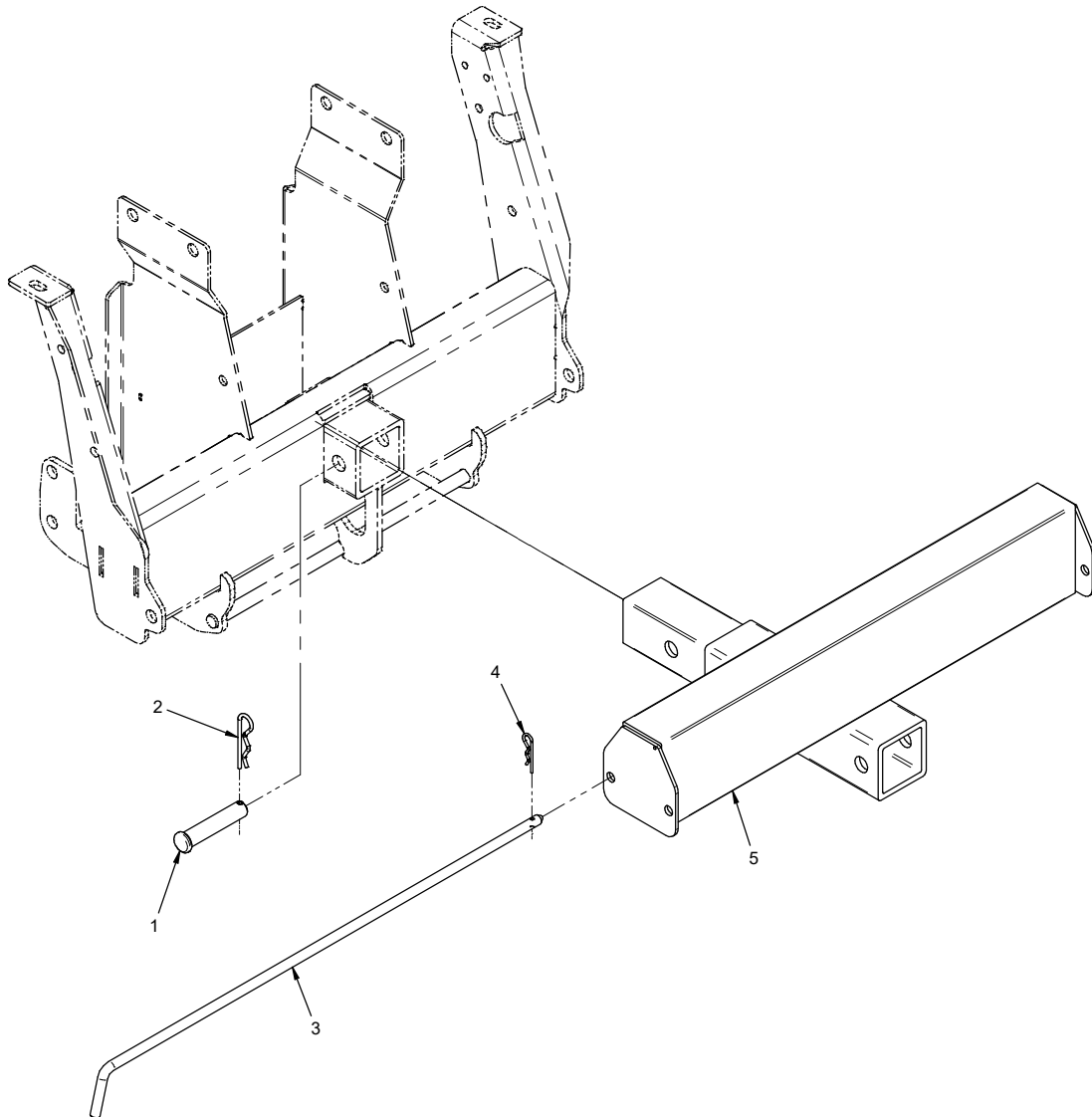

OPTIONS

70.4144 Rear Weight Bar Kit

REF.	PART NO.	DESCRIPTION	QTY.
1	03.1024	.CLEVIS PIN, 5/8 X 3 OAL	1
2	02.HP0420	.HAIRPIN, 1/8 X 2 1/2	1
3	64.1912	.PIN, WEIGHT SECURE 22.5" USABLE	1
4	02.HP0313	.HAIRPIN, 3/32 X 1-5/8	1
5	62.1454	.FRAME, REAR WEIGHT BAR	1

OPTIONS

ILLUSTRATED DRAWING 70.4133 LED Work Light Kit

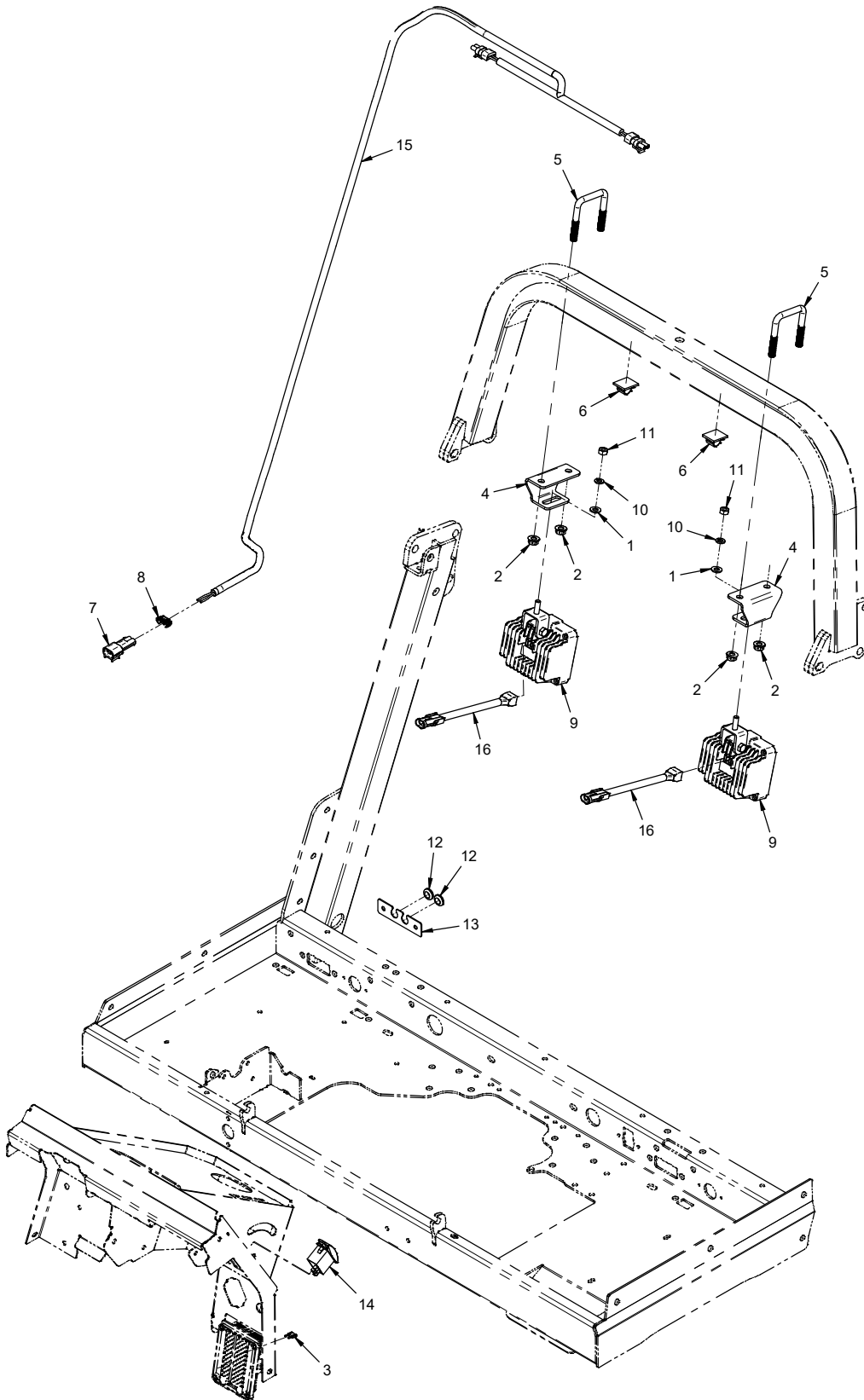

OPTIONS

70.4133 LED Work Light Kit

REF.	PART NO.	DESCRIPTION	QTY.
1	95.05	.WASHER, FLAT 5/16 SAE	2
2	99.E0082	.NUT, LOCKING FLANGE 3/8-16	4
3	30.0334	.FUSE, 15 AMP MINI BLUE	1
4	64.1706	.BRACKET, WORKLIGHT MOUNT KN	2
5	11.0053	.U-BOLT, 3/8-16 2-1/16 ID SQ.	2
6	30.0217	.CLAMP, WIRE MT ADH. 1/2 GRAY	2
7	30.0322	.CONNECTOR, MP280 2 POS MALE	1
8	30.0326	.CLIP, MP280 CONNECTOR 2 POS.	1
9	33.0069	.LIGHT, WORK 3 X 3 LED	2
10	96.05	.WASHER, LOCK 5/16	2
11	99.M0025	.NUT, M8 X 1.25M	2
12	05.0136	.GROMMET, 7/16ID, 3/4OD, 1/4THK	2
13	60.1175	.COVER, OPT. LIGHT KIT ACCESS	1
14	31.0053	.SWITCH, ROCKER ON/OFF	1
15	32.0116	.HARNESS, WIRE WORK LIGHT.	1
16	32.0162	.HARNESS, WIRE 33.0069 WP	2

OPTIONS

ILLUSTRATED DRAWING 70.2016 Trailer Mover Hitch

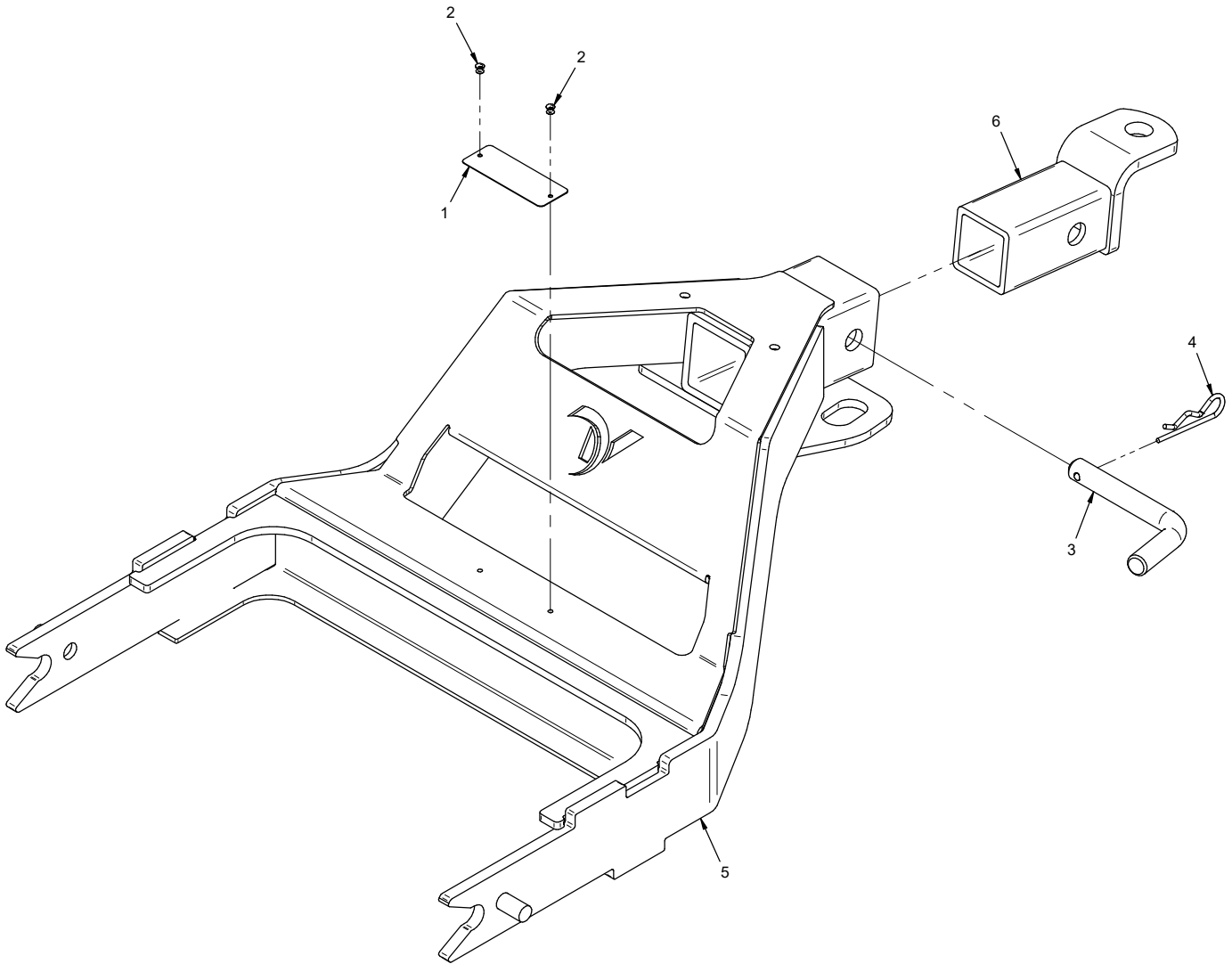

OPTIONS

70.2016 Trailer Mover Hitch

REF.	PART NO.	DESCRIPTION	QTY.
1	N/A	.PLATE, VENTRAC SERIAL NUMBER	1
2	04.0007	.RIVET, POP DOME 1/8 X 1/8 S.S.	2
3	03.0014	.PIN, HITCH 5/8" X 3" USABLE	1
4	02.HP0420	.HAIRPIN, 1/8 X 2 1/2	1
5	62.1461	.FRAME, TOW HITCH	1
6	62.0968	.HITCH, REAR	1