

Parts Manual

3400Y

Europe C€

Serial Number 3400Y-AL01001 --



Revised 08/23/23
09.20015 Rev. 25



500 Venture Drive
Orrville Oh 44667
www.ventrac.com



Visit ventrac.com/manuals for the latest version of this operator's manual.

A downloadable parts manual is also available.

Serial Number Description

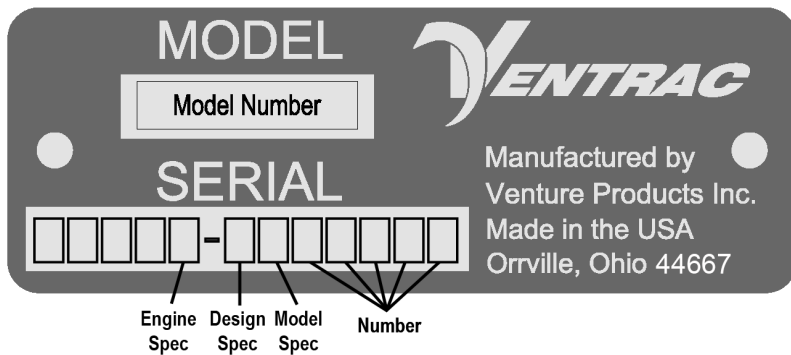

ENGINE

Y KUBOTA 25 HP D902 DSL LC

Notes

- If any component requires replacement, use only original Ventrac replacement parts.
- When ordering new components, be sure to order all required safety decals. All current safety decals must be affixed to the replacement components prior to installation of the component.

TABLE OF CONTENTS

ELECTRICAL	PAGE 5
Wiring Diagram - Rear Harness	6
Wiring Diagram - Front Harness	7
Wiring Diagram - Engine Harness.....	8
Wiring Diagram - Optional 30.0219 4-Pin Female Socket & 30.0218 4-Pin Male Plug.....	9
Tractor Control Module	10
Battery, Power Cables, & Ground Cables	12
Front Fuse Panel & Wire Harness Shields.....	14
Rear Fuse Panel	16
Power Relay Module	18
RPM Sensor	20
Speedometer Sensor	22
HYDRAULICS	PAGE 24
Hydraulic Diagram.....	24
O-Ring Chart	26
Hydraulic Charge Pressure Circuit.....	28
Hydraulic Oil Tank	30
Hydraulic Steering System.....	32
Front Hitch Hydraulic Lift.....	34
Auxiliary Hydraulic Quick Couplers	36
ENGINE	PAGE 38
Engine	38
Engine Mount	40
Throttle Control	42
Exhaust System	44
Cooling System	46
Air Intake	48
Fuel System	50
AXLES, WHEELS, & DRIVE SYSTEMS	PAGE 52
Front Transaxle Mount & Tires	52
51.0061 Front Transaxle	54
Rear Transaxle Mount & Tires.....	56
51.0060 Rear Transaxle.....	58
Belt & Pulley Diagram	60
Main Drive From Engine	62
Center Drive Shaft & Clutch	64
Center Drive Shaft Shields.....	66
Transaxle Drive	68
PTO Drive	70

TABLE OF CONTENTS

FRAMES / SHEET METAL	PAGE 72
Rear Frame, Fenders, and Engine Side Panels	72
Hood Base Mount & Support Panels	74
Top & Rear Hood Panels.....	76
Left Hood Panel	78
Right Hood Panel	80
Center Frame Pivot & Connector Link	82
Front Frame & Step.....	84
Steering Column	86
Right Dash Panel & SDLA Cover	88
Front Hitch.....	90
Weight Transfer.....	92
Roll Bar	94
Seat Assembly	96
 CONTROLS & LINKAGE	 PAGE 98
SDLA Control Levers.....	98
SDLA Linkage	100
Foot Pedal.....	102
Parking Brake.....	104
 OPTIONS	 PAGE 106
70.3044 Work Light Kit.....	106
70.3045 Strobe Light Kit.....	108
70.3046 Directional / Hazard Light Kit.....	110
70.3037 Backup Alarm Kit.....	112
70.3036 12 Volt Front Kit.....	114
70.3050 12 Volt Rear Kit	116
70.3041 Horn Kit	118
70.3039 Dual Front Hydraulic Auxiliary Kit.....	120
Dual Front Hydraulic Auxiliary Diagram	122
70.3040 Suspension Seat Kit.....	124
70.2016 Trailer Mover Hitch	126

ELECTRICAL

ILLUSTRATED DRAWING Wiring Diagram Reference Key

Wire Reference Key

Harness Section Identifier

A = 32.0130 - Harness, Front
B = 32.0131 - Harness, Rear
C = 32.0132 - Harness, Kubota Diesel
D = 32.0133 - Harness, B&S Engine
E =
F =
G = 32.0148 - Harness, Kit - 12v Front
H = 32.0156 - Harness, Kit - 12v Rear
J = 32.0151 - Harness, Kit - 12v Dual Hydraulic
K = 32.0150 - Harness, Kit - PTO Remote
L = 32.0152 - Harness, Kit - Horn
M = 32.0149 - Harness, Kit - Backup Alarm
N = 32.0155 - Harness, Kit - Directional
P = 32.0154 - Harness, Kit - Strobe Light
R = 32.0153 - Harness, Kit - Work Light

----- = *Black Wire
————— = White Wire
||| ——— = Ground
● = Splice or Connection

* All black wires that are part of the wire harness are part of the ground circuit. However, some components such as lights may be wired where black may be positive.

All other wires colors are as shown

Anything outlined with a blue box is a Standard Feature

Anything outlined with a Green box is a Option

Wire Color & Circuit Type

Black = Ground
Dark Blue = Pre-Heat
Lt Blue = Safety Circuit
Brown = Engine Run / Kill
Gray = 12v Aux / Horn power
Green = Start/Speed/Directional
Lt Green = 12 Aux
Orange = Propane / Slope
Pink = Alarm
Purple = PTO
Red = Power
Tan = RPM
White = Power
Yellow = Light/Directional

ELECTRICAL

ILLUSTRATED DRAWING Wiring Diagram - Rear Harness

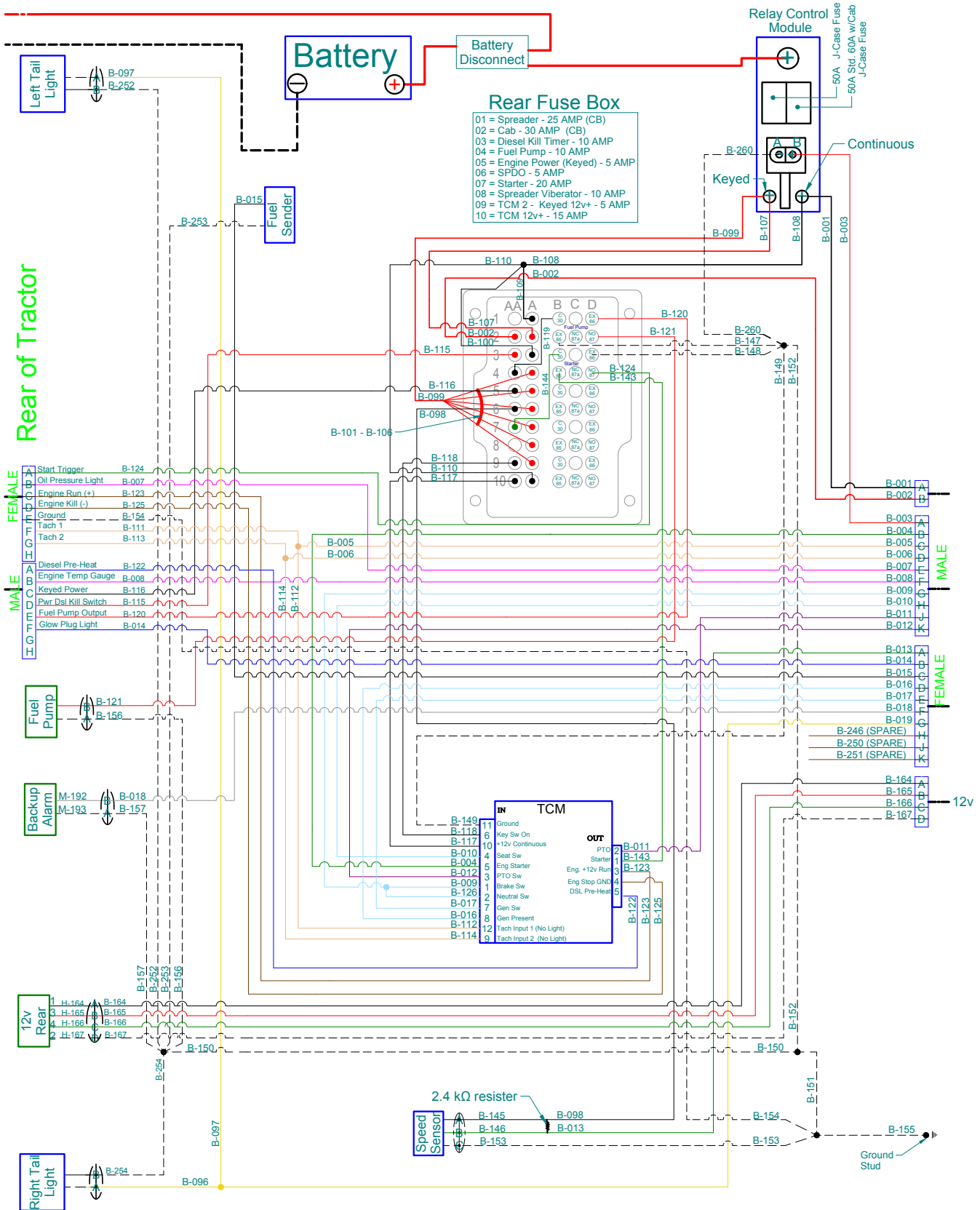

ELECTRICAL

ILLUSTRATED DRAWING Wiring Diagram - Front Harness

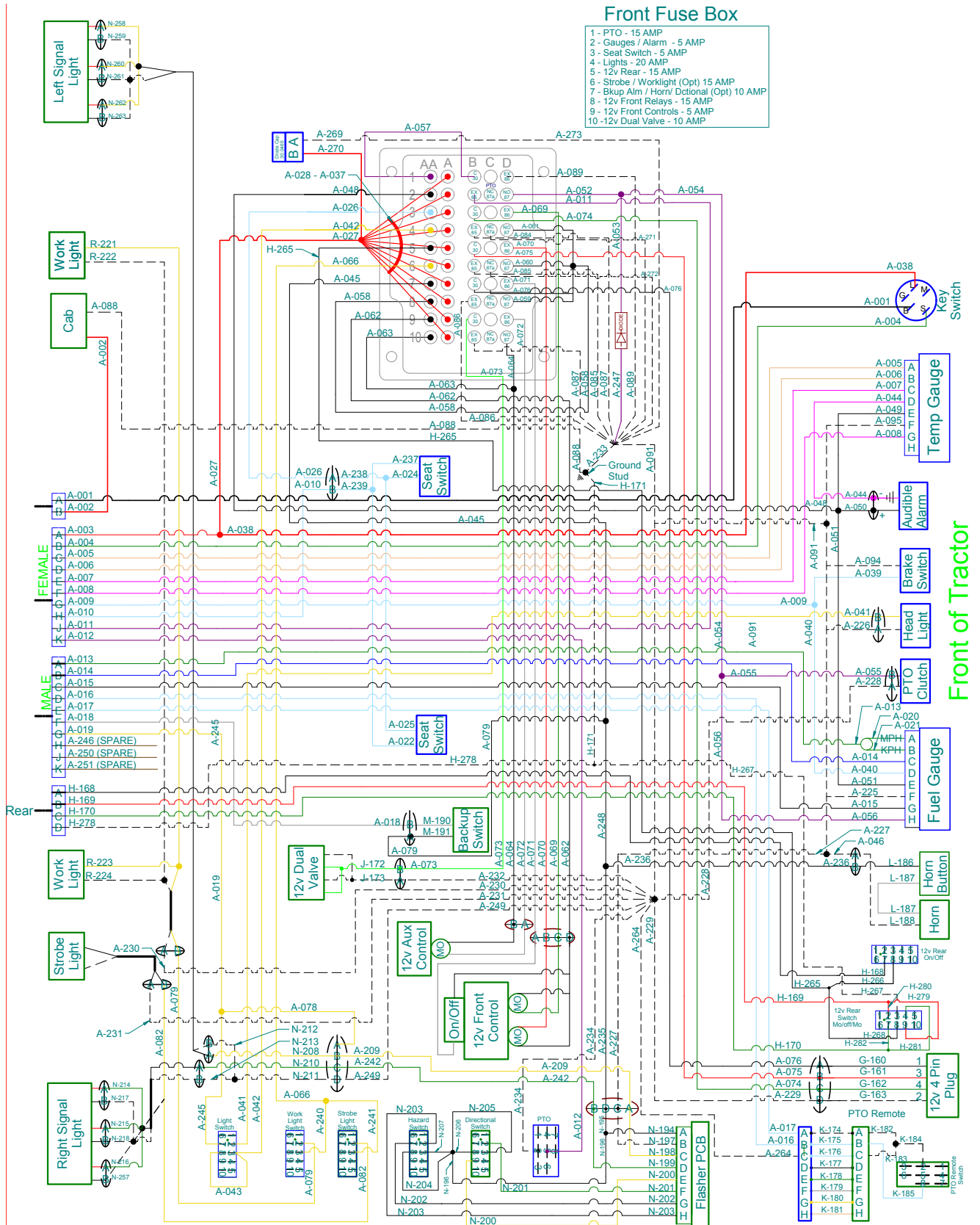

ELECTRICAL

ILLUSTRATED DRAWING Wiring Diagram - Engine Harness

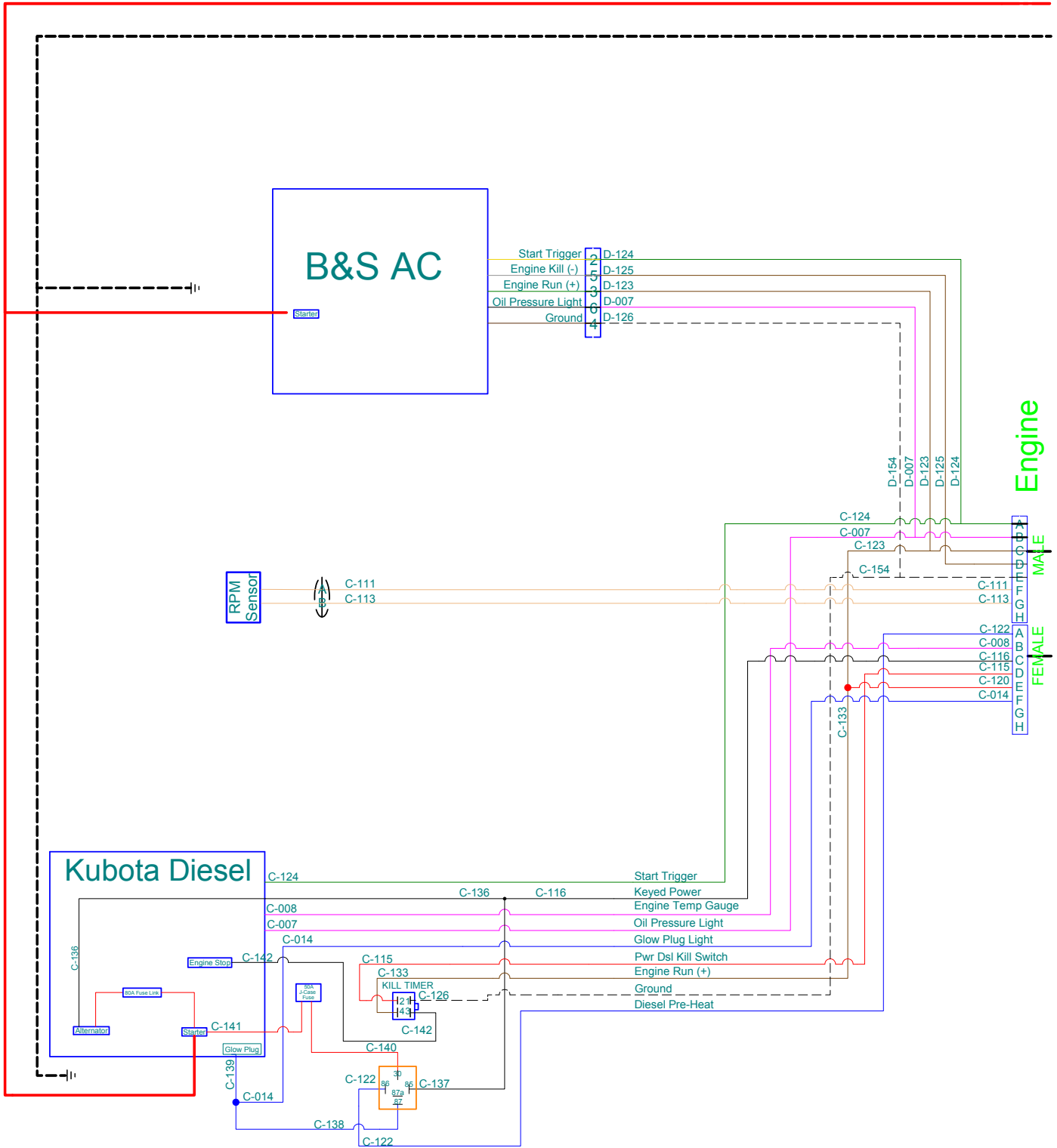

ELECTRICAL

Wiring Diagram - Optional 30.0219 4-Pin Female Socket & 30.0218 4-Pin Male Plug



Attention

This connector (4-pin socket) is designed for use with Ventrac original equipment only. This connector (4-pin socket) is rated for 20 amp maximum current draw. Engine alternator and/or battery capacity determine allowable continuous draw.

30.0219 4-pin female socket is used in the 70.3036 12 Volt Front kit & 70.3050 12 Volt Rear Kit.

Front View of Socket
Without Cover

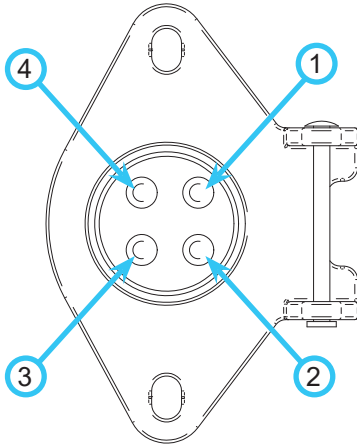

Rear View of Socket

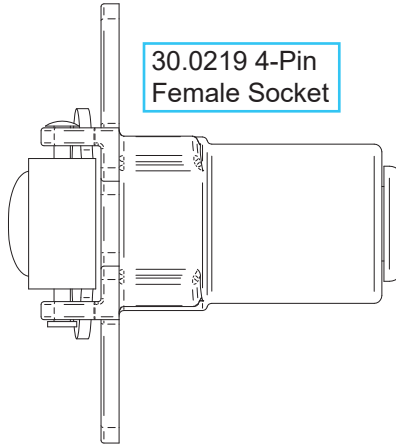
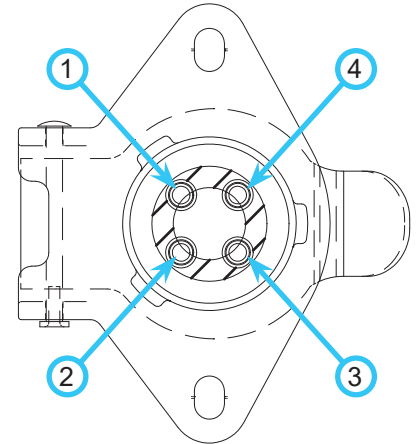

Terminal Position	Wire Color	Function
1	White	Positive (On/Off Switched)
2	Black	Negative (Constant)
3	Red	Positive/Negative (Momentary Switched Reversing)
4	Green or Brown	Positive/Negative (Momentary Switched Reversing)

30.0218 4-pin plug is used on attachments to connect to the 30.0219 socket on the power unit.

Front View of Plug

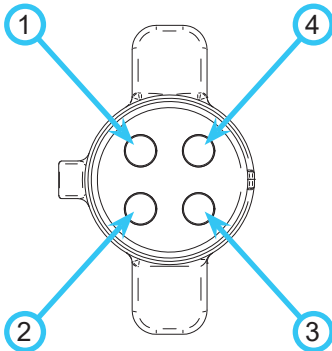

Rear View of Plug

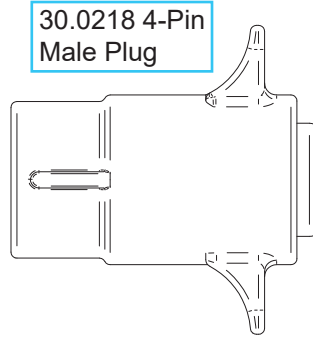
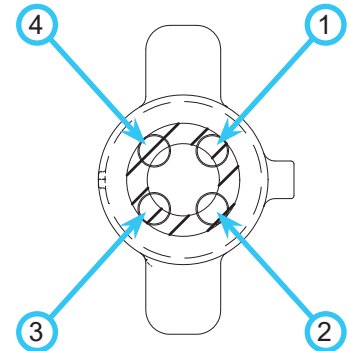

Terminal Position	Wire Color	Function
1	Not Specified*	Positive (On/Off Switched)
2	Not Specified*	Negative (Constant)
3	Not Specified*	Positive/Negative (Momentary Switched Reversing)
4	Not Specified*	Positive/Negative (Momentary Switched Reversing)

* Refer to the part diagram in the attachment's operator's manual for specific wire color and terminal position for each model.

ELECTRICAL

ILLUSTRATED DRAWING Tractor Control Module

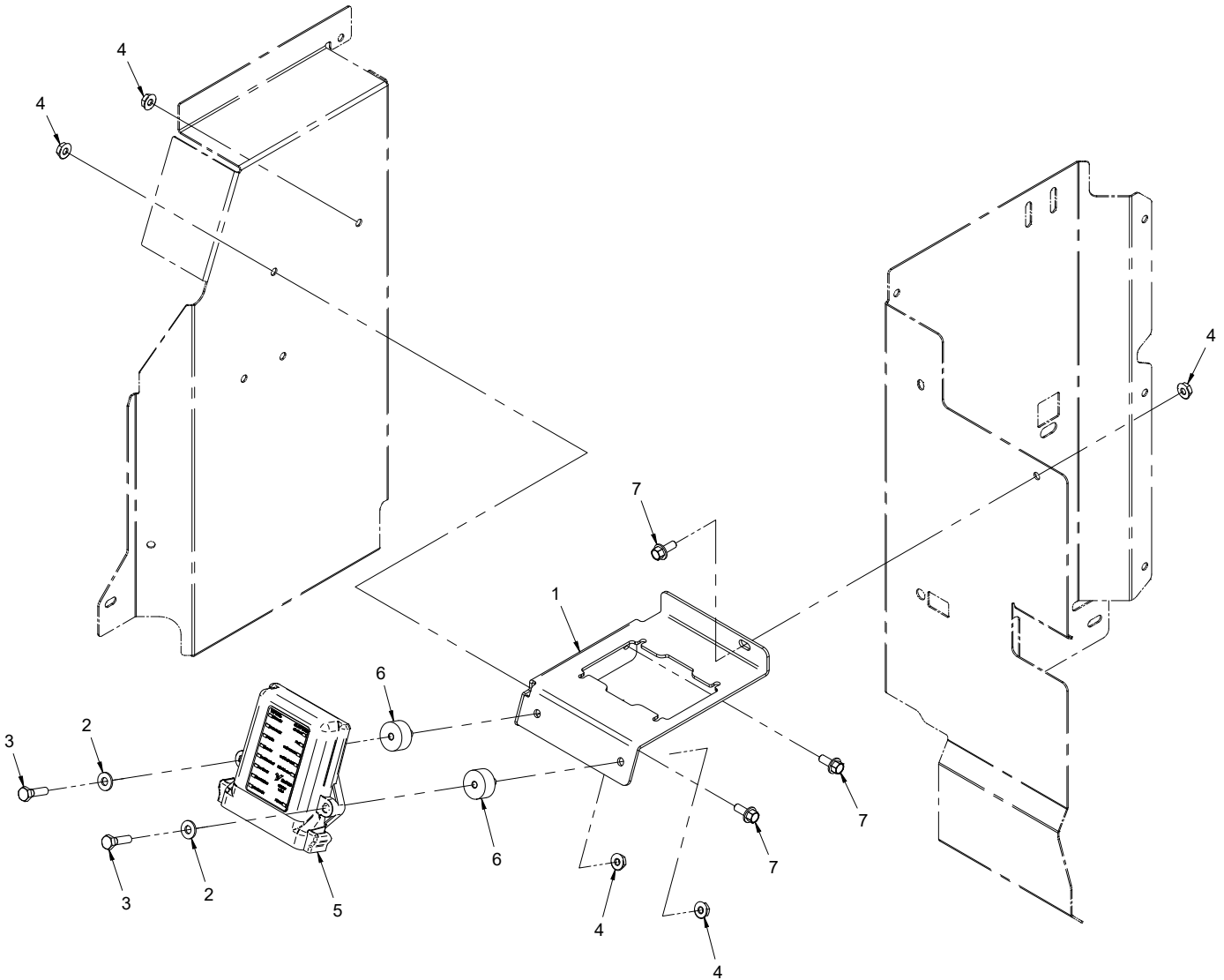

ELECTRICAL

Tractor Control Module

REF.	PART NO.	DESCRIPTION	QTY.
1	64.1758	.MOUNT, FUSE PANEL	1
2	95.04	.WASHER, FLAT 1/4 SAE	2
3	90.0408	.BOLT, 1/4-20 USS X 1"	2
4	99.SF04	.NUT, SRF 1/4-20 USS	5
5	35.0128	.MODULE, TRACTOR CONTROL (Serial # 01001-01158)	1
5	35.0146	.MODULE, TRACTOR CONTROL (Serial # 01159-01320)	1
5	35.0134	.MODULE, TRACTOR CONTROL (Serial # 01321-)	1
6	05.0135	.ISOLATOR, 1/4-20 X 1/2 X 1" F/M	2
7	99.SF0405-1	.BOLT, SMF 1/4-20 X 5/8	3

ELECTRICAL

ILLUSTRATED DRAWING Battery, Power Cables, & Ground Cables

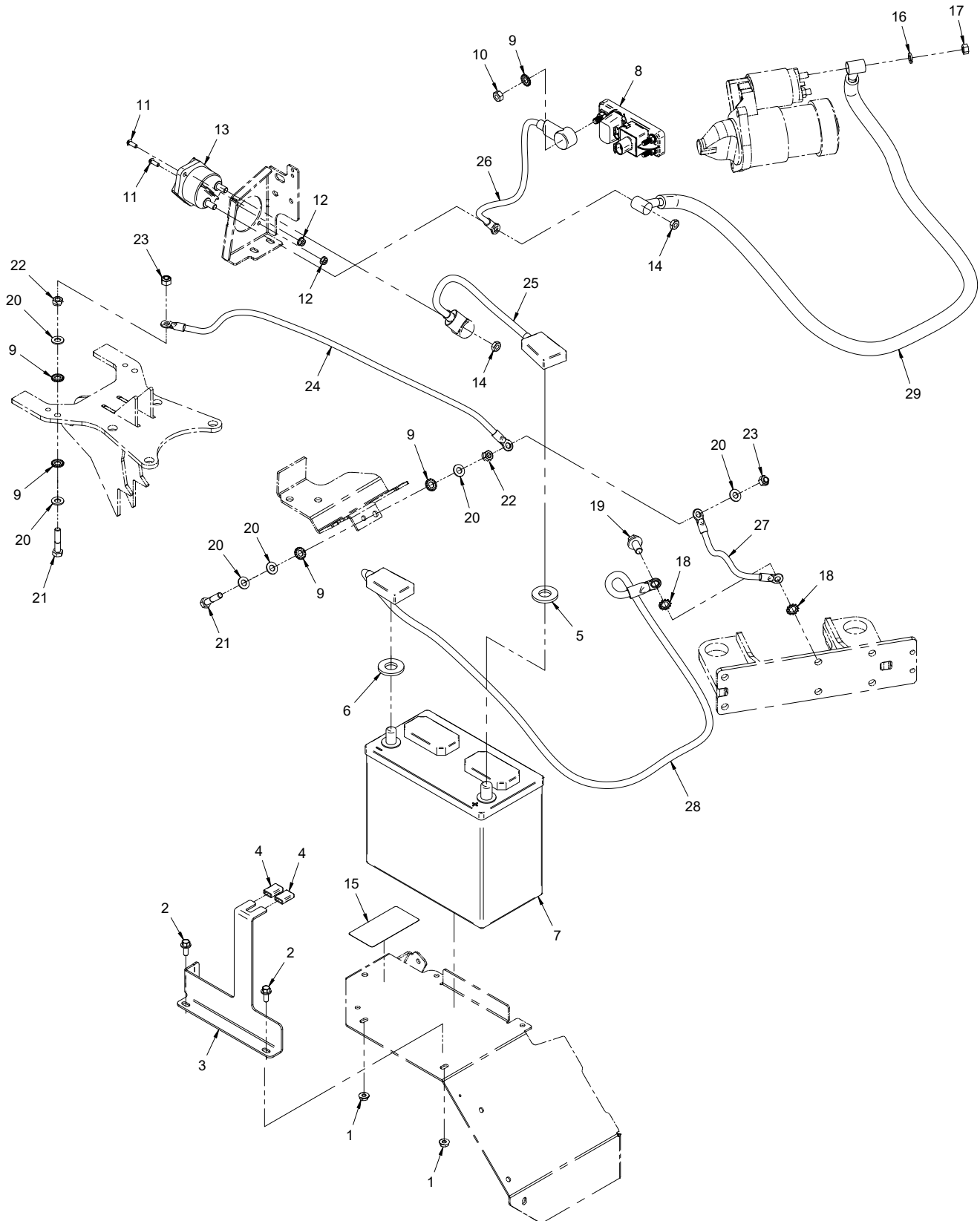

ELECTRICAL

Battery, Power Cables, & Ground Cables

REF.	PART NO.	DESCRIPTION	QTY.
1	99.SF04	.NUT, SRF 1/4-20 USS.	2
2	99.SF0405-1	.BOLT, SMF 1/4-20 X 5/8	2
3	64.1763	.BRACKET, BATTERY MOUNT	1
4	06.0044	.CAP, PLASTIC 1/8 X 1/2 X 7/8	2
5	05.0121	.WASHER, ANTI CORROSION RED	1
6	05.0122	.WASHER, ANTI CORROSION BLACK	1
7	33.0060	.BATTERY, GROUP 51R	1
8	30.0339	.MODULE, POWER RELAY	1
9	99.G0003	.WASHER, STAR-EXTERNAL 5/16	5
10	99.M0008	.NUT, M8 X 1.25MM ZP	1
11	99.K0062	.MACHINE SCREW, #10-32 X 1/2	2
12	99.E0035	.NUT, SRF #10-32	2
13	30.0338	.BREAKER, CIRCUIT 150 AMP	1
14	99.E0060	.NUT, JAM 5/16-18 USS	2
15	00.0366	.DECAL, WARNING BATTERY	1
16	13.04512-60080	.WASHER, SPRING LOCK	1
17	13.02156-50080	.NUT, HEX	1
18	99.G0004	.WASHER, STAR-EXTERNAL 3/8	2
19	99.M0028	.BOLT, M10-1.25 X 20MM FLANGE	1
20	95.05	.WASHER, FLAT 5/16 SAE	6
21	90.0512	.BOLT, 5/16-18 USS X 1-1/2"	2
22	99.SF05	.NUT, SRF 5/16-18 USS	2
23	99.A05N	.LOCKNUT, NYLON 5/16-18 USS	2
24	32.0140	.CABLE, ASM NEG 6 GA.	1
25	32.0136	.CABLE, ASM POS BATTERY 4GA	1
26	32.0139	.CABLE, ASM POS 6 GA.	1
27	32.0141	.CABLE, ASM NEG 6 GA.	1
28	32.0137	.CABLE, ASM NEG BATTERY 4 GA.	1
29	32.0142	.CABLE, ASM POS 4 GA.	1

ELECTRICAL

ILLUSTRATED DRAWING Front Fuse Panel & Wire Harness Shields

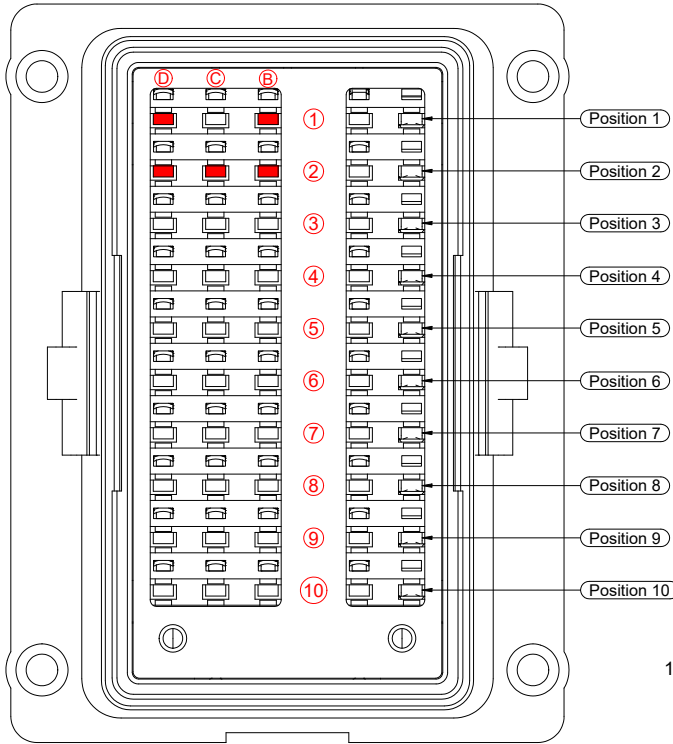

Ref. # / Position	Circuit
1	PTO
2	Gauges & Alarm
3	Seat Switch
4	Head / Tail Lights
5*	12v Rear
6*	Work / Strobe Lights
7*	Backup Alarm / Horn / Direction Lights
8*	12v Front Relays
9*	12v Front Controls
10*	Hydraulic Auxiliary

*Optional Accessory

Reference 16 relay is installed in Position 1 - 2 as referenced by shaded ports. The relay must be oriented with the single center pin down.

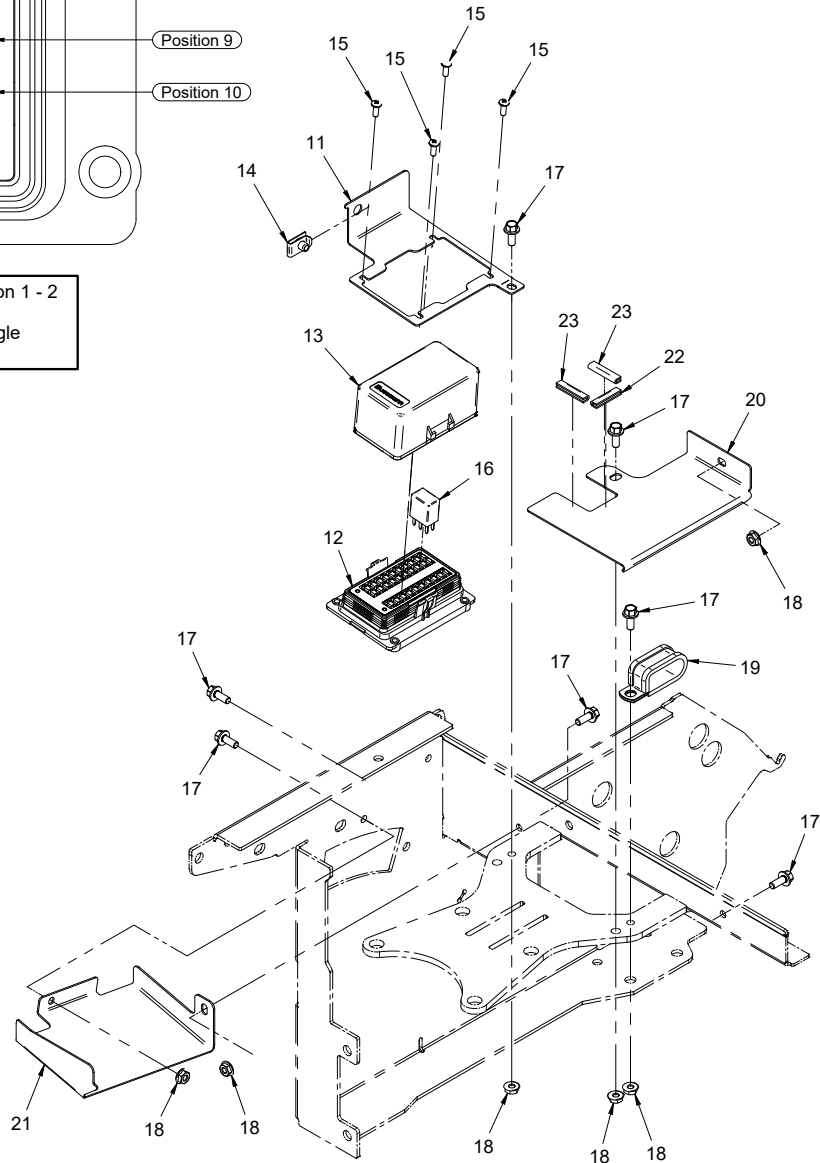

ELECTRICAL

Front Fuse Panel & Wire Harness Shields

REF.	PART NO.	DESCRIPTION	QTY.
1	30.0334	.FUSE, 15 AMP MINI BLUE	1
2	30.0332	.FUSE, 5 AMP MINI TAN	1
3	30.0332	.FUSE, 5 AMP MINI TAN	1
4	30.0334	.FUSE, 15 AMP MINI BLUE	1
5	30.0335	.FUSE, 20 AMP MINI YELLOW	1
6	30.0334	.FUSE, 15 AMP MINI BLUE	1
7	30.0333	.FUSE, 10 AMP MINI RED	1
8	30.0334	.FUSE, 15 AMP MINI BLUE	1
9	30.0332	.FUSE, 5 AMP MINI TAN	1
10	30.0333	.FUSE, 10 AMP MINI RED	1
11	64.1782	.BRACKET, FUSE PANEL MOUNT	1
12	30.0356	.FUSE PANEL, MINI NON-BUSSED	1
13	30.0331	.COVER, FUSE PANEL 30.0329	1
14	99.E0046	.NUT, "U" 1/4-20 EXTRUDED	1
15	99.K0062	.MACHINE SCREW, #10-32 X 1/2	4
16	35.0117	.RELAY, 12V 35/20 AMP 280 MICRO	1
17	99.SF0405-1	.BOLT, SMF 1/4-20 X 5/8	7
18	99.SF04	.NUT, SRF 1/4-20 USS	6
19	11.0071	.CLAMP, CUSHIONED METAL 3/4"	1
20	60.1205	.SHIELD, ELECTRICAL HARNESS	1
21	60.1200	.COVER, FUSE PANEL WIRES	1
22	06.0057-1.25IN	.TRIM, EDGE GUARD 5/16" BLACK X 1-1/4"	1
23	06.0057-1.38IN	.TRIM, EDGE GUARD 5/16" BLACK X 1-3/8"	2

ELECTRICAL

ILLUSTRATED DRAWING Rear Fuse Panel

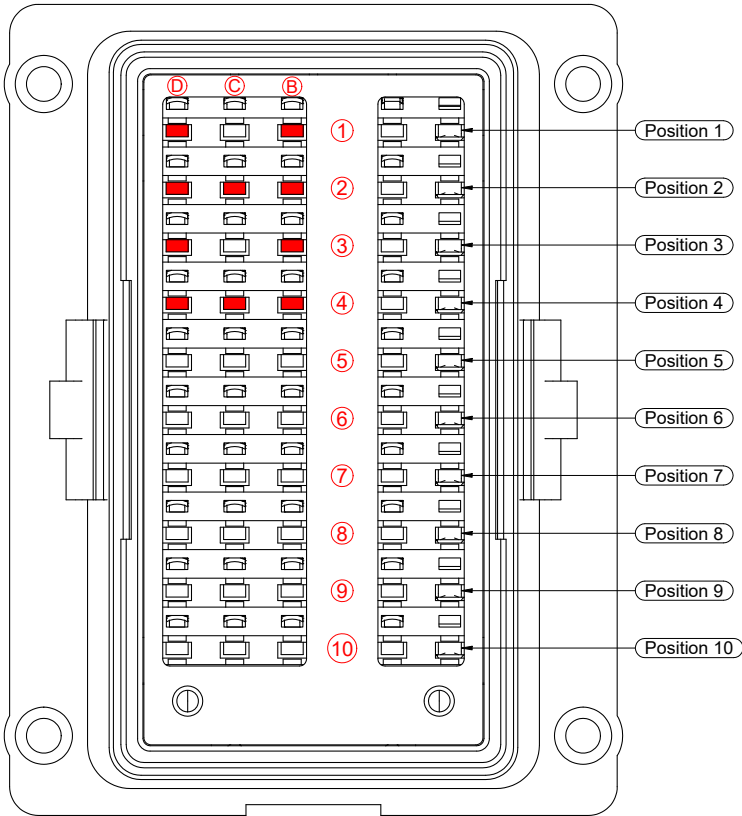

Ref. # / Position	Circuit
1*	Spreader
2*	Cab
3	Fuel Pump
4	Diesel Stop
5	Engine Run
6	Speedometer
7	Starter Relay
8*	Spreader Vibrator
9	Tractor Control Module 1
10	Tractor Control Module 2

*Optional Accessory

Reference 15 relays are installed in Position 1 - 2 and Position 3 - 4 as referenced by shaded ports. The relays must be oriented with the single center pin down.

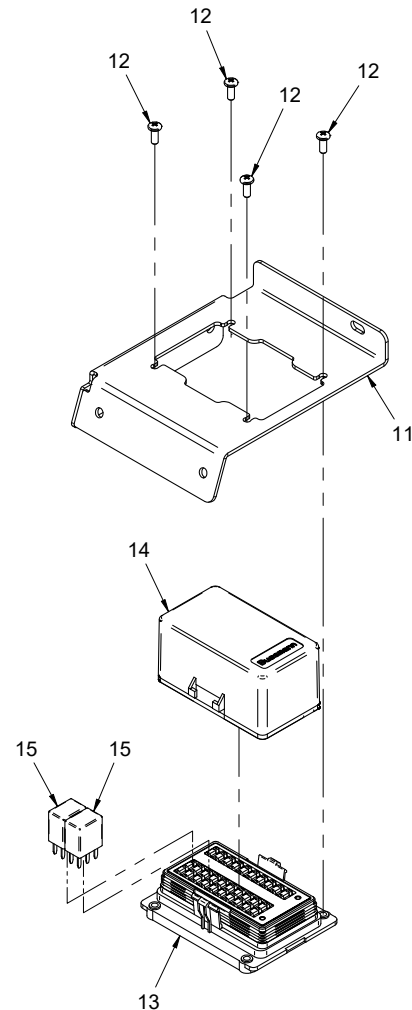

ELECTRICAL

Rear Fuse Panel

REF.	PART NO.	DESCRIPTION	QTY.
1	30.0429	.BREAKER, CIRCUIT 25 AMP MINI	1
2	30.0445	.BREAKER, CIRCUIT 30 AMP MINI	1
3	30.0333	.FUSE, 10 AMP MINI RED	1
4	30.0333	.FUSE, 10 AMP MINI RED	1
5	30.0332	.FUSE, 5 AMP MINI TAN	1
6	30.0332	.FUSE, 5 AMP MINI TAN	1
7	30.0335	.FUSE, 20 AMP MINI YELLOW	1
8	30.0333	.FUSE, 10 AMP MINI RED	1
9	30.0332	.FUSE, 5 AMP MINI TAN	1
10	30.0334	.FUSE, 15 AMP MINI BLUE	1
11	64.1758	.MOUNT, FUSE PANEL	1
12	99.K0062	.MACHINE SCREW, #10-32 X 1/2	4
13	30.0356	.FUSE PANEL, MINI NON-BUSSED	1
14	30.0331	.COVER, FUSE PANEL 30.0329	1
15	35.0117	.RELAY, 12V 35/20 AMP 280 MICRO	2

ELECTRICAL

ILLUSTRATED DRAWING Power Relay Module

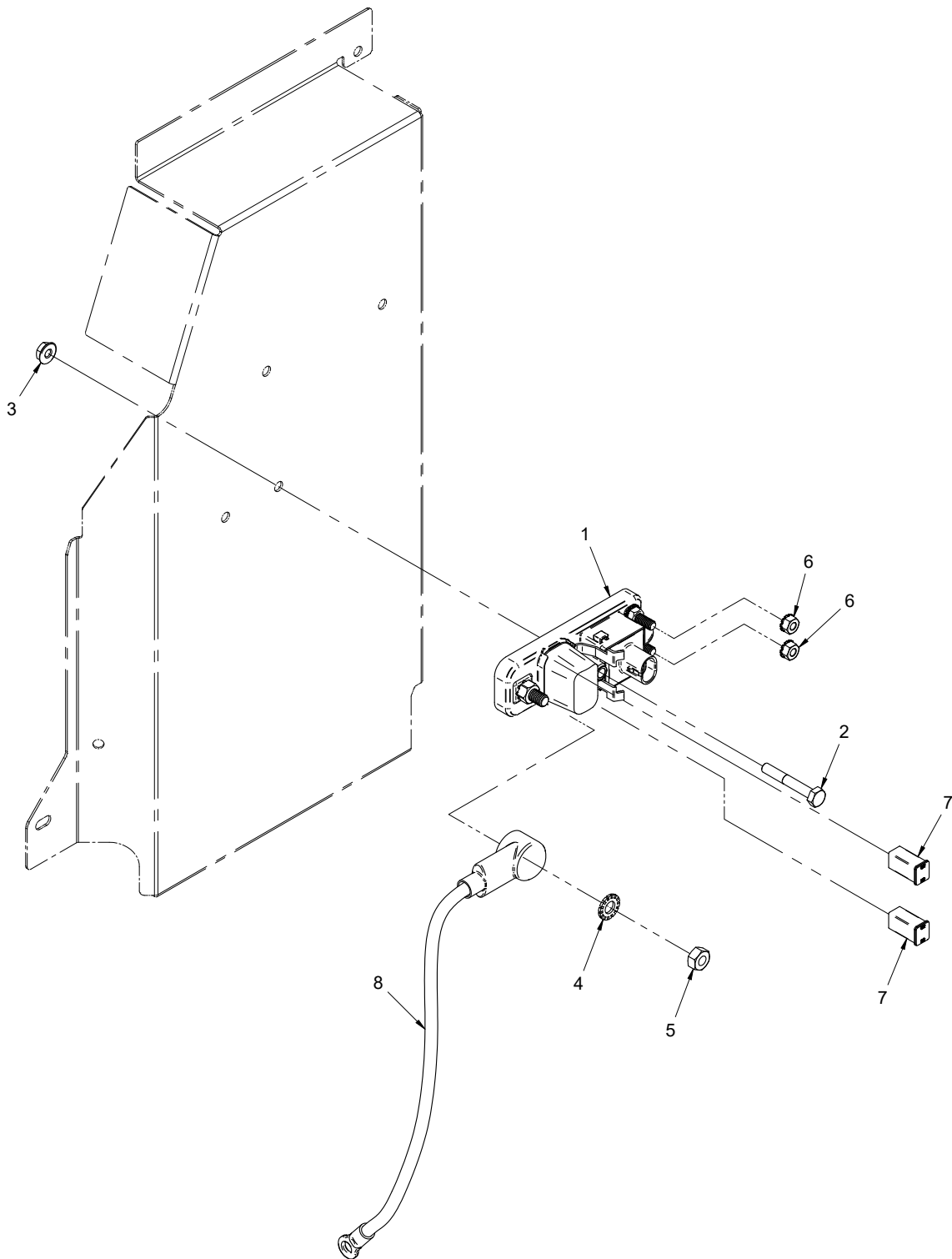

ELECTRICAL

Power Relay Module

REF.	PART NO.	DESCRIPTION	QTY.
1	30.0339	.MODULE, POWER RELAY	1
2	90.0414	.BOLT, 1/4-20 USS X 1-3/4"	1
3	99.SF04	.NUT, SF 1/4-20 USS	1
4	99.G0003	.WASHER, STAR-EXTERNAL 5/16	1
5	99.M0008	.NUT, M8 X 1.25MM ZP	1
6	99.M0029	.NUT, M6 X 1.0 W/LOCK WASHER	2
7	30.0374	.FUSE, 50A J-CASE ORANGE	2
8	32.0139	.CABLE, ASM POS 6 GA.	1

ELECTRICAL

ILLUSTRATED DRAWING RPM Sensor

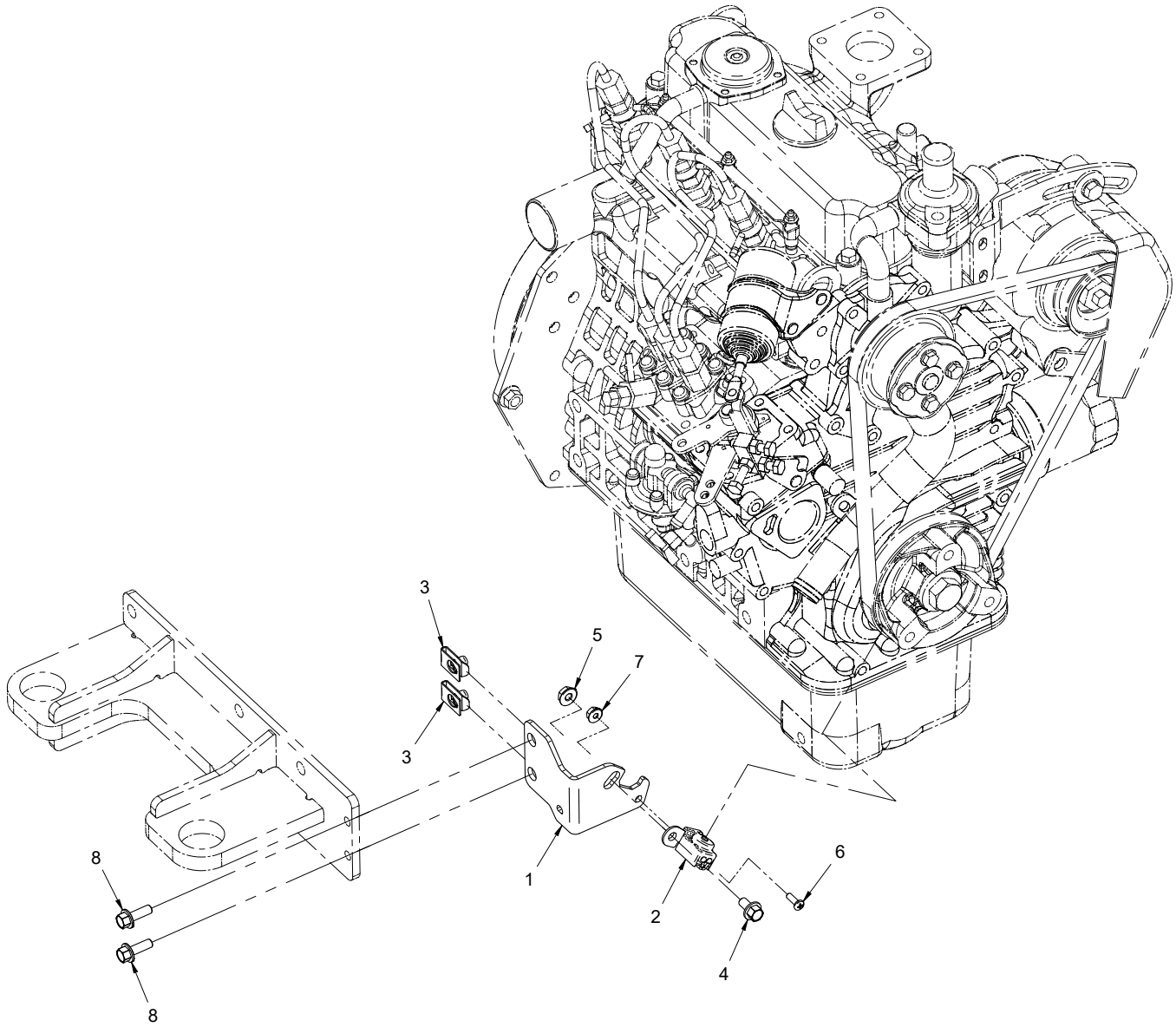

ELECTRICAL

RPM Sensor

REF.	PART NO.	DESCRIPTION	QTY.
1	64.1774	.MOUNT, RPM SENSOR	1
2	35.0139	.SENSOR, RPM	1
3	99.E0046	.NUT, "U" 1/4-20 EXTRUDED	2
4	99.SF0404-1	.BOLT, SMF 1/4-20 X 1/2	1
5	99.SF04	.NUT, SRF 1/4-20 USS	1
6	99.K0041	.MACHINE SCREW, #8-32 X 1/2	1
7	99.E0062	.NUT, SF #8-32	1
8	99.SF0406-1	.BOLT, SMF 1/4-20 X 3/4	2

ELECTRICAL

ILLUSTRATED DRAWING Speedometer Sensor

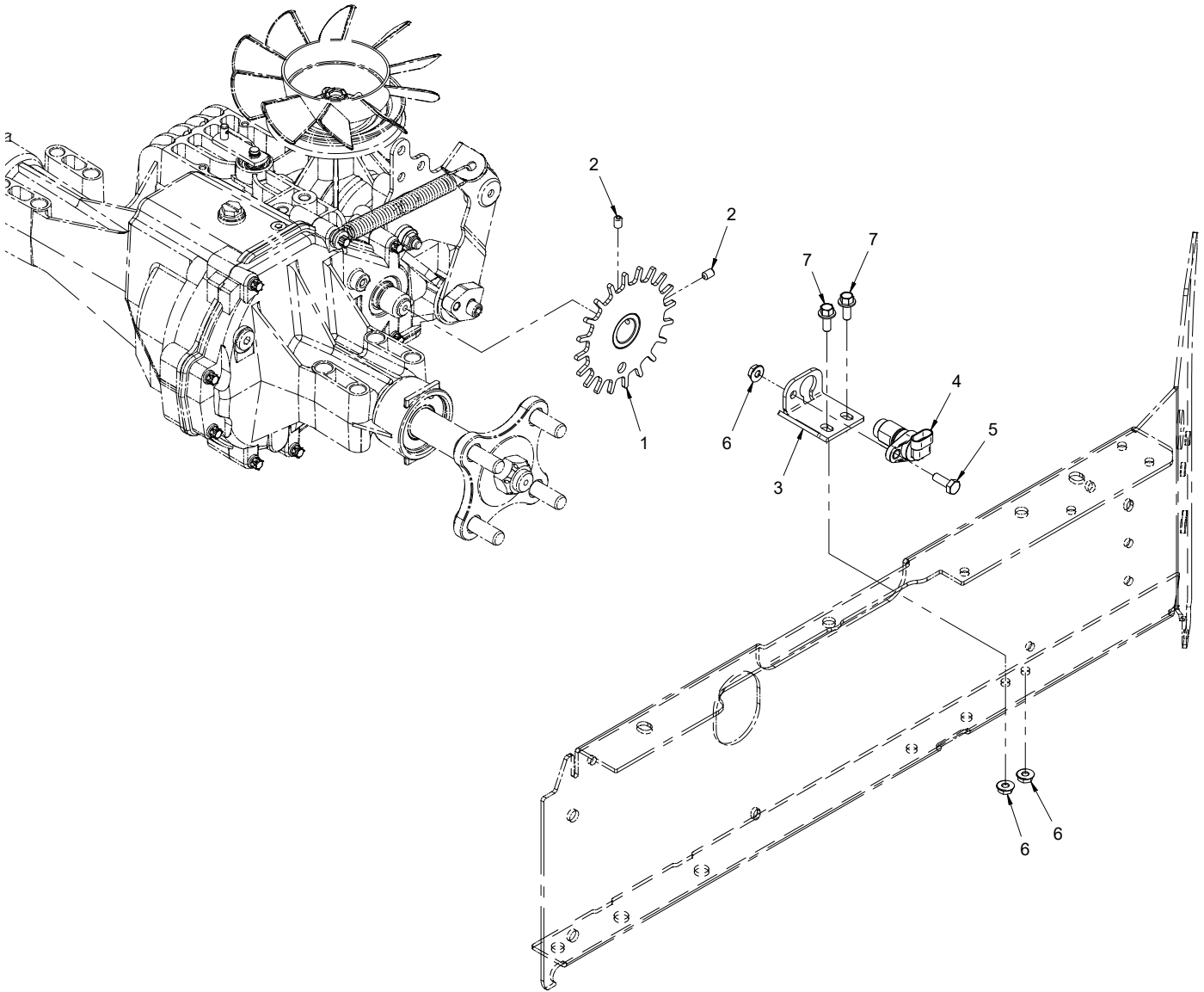

ELECTRICAL

Speedometer Sensor

REF.	PART NO.	DESCRIPTION	QTY.
1	64.1771	.PLATE, SPEED INDICATOR	1
2	85.SS11	.SET SCREW, 1/4-28 X 3/8"	2
3	64.1773	.MOUNT, SPEED SENSOR	1
4	35.0121	.SENSOR, GEAR TOOTH SPEED	1
5	90.0406	.BOLT, 1/4-20 USS X 3/4"	1
6	99.SF04	.NUT, SRF 1/4-20 USS	3
7	99.SF0405-1	.BOLT, SMF 1/4-20 X 5/8	2

HYDRAULICS

ILLUSTRATED DRAWING Hydraulic Diagram

Top View Shown Unless Noted

→ Charge Pressure →

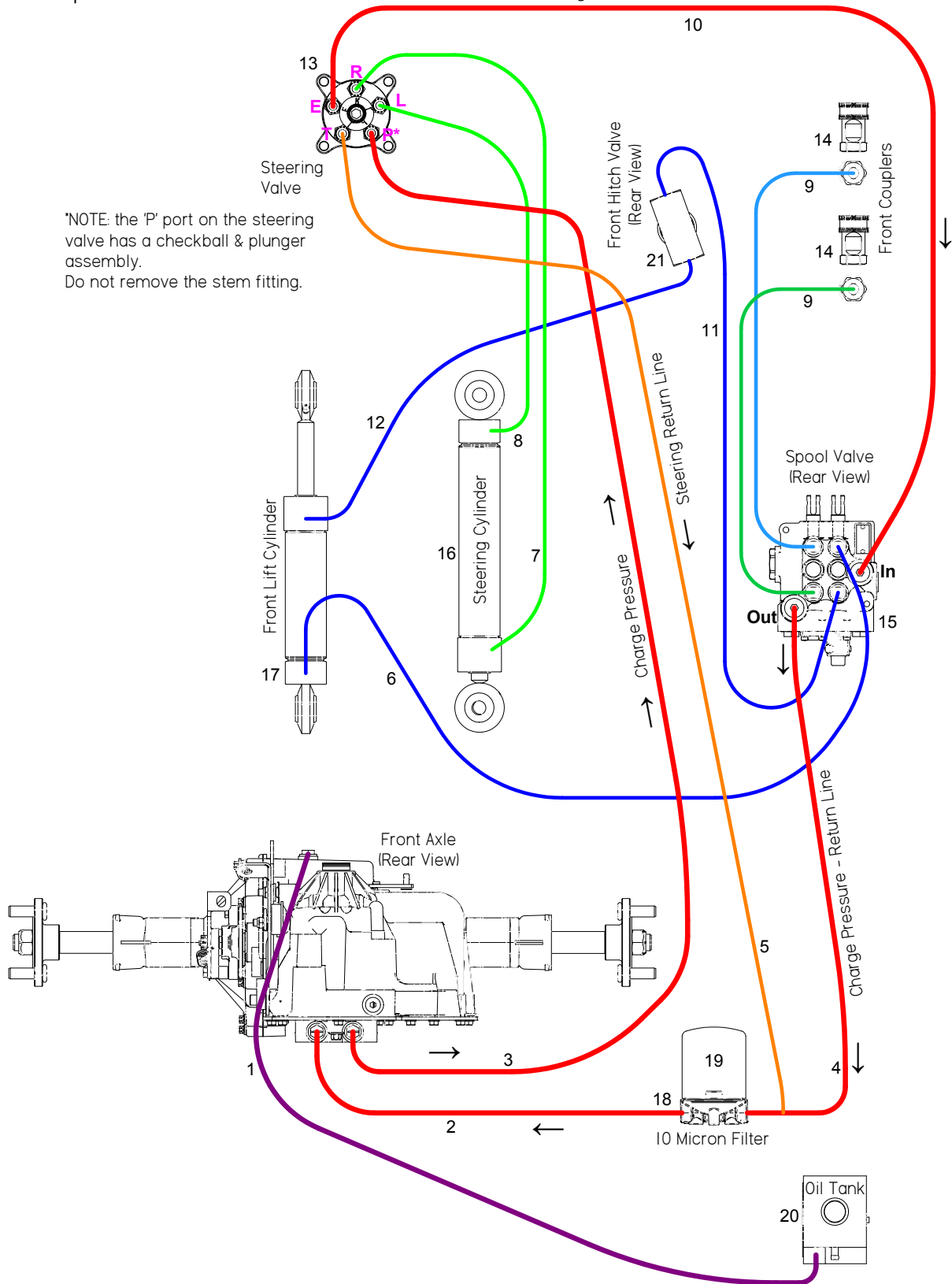

HYDRAULICS

Hydraulic Diagram

REF.	PART NO.	DESCRIPTION	QTY.
1	22.0066	.HOSE, 3/8X33.5 PLK 250PSI CPE	1
2	20.0314	.HOSE, 3/8X11.50 SAE 100R17 AR	1
3	20.0242	.HOSE, 3/8X61.00 SAE 100R17 AR	1
4	20.0312	.HOSE, 3/8X20.00 SAE 100R17 AR	1
5	20.0213	.HOSE, 1/4X46.00 SAE 100R17 AR	1
6	20.0248	.HOSE, 1/4X27.00 SAE 100R17 AR	1
7	20.0247	.HOSE, 1/4X41.00 SAE 100R17 AR	1
8	20.0246	.HOSE, 1/4X31.00 SAE 100R17 AR	1
9	20.0259	.HOSE, 1/4X20.00 SAE 100R17 AR	2
10	20.0243	.HOSE, 3/8X50.00 SAE 100R17 AR	1
11	20.0313	.HOSE, 1/4X21.00 SAE 100R17 AR	1
12	20.0282	.HOSE, 1/4X19.00 SAE 100R17 AR	1
13	23.0113	.VALVE, STEERING-DANFOSS 100CC.	1
14	23.0106	.COUPLER, QUICK FEMALE 1/4	2
15	23.0111-1	.VALVE, HY 2 SPL W/LH FLT,RH SP	1
16	23.0129	.CYLINDER, 1-1/2" X 8" STEERING	1
17	23.0130	.CYLINDER, 1-1/2" X 5"	1
18	21.0123	.FILTER, HEAD 06 ORB	1
19	21.0124	.FILTER, HYD. 10 MICRON CEL	1
20	47.0258	.TANK, COOLANT/HYDRAULIC OIL	1
21	23.0161	.VALVE, NEEDLE	1

HYDRAULICS

O-Ring Chart

Straight Thread O-Ring Boss - O-Ring Replacement Part Numbers						
SAE Fitting Size	Thread Size	VPI Part #	ID	OD	Width	AS568A Dash #
-04	7/16-20	26.0035	0.351"	0.495"	0.072"	904
-06	9/16-18	26.0036	0.468"	0.624"	0.078"	906
-08	3/4-16	26.0037	0.644"	0.818"	0.087"	908
-10	7/8-14	26.0038	0.755"	0.949"	0.097"	910
-12	1-1/16-12	26.0039	0.924"	1.156"	0.116"	912
-16	1-5/16-12	26.0043	1.171"	1.403"	0.116"	916

25.6400-(xx)-(xx) Fitting

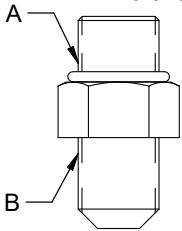

Fitting End A		O-Ring		Fitting End B		O-Ring	
SAE Fitting Size	Thread Size	AS568A Dash #	VPI Part #	SAE Fitting Size	Thread Size	AS568A Dash #	VPI Part #
-04	7/16-20	904	26.0035	-04	7/16-20	-	-
-06	9/16-18	906	26.0036	-06	9/16-18	-	-
-08	3/4-16	908	26.0037	-08	3/4-16	-	-
-10	7/8-14	910	26.0038	-10	7/8-14	-	-
-12	1-1/16-12	912	26.0039	-12	1-1/16-12	-	-
-16	1-5/16-12	916	26.0043	-16	1-5/16-12	-	-

25.6408-(xx) Plug

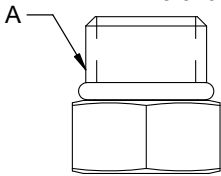

Fitting End A		O-Ring	
SAE Fitting Size	Thread Size	AS568A Dash #	VPI Part #
-04	7/16-20	904	26.0035
-06	9/16-18	906	26.0036
-08	3/4-16	908	26.0037
-10	7/8-14	910	26.0038
-12	1-1/16-12	912	26.0039
-16	1-5/16-12	916	26.0043

25.6801-(xx)-(xx) Fitting

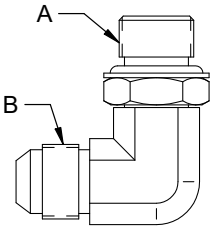

Fitting End A		O-Ring		Fitting End B		O-Ring	
SAE Fitting Size	Thread Size	AS568A Dash #	VPI Part #	SAE Fitting Size	Thread Size	AS568A Dash #	VPI Part #
-04	7/16-20	904	26.0035	-04	7/16-20	-	-
-06	9/16-18	906	26.0036	-06	9/16-18	-	-
-08	3/4-16	908	26.0037	-08	3/4-16	-	-
-10	7/8-14	910	26.0038	-10	7/8-14	-	-
-12	1-1/16-12	912	26.0039	-12	1-1/16-12	-	-
-16	1-5/16-12	916	26.0043	-16	1-5/16-12	-	-

25.6804-(x)-(x)-(x) Fitting

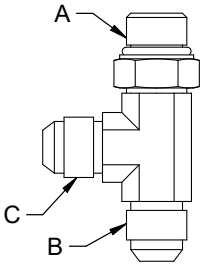

Fitting End A		O-Ring		Fitting End B & C		O-Ring	
SAE Fitting Size	Thread Size	AS568A Dash #	VPI Part #	SAE Fitting Size	Thread Size	AS568A Dash #	VPI Part #
-04	7/16-20	904	26.0035	-04	7/16-20	-	-
-06	9/16-18	906	26.0036	-06	9/16-18	-	-
-08	3/4-16	908	26.0037	-08	3/4-16	-	-
-10	7/8-14	910	26.0038	-10	7/8-14	-	-
-12	1-1/16-12	912	26.0039	-12	1-1/16-12	-	-
-16	1-5/16-12	916	26.0043	-16	1-5/16-12	-	-

HYDRAULICS

Blank Page

HYDRAULICS

ILLUSTRATED DRAWING Hydraulic Charge Pressure Circuit

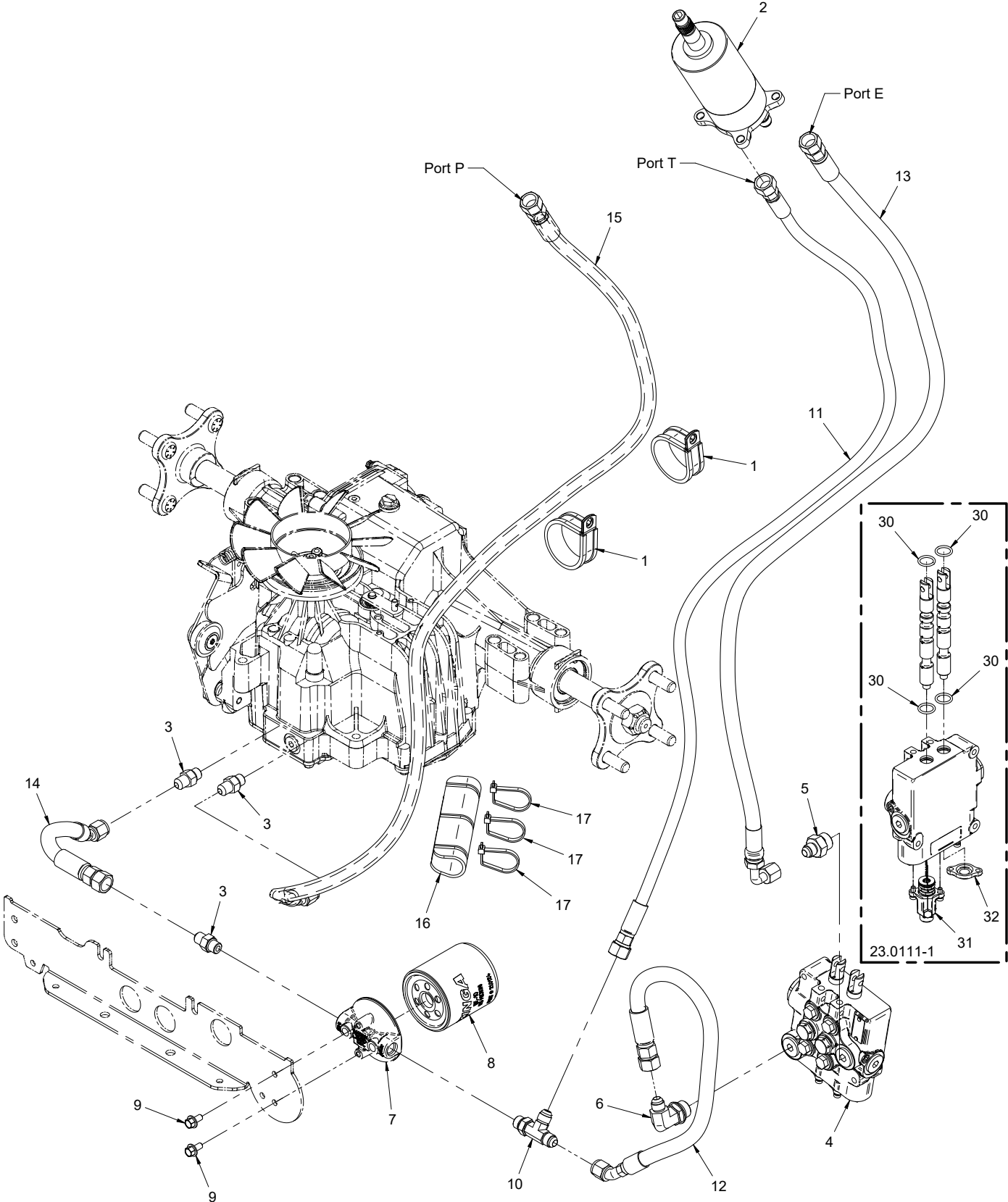

HYDRAULICS

Hydraulic Charge Pressure Circuit

REF.	PART NO.	DESCRIPTION	QTY.
1	11.0065	.CLAMP, CUSHIONED METAL 2"	2
2	23.0113	.VALVE, STEERING-DANFOSS 100CC.	1
	89.0095	.KIT, SEAL FOR 23.0113 STEER VALVE	1
3	25.6400-06-06	.FITTING, M CONN 3/8 X 3/8	3
4	23.0111-1	.VALVE, HY 2 SPL W/LH FLT, RH SP.	1
5	25.6400-06-08	.FITTING, M CONN 3/8 X 1/2	1
6	25.6801-06-08	.FITTING, 90 ME 3/8 X 1/2.	1
7	21.0123	.FILTER, HEAD 06 ORB	1
8	21.0124	.FILTER, HYD. 10 MICRON CEL.	1
9	99.SF0404-1	.BOLT, SMF 1/4-20 X 1/2	2
10	25.6804-6-6-6	.FITTING, M TEE 3/8X3/8X3/8	1
11	20.0213	.HOSE, 1/4 X 46.00 SAE 100R17AR.	1
12	20.0312	.HOSE, 3/8 X 20.00 SAE 100R17AR.	1
13	20.0243	.HOSE, 3/8 X 50.00 SAE 100R17 AR	1
14	20.0314	.HOSE, 3/8 X 11.50 SAE 100R17 AR	1
15	20.0242	.HOSE, 3/8 X 61.00 SAE 100R17 AR	1
16	44.0224	.SLEEVE, HOSE PROTECTOR 6"	1
17	30.0204	.TYTON TIE, #50 .190 X 12"	3
30	26.0027	.O-RING, 5/8ID X 13/16OD X 3/32	4
31	23.0111-7	.KIT, SPOOL FLOAT HYD. VALVE	1
32	23.0111-8	.CAP, VALVE.	1

HYDRAULICS

ILLUSTRATED DRAWING Hydraulic Oil Tank

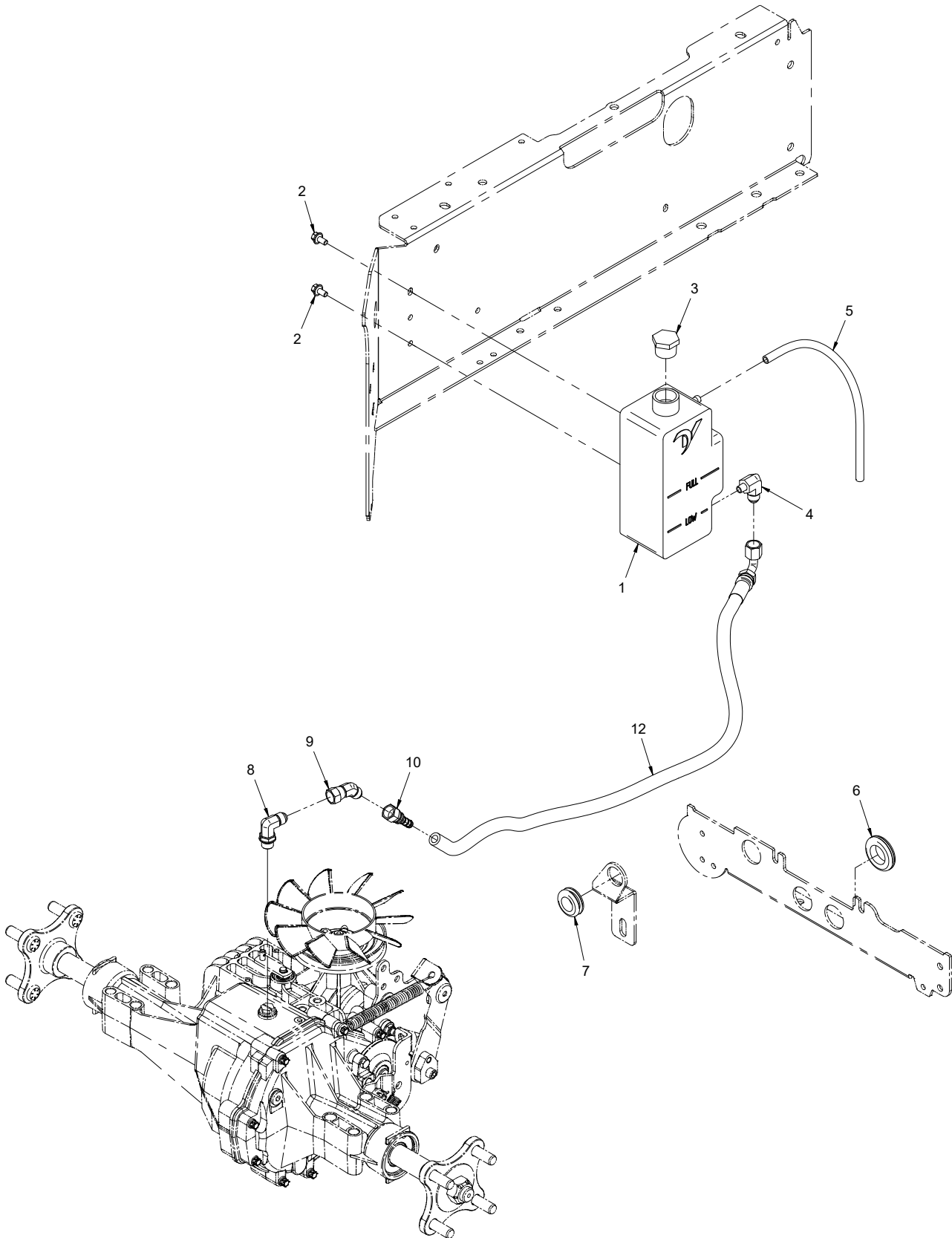

HYDRAULICS

Hydraulic Oil Tank

REF.	PART NO.	DESCRIPTION	QTY.
1	47.0258	.TANK, COOLANT / HYDRAULIC OIL	1
2	99.SF0404-1	.BOLT, SMF 1/4-20 X 1/2	2
3	05.0108	.PLUG, 3/4" NPT M, WHITE	1
4	25.2501-06-02F	.FITTING, 90 ME 3/8 X 1/8	1
5	27.T06-2-14IN	.TUBE, PVC CLEAR 3/8 OD X 1/4 ID X 14"	1
6	05.0044	.GROMMET, 1 ID, 1-3/4OD, 3/8THK	1
7	05.0045	.GROMMET, 3/4ID, 1 3/8OD, 1/2THK	1
8	25.6801-06-06	.FITTING, 90 ME 3/8 X 3/8	1
9	25.6502-06-06	.FITTING, 45 MFE 3/8 X 3/8	1
10	27.P06FS06	.HOSE END, #6 F JIC 3/8 P.LOCK	1
11	29.GF0003	.GREASE FTG, 1/4 SAE 45	1
12	22.0066	.HOSE, 3/8X35.5 PLK 250 PSI CPE	1

HYDRAULICS

ILLUSTRATED DRAWING Hydraulic Steering System

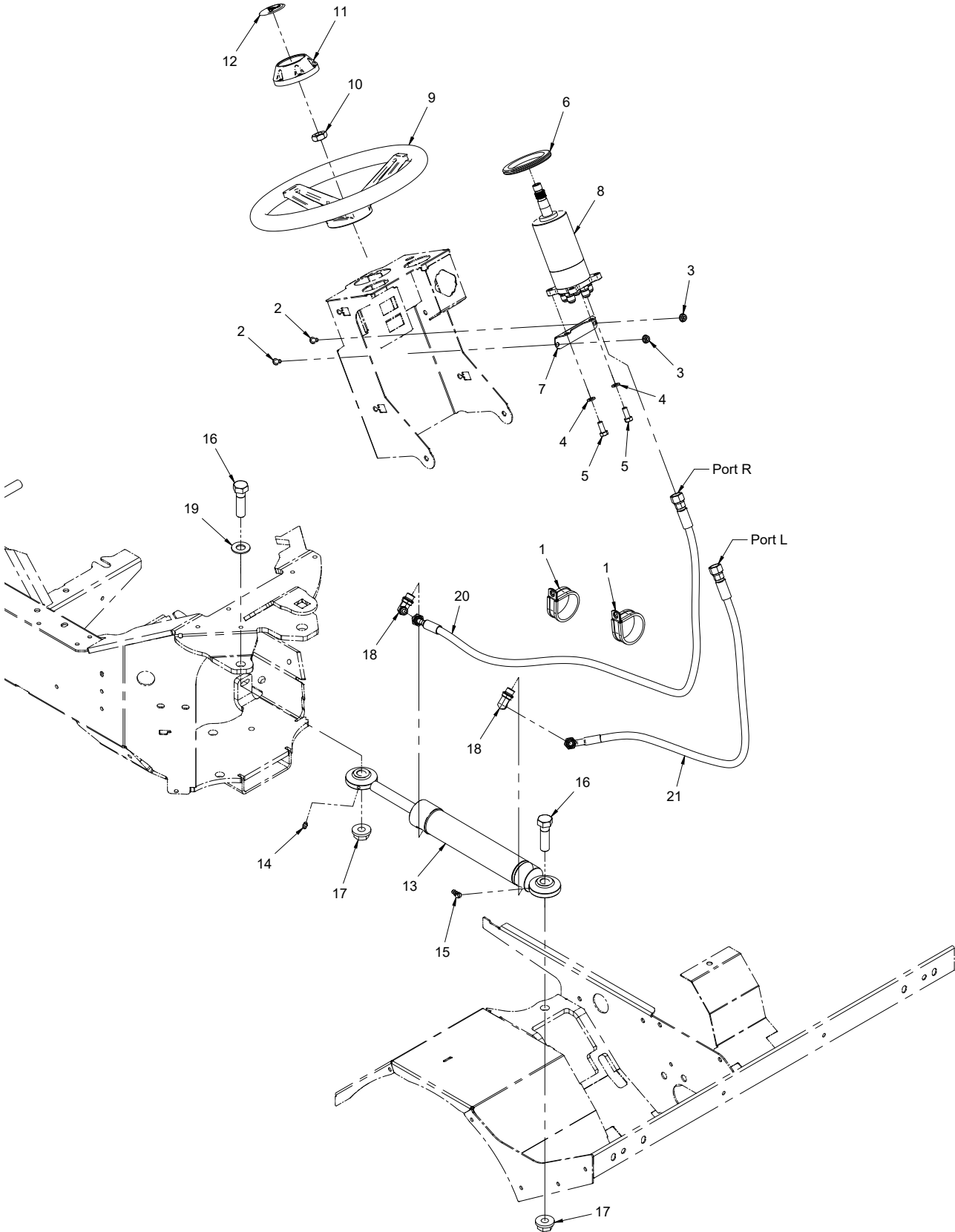

HYDRAULICS

Hydraulic Steering System

REF.	PART NO.	DESCRIPTION	QTY.
1	11.0065	.CLAMP, CUSHIONED METAL 2"	2
2	99.0404	.BOLT, 1/4-20 X 1/2 BSCS	2
3	99.SF04	.NUT, SRF 1/4-20 USS	2
4	96.05	.WASHER, LOCK 5/16	2
5	99.M0005	.BOLT, M8 X 1.25 P X 20MM LONG	2
6	05.0080	.GROMMET, 2-3/4 ID, 3-5/8 OD, 5/16T	1
7	64.1262	.BRACKET, STEERING VALVE MOUNT	1
8	23.0113	.VALVE, STEERING-DANFOSS 100CC	1
	89.0095	.KIT, SEAL FOR 23.0113 STEER VALVE	1
9	47.0117	.STEERING WHEEL, 16MM X 40T	1
10	99.E0011	.NUT, JAM 5/8 SAE	1
11	47.0118	.CAP, STEERING WHEEL	1
12	00.0207	.DECAL, VENTRAC DOME	1
13	23.0129	.CYLINDER, 1-1/2" X 8" STEERING	1
14	29.GF0001	.GREASE FTG, 1/4 SAE ST	1
15	29.GF0003	.GREASE FTG, 1/4 SAE 45	1
16	90.1018	.BOLT, 5/8-11 USS X 2-1/4	2
17	99.E0094	.LOCKNUT, 5/8-11 FLANGED STOVER	2
18	25.6801-06-06	.FITTING, 90 ME 3/8 X 3/8	2
19	95.10	.WASHER, FLAT 5/8 SAE	1
20	20.0247	.HOSE, 1/4 X 41.00 SAE 100R17 AR	1
21	20.0246	.HOSE, 1/4 X 31.00 SAE 100R17 AR	1

HYDRAULICS

ILLUSTRATED DRAWING Front Hitch Hydraulic Lift

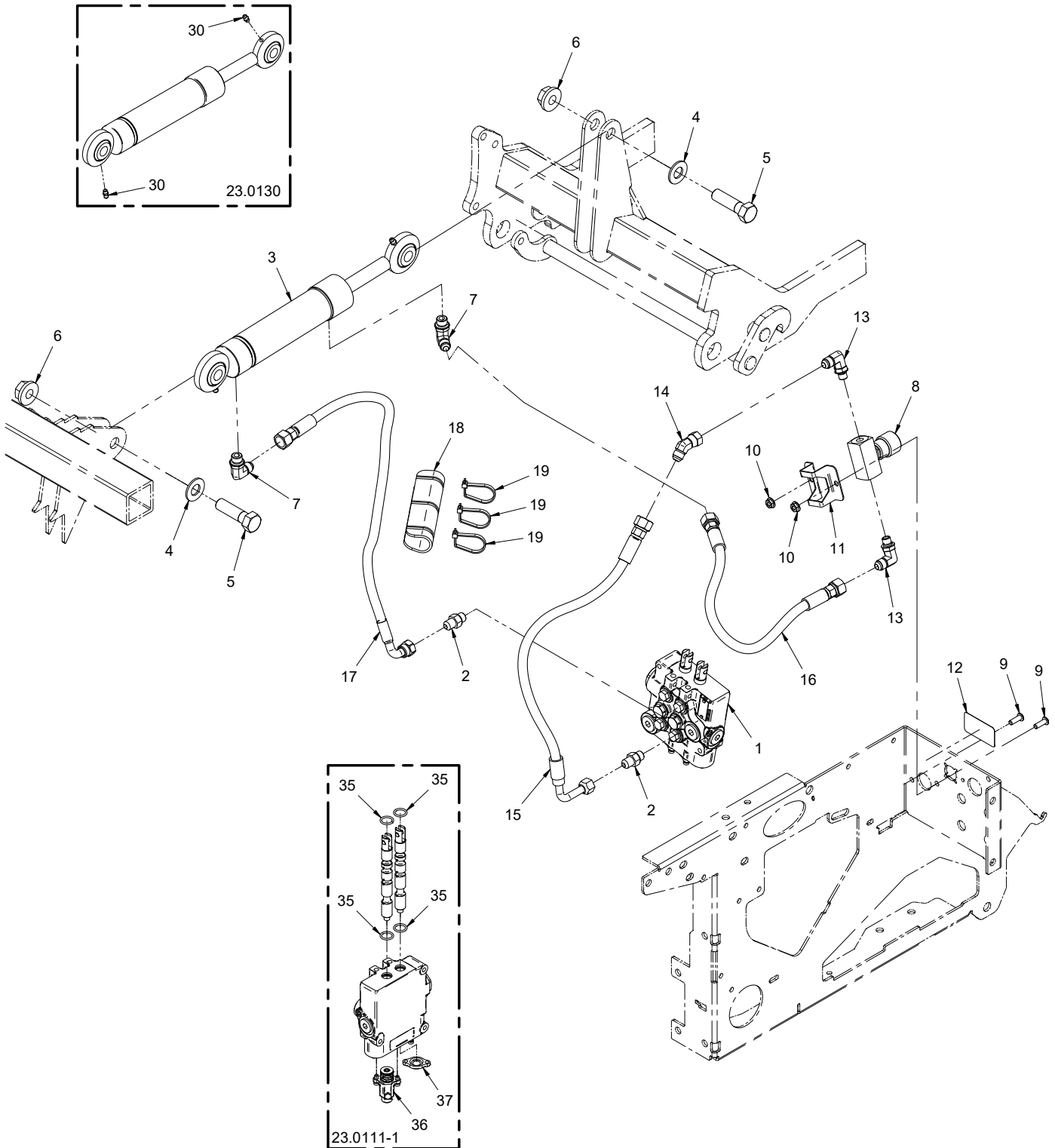

HYDRAULICS

Front Hitch Hydraulic Lift

REF.	PART NO.	DESCRIPTION	QTY.
1	23.0111-1	.VALVE, HY 2 SPL W/LH FLT, RH SP.	1
2	25.6400-06-06	.FITTING, M CONN 3/8 X 3/8	2
3	23.0130	.CYLINDER, 1-1/2" X 5"	1
4	95.10	.WASHER, FLAT 5/8 SAE	2
5	90.1018	.BOLT, 5/8-11 USS X 2-1/4	2
6	99.E0094	.LOCKNUT, 5/8-11 FLANGED STOVER.	2
7	25.6801-06-06	.FITTING, 90 ME 3/8 X 3/8.	2
8	23.0161	.VALVE, NEEDLE.	1
9	99.0406	.BOLT, 1/4-20 X 3/4 BSCS	2
10	99.SF04	.NUT, SRF 1/4-20 USS.	2
11	64.1719	.BRACKET, NEEDLE VALVE	1
12	00.0329	.DECAL, FRONT HITCH VALVE.	1
13	25.6801-06-04	.FITTING, 90 ME 3/8 X 1/4.	2
14	25.6502-06-06	.FITTING, 45 MFE 3/8 X 3/8	1
15	20.0313	.HOSE, 1/4X21.00 SAE 100R17 AR	1
16	20.0282	.HOSE, 1/4X19.00 SAE 100R17AR	1
17	20.0248	.HOSE, 1/4X27.00 SAE 100R17AR.	1
18	44.0224	.SLEEVE, HOSE PROTECTOR 6"	1
19	30.0204	.TYTON TIE, #50 .190 X 12"	3
30	29.GF0001	.GREASE FTG, 1/4 SAE ST	2
35	26.0027	.O-RING, 5/8ID X 13/16OD X 3/32	4
36	23.0111-7	.KIT, SPOOL FLOAT HYD. VALVE	1
37	23.0111-8	.CAP, VALVE.	1

HYDRAULICS

ILLUSTRATED DRAWING Auxiliary Hydraulic Quick Couplers

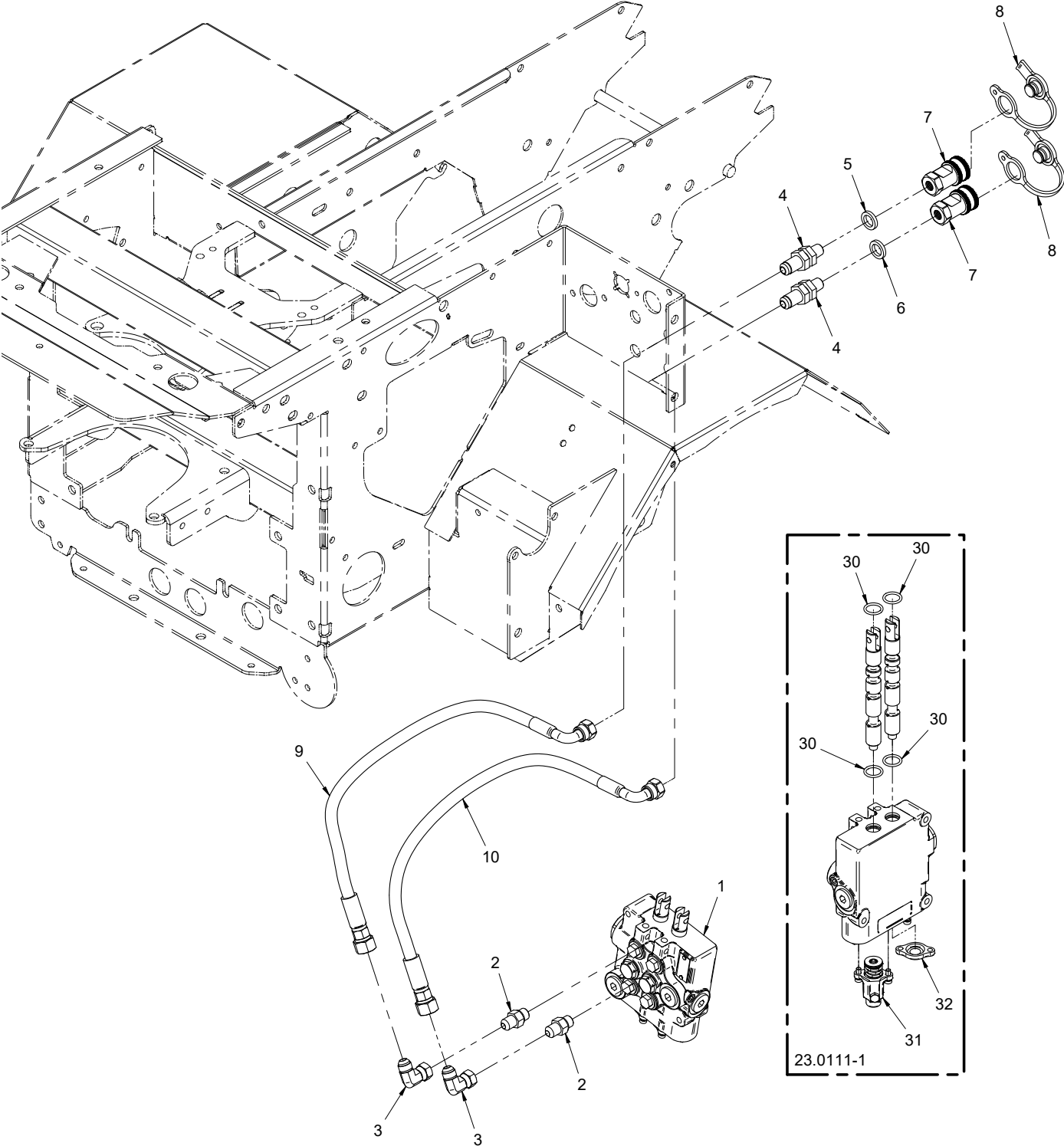

HYDRAULICS

Auxiliary Hydraulic Quick Couplers

REF.	PART NO.	DESCRIPTION	QTY.
1	23.0111-1	.VALVE, HY 2 SPL W/LH FLT, RH SP.	1
2	25.6400-06-06	.FITTING, M CONN 3/8 X 3/8	2
3	25.6500-06-06	.FITTING, 90 MFE 3/8 X 3/8	2
4	25.2706-04-06LN	.FITTING, BULKHEAD W/ LOCKNUT	2
5	05.0117	.WASHER, .544 ID X .817 X .14 YEL	1
6	05.0116	.WASHER, .544 ID X .817 X .14 RED	1
7	23.0106	.COUPLER, HYDRAULIC QUICK - 1/4 FEMALE	2
8	23.0126	.PLUG, DUST FOR 23.0106	2
9	20.0259	.HOSE, 1/4 X 20.00 SAE 100R17AR	1
10	20.0259	.HOSE, 1/4 X 20.00 SAE 100R17AR	1
30	26.0027	.O-RING, 5/8ID X 13/16OD X 3/32	4
31	23.0111-7	.KIT, SPOOL FLOAT HYD. VALVE	1
32	23.0111-8	.CAP, VALVE	1

ENGINE

ILLUSTRATED DRAWING Engine

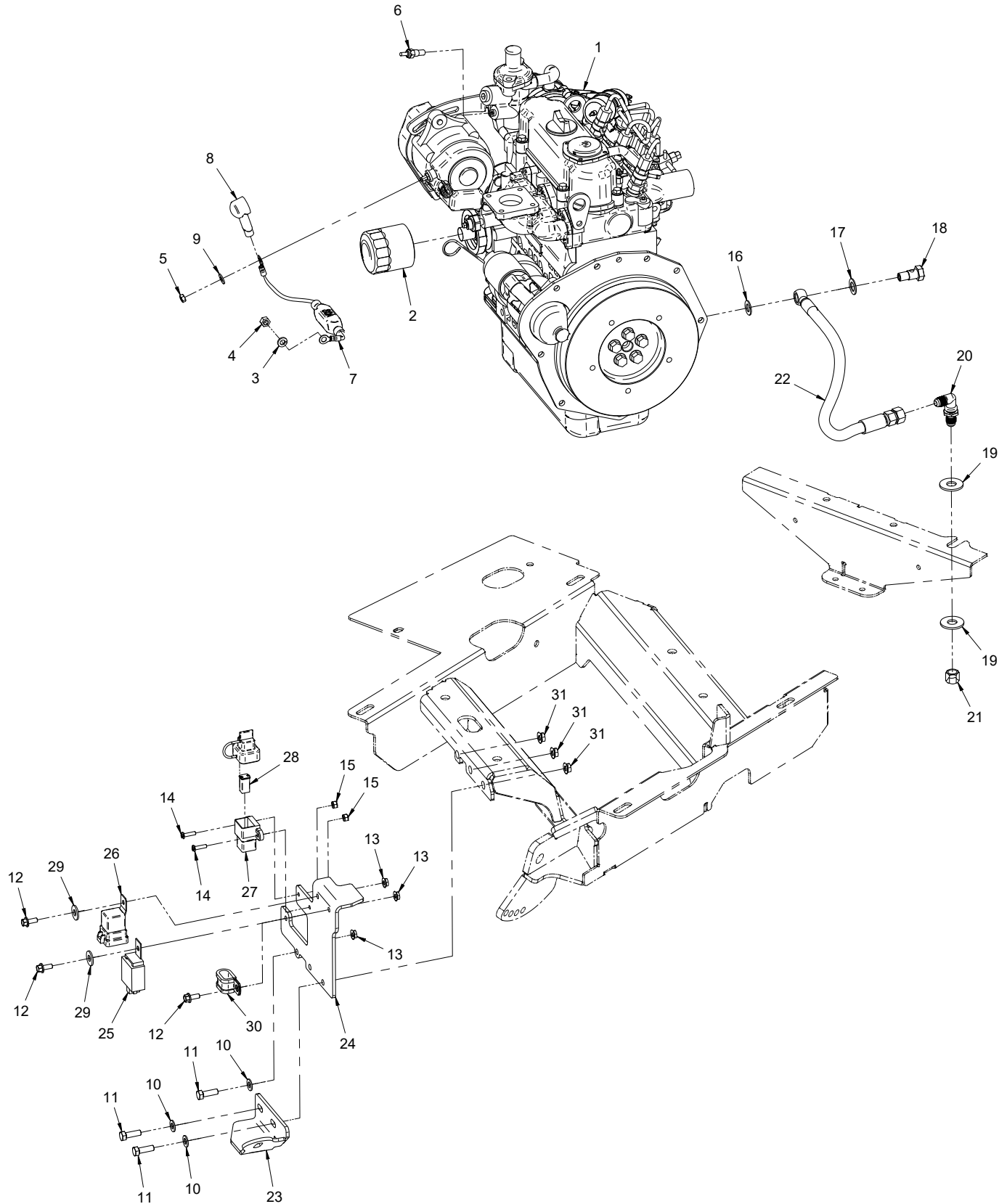

ENGINE

Engine

REF.	PART NO.	DESCRIPTION	QTY.
1	13.0297	.ENGINE, KUBOTA 25 HP DSL LC.	1
2	13.0267	.FILTER, ENGINE OIL KUBOTA.	1
3	13.04512-60080	.WASHER, SPRING LOCK.	1
4	13.02156-50080	.NUT, HEX	1
5	99.M0031	.NUT, M6 X 1.0MM	1
6	13.0286	.SENDING UNIT, TEMPERATURE.	1
7	30.0451	.FUSE, 80 AMP FUSE LINK	1
8	30.0321	.INSULATOR, ALTERNATOR POST	1
9	95.04	.WASHER, FLAT 1/4 SAE	1
10	95.05	.WASHER, FLAT 5/16 SAE	3
11	90.0508	.BOLT, 5/16-18 USS X 1"	3
12	99.SF0405-1	.BOLT, SMF 1/4-20 X 5/8	3
13	99.SF04	.NUT, SRF 1/4-20 USS.	3
14	99.K0047	.MACHINE SCREW, #10-32 X 3/4.	2
15	99.A1032N	.LOCKNUT, NYLON 10-32 STAINLESS.	2
16	99.B0108	.WASHER, SEALING 12MM COPPER.	1
17	99.B0106	.WASHER, SEALING 14MM COPPER.	1
18	14.0051	.BOLT, BANJO M12 X 1.25	1
19	94.08	.WASHER, FLAT 1/2 USS	2
20	25.2701-06-06LN	.FITTING, BULKHEAD 3/8 W/LN 90.	1
21	25.304-C-06	.FITTING, CAP 3/8 #6 JIC	1
22	22.0062	.HOSE, 3/8X13.50 PLK 250 PSI CPE.	1
23	64.1798	.MOUNT, GUIDE PULLEY.	1
24	64.1810	.BRACKET, FUSE & RELAY HOLDER.	1
25	13.T0070-31410	.TIMER, KEY STOP	1
26	35.0122	.RELAY, 12V 20/40A MINI SEALED	1
27	30.0402	.FUSE HOLDER, 50A J CASE	1
28	30.0374	.FUSE, 50A J-CASE ORANGE	1
29	94.05	.WASHER, FLAT 5/16 USS	2
30	11.0046	.CLAMP, CUSHIONED METAL 1/2"	1
31	99.SF05	.NUT, SRF 5/16-18 USS (Serial # 01001-01154).	3

ENGINE

ILLUSTRATED DRAWING Engine Mount

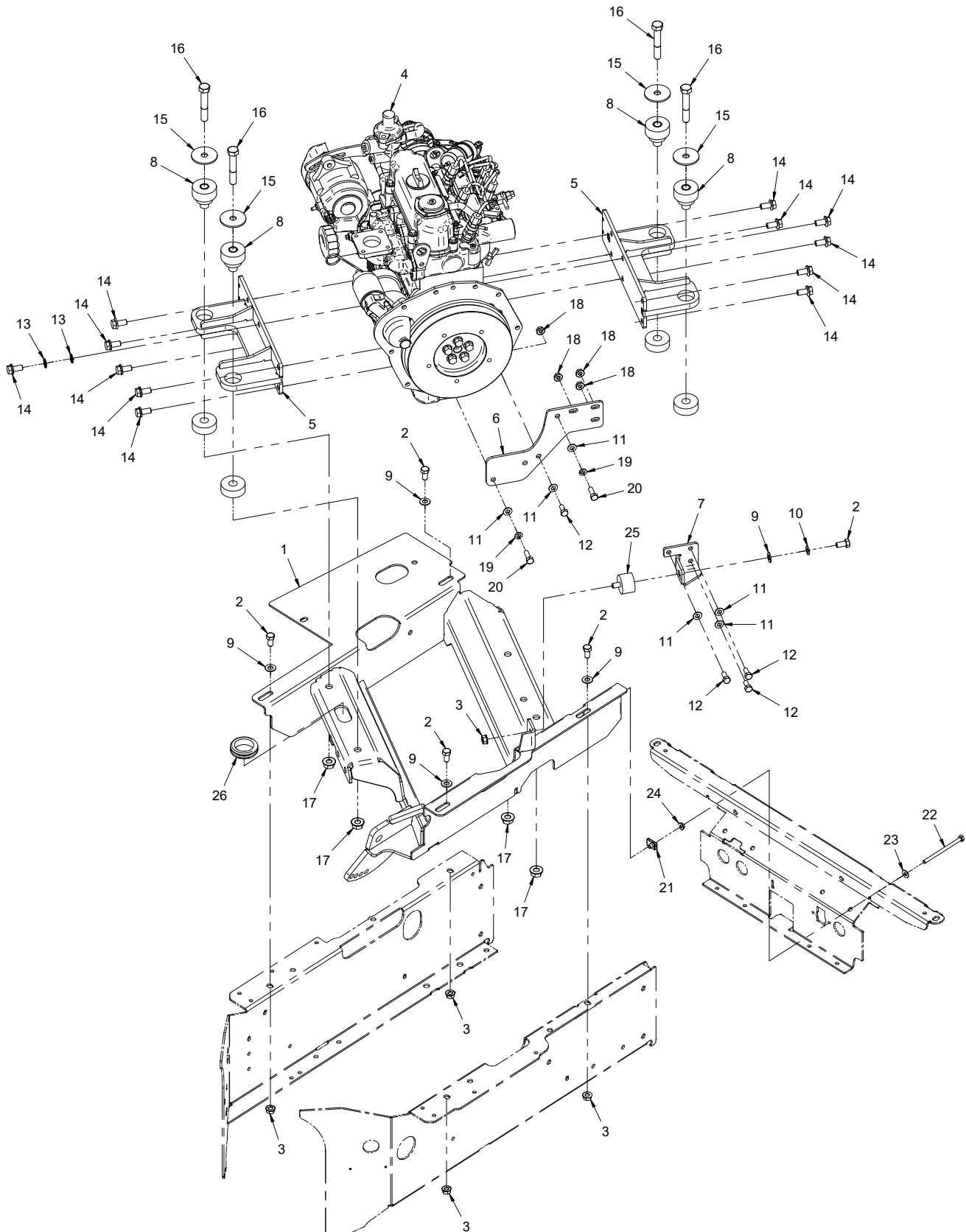

ENGINE

Engine Mount

REF.	PART NO.	DESCRIPTION	QTY.
1	62.1401	.FRAME, ENGINE D902	1
2	90.0606	.BOLT, 3/8-16 USS X 3/4	5
3	99.SF06	.NUT, SRF 3/8-16 USS	5
4	13.0297	.ENGINE, KUBOTA 25 HP DSL LC	1
5	64.1750	.MOUNT, ENGINE KUBOTA	2
6	64.1752	.MOUNT, ENGINE KUBOTA FLYWHEEL	1
7	64.1751	.MOUNT, ENGINE ISOLATOR	1
8	05.0149	.ISOLATOR, 1/2IDX1.88ODX2 PIECE	4
9	95.06	.WASHER, FLAT 3/8 SAE	5
10	96.06	.WASHER, LOCK 3/8	1
11	95.05	.WASHER, FLAT 5/16 SAE	6
12	90.0506	.BOLT, 5/16-18 USS X 3/4"	4
13	99.G0004	.WASHER, STAR-EXTERNAL 3/8	2
14	99.M0028	.BOLT, M10-1.25 X 20MM FLANGE	12
15	99.B0113	.WASHER, FENDER 1/2X 2X 1/8T	4
16	90.0824	.BOLT, 1/2-13 USS X 3	4
17	99.SF08	.NUT, SRF 1/2-13 USS	4
18	99.SF05	.NUT, SRF 5/16-18 USS	4
19	96.05	.WASHER, LOCK 5/16	2
20	99.M0009	.BOLT, M8 X 1.25 P X 25MM LONG	2
21	99.E0046	.NUT, "U" 1/4-20 EXTRUDED	1
22	90.0432-2	.BOLT, 1/4-20 USS X 4"	1
23	95.04	.WASHER, FLAT 1/4 SAE	1
24	99.SF04	.NUT, SRF 1/4-20 USS	1
25	05.0059	.ISOLATOR, 3/8-16 X 1.5 OD X 1	1
26	05.0036	.GROMMET, 1 1/2ID,2 1/8OD,9/16T	1

ENGINE

ILLUSTRATED DRAWING Throttle Control

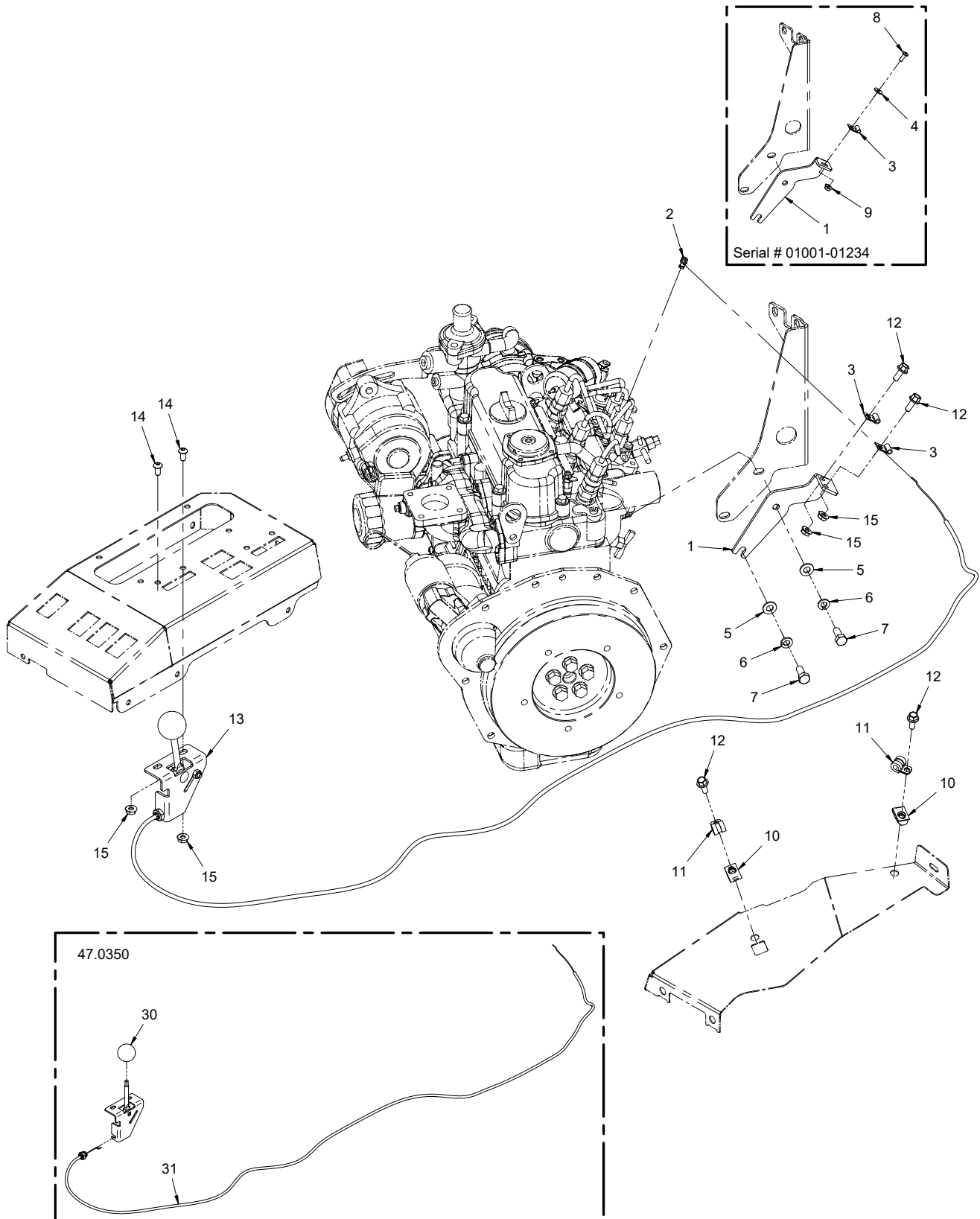

ENGINE

Throttle Control

REF.	PART NO.	DESCRIPTION	QTY.
1	64.1811	.BRACKET, THROTTLE CABLE (Serial # 01001-01234)	1
1	64.1857	.BRACKET, THROTTLE CABLE (Serial # 01235-)	1
2	47.0234	.THROTTLE CONTROL, WIRE SWIVEL	1
3	45.0052	.CLAMP, 3/16 CABLE CONDUIT (Serial # 01001-01234)	1
3	45.0053	.CLAMP, 3/16 VINYL COATED CABLE (Serial # 01235-)	2
4	99.B0051	.WASHER, FLAT #10 (Serial # 01001-01234)	1
5	95.05	.WASHER, FLAT 5/16 SAE	2
6	96.05	.WASHER, LOCK 5/16	2
7	99.M0005	.BOLT, M8 X 1.25 P X 20MM LONG	2
8	99.K0062	.MACHINE SCREW, #10-32 X 1/2 (Serial # 01001-01234)	1
9	99.E0035	.NUT, SRF #10-32 (Serial # 01001-01234)	1
10	99.E0046	.NUT, "U" 1/4-20 EXTRUDED	2
11	11.0058	.CLAMP, CUSHIONED 3/8" ROUND	2
12	99.SF0405-1	.BOLT, SMF 1/4-20 X 5/8 (Serial # 01001-01234)	2
12	99.SF0405-1	.BOLT, SMF 1/4-20 X 5/8 (Serial # 01235-)	4
13	47.0350	.CABLE, THROTTLE ASM 70"	1
14	99.0404	.BOLT, 1/4-20 X 1/2 BSCS	2
15	99.SF04	.NUT, SRF 1/4-20 USS (Serial # 01001-01234)	2
15	99.SF04	.NUT, SRF 1/4-20 USS (Serial # 01235-)	4
30	47.0363	.KNOB, THROTTLE BLACK	1
31	47.0350-1	.CABLE, PUSH/PULL 70"	1

ENGINE

ILLUSTRATED DRAWING Exhaust System

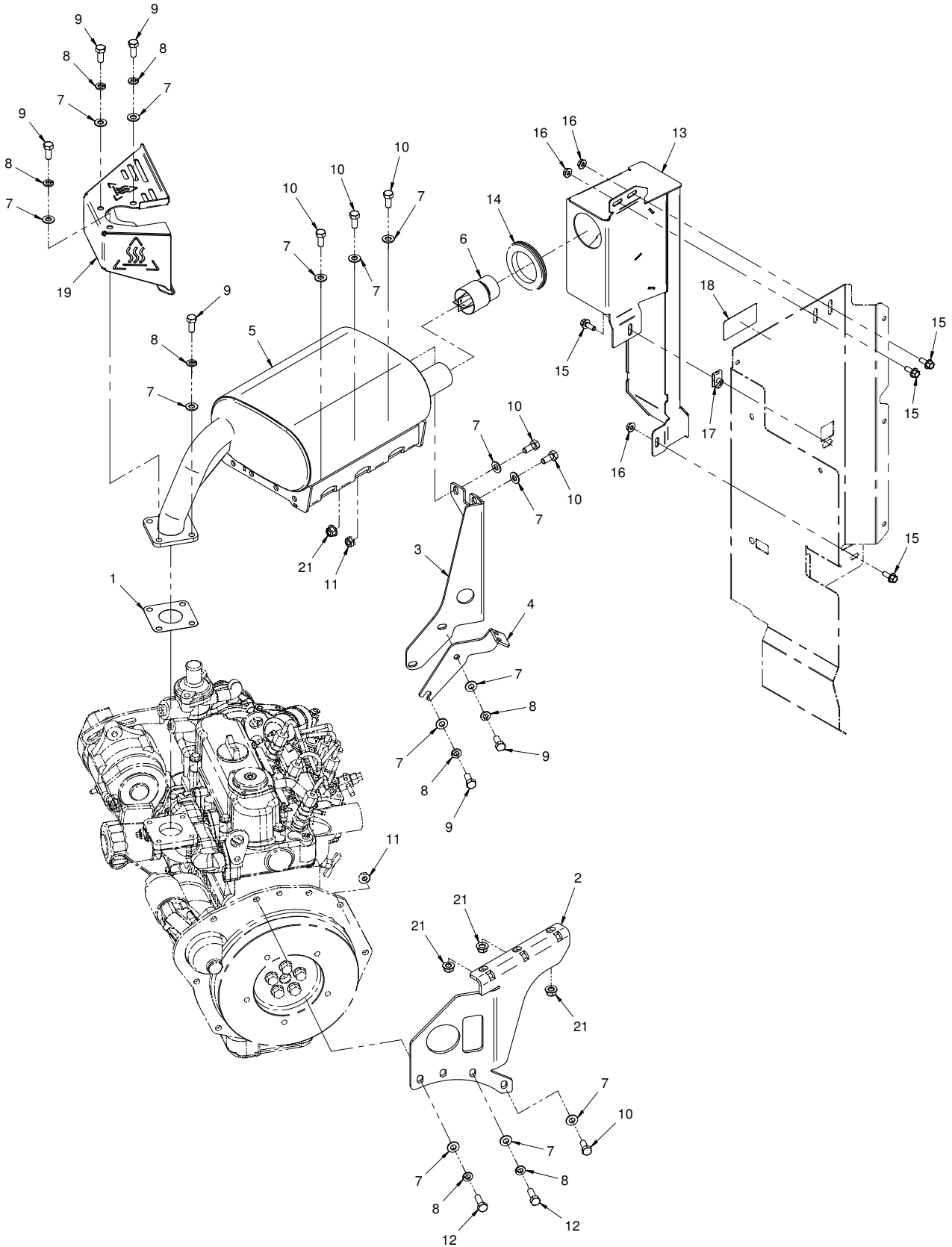

ENGINE

Exhaust System

REF.	PART NO.	DESCRIPTION	QTY.
1	13.0173	.GASKET, EXHAUST/MUFFLER	1
2	64.1813	.MOUNT, MUFFLER FLYWHEEL	1
3	64.1812	.MOUNT, MUFFLER INTAKE SIDE	1
4	64.1811	.BRACKET, THROTTLE CABLE (Serial # 01001-01234)	1
4	64.1857	.BRACKET, THROTTLE CABLE (Serial # 01235-)	1
5	13.0290	.MUFFLER, EX CONDITIONER	1
6	13.0307	.TUBE, SPARK ARRESTOR 1.5"	1
7	95.05	.WASHER, FLAT 5/16 SAE	14
8	96.05	.WASHER, LOCK 5/16	8
9	99.M0005	.BOLT, M8 X 1.25 P X 20MM LONG	6
10	90.0506	.BOLT, 5/16-18 USS X 3/4"	6
11	99.SF05	.NUT, SRF 5/16-18 USS	2
12	99.M0009	.BOLT, M8 X 1.25 P X 25MM LONG	2
13	13.0305	.BAFFLE, EXHAUST	1
14	05.0151	.GROMMET, 2" ID, 3" OD, 3/8"THK.	1
15	99.SF0405-1	.BOLT, SMF 1/4-20 X 5/8	4
16	99.SF04	.NUT, SRF 1/4-20 USS	3
17	99.E0046	.NUT, "U" 1/4-20 EXTRUDED	1
18	00.0374	.DECAL, HOT SURFACE	1
19	60.1219-1	.SHIELD, EX MANIFLD W/HEAT TAPE	1
21	99.E0102	.NUT, LOCKING FLANGE 5/16-18	4

ENGINE

ILLUSTRATED DRAWING Cooling System

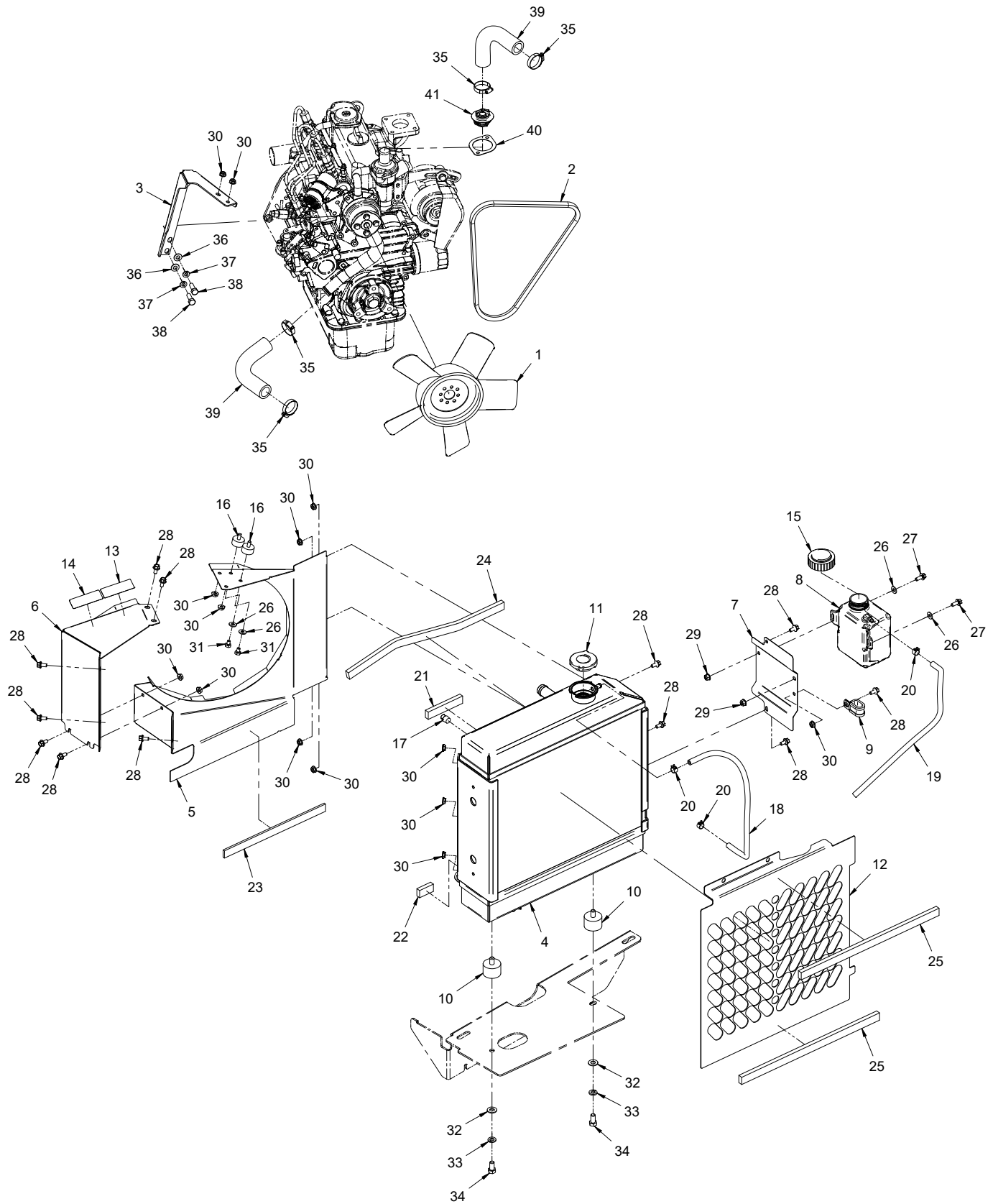

ENGINE

Cooling System

REF.	PART NO.	DESCRIPTION	QTY.
1	13.17454-74111	.FAN, COOLING 320MM SUCTION	1
2	13.17472-97010	.V BELT, FM35.0 IN	1
3	64.1764	.BRACE, RADIATOR	1
4	47.0342	.RADIATOR, LH KUBOTA	1
5	60.1202	.SHROUD, RADIATOR 47.0342 FRONT	1
6	60.1184	.SHROUD, RADIATOR 47.0342 REAR	1
7	64.1786	.MOUNT, COOLANT RECOVERY TANK	1
8	47.0317	.TANK, COOLANT RECOVER	1
9	11.0046	.CLAMP, CUSHIONED METAL 1/2"	1
10	05.0059	.ISOLATOR, 3/8-16 X 1.5 OD X 1	2
11	47.0334	.CAP, RADIATOR 14#	1
12	64.1794	.SCREEN, RADIATOR FOR 47.0342	1
13	00.0341	.DECAL, WARNING FAN	1
14	00.0374	.DECAL, HOT SURFACE	1
15	47.0319	.CAP, COOLANT RECOVERY TANK	1
16	05.0135	.ISOLATOR, 1/4-20 X 1/2 X 1" F/M	2
17	29.P04	.PIPE, PLUG 1/4" NPT SQUARE HEAD	1
18	27.A04-18IN	.HOSE, NEOP BLACK 1/4 X 7/16 X 18"	1
19	27.A04-20IN	.HOSE, NEOP BLACK 1/4 X 7/16 X 20"	1
20	11.0049	.CLAMP, HOSE BAND 1/2" OD HOSE	3
21	06.0055-3.75IN	.WEATHERSTRIP, 3/8 X 3/4 X 3-3/4"	1
22	06.0055-1.5IN	.WEATHERSTRIP, 3/8 X 3/4 X 1-1/2"	1
23	06.0047-11IN	.WEATHERSTRIP, 3/16 X 3/4 X 11"	1
24	06.0055-17.5IN	.WEATHERSTRIP, 3/8 X 3/4 X 17-1/2"	1
25	06.0055-15IN	.WEATHERSTRIP, 3/8 X 3/4 X 15"	2
26	95.04	.WASHER, FLAT 1/4 SAE	4
27	99.SF0405-1	.BOLT, SMF 1/4-20 X 5/8	2
28	99.SF0404-1	.BOLT, SMF 1/4-20 X 1/2	12
29	99.E0101	.NUT, LOCKING FLANGE 1/4-20	2
30	99.SF04	.NUT, SRF 1/4-20 USS	14
31	90.0403	.BOLT, 1/4-20 USS X 3/8	2
32	95.06	.WASHER, FLAT 3/8 SAE	2
33	96.06	.WASHER, LOCK 3/8	2
34	90.0606	.BOLT, 3/8-16 USS X 3/4	2
35	11.0052	.CLAMP, HOSE SS 13/16 X 1-1/2	4
36	95.05	.WASHER, FLAT 5/16 SAE	2
37	96.05	.WASHER, LOCK 5/16	2
38	99.M0009	.BOLT, M8 X 1.25 P X 25MM LONG	2
39	13.0262	.HOSE, RADIATOR UPPER KUBOTA	2
40	13.16221-73270	.GASKET, THERMOSTAT	1
41	13.19434-73014	.THERMOSTAT, 160A° KUBOTA (Serial # 1001-1366)	1
41	13.15321-73016	.THERMOSTAT, 180A° KUBOTA (Serial # 1367-)	1

ENGINE

ILLUSTRATED DRAWING Air Intake

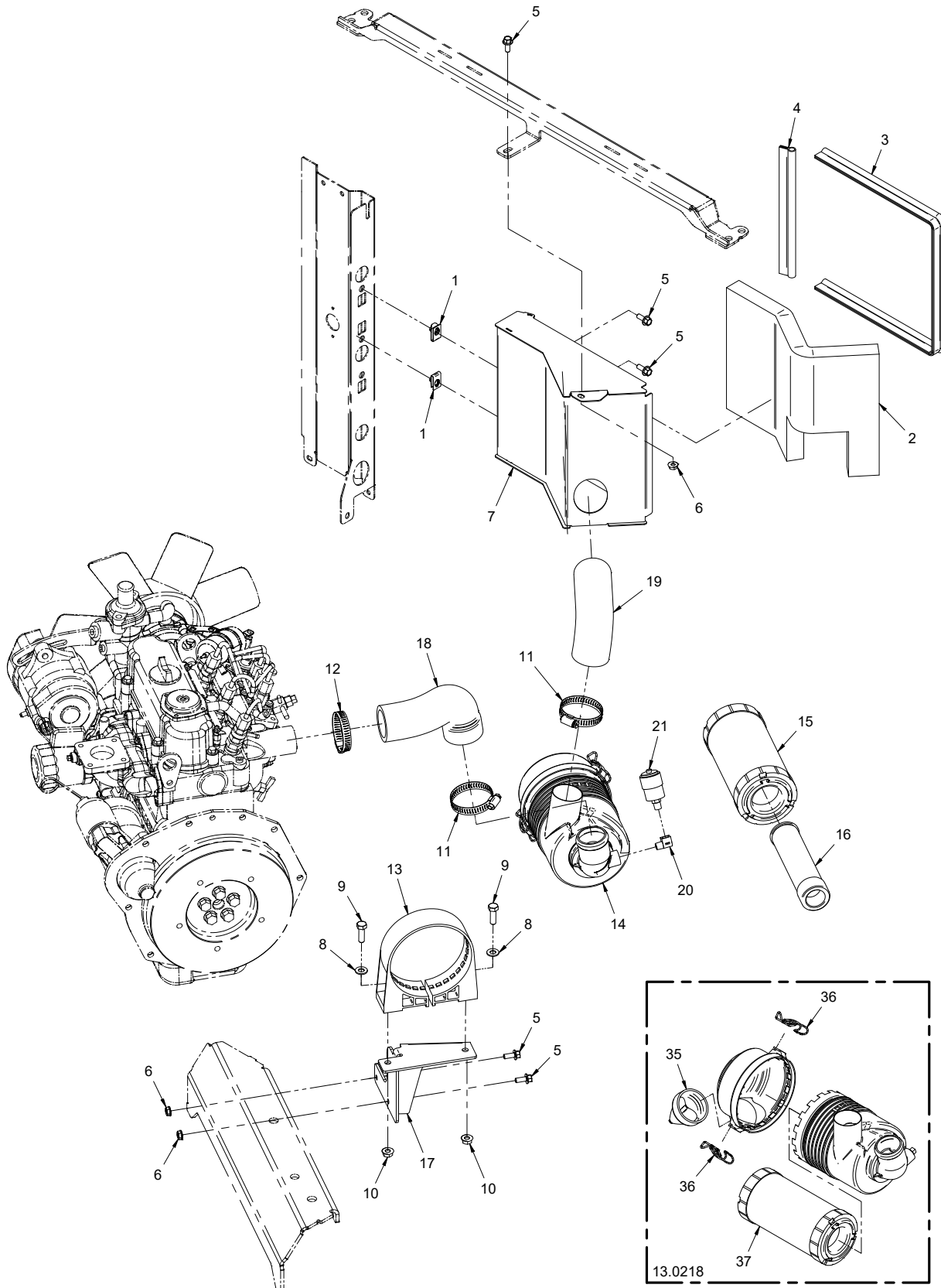

ENGINE

Air Intake

REF.	PART NO.	DESCRIPTION	QTY.
1	99.E0046	.NUT, "U" 1/4-20 EXTRUDED	2
2	44.0342	.INSULATION, AIR INTAKE BOX	1
3	06.0043-28IN	.TRIM, TRIM SEAL W/BULB X 28"	1
4	06.0043-8IN	.TRIM, TRIM SEAL W/BULB X 8"	1
5	99.SF0405-1	.BOLT, SMF 1/4-20 X 5/8	5
6	99.SF04	.NUT, SRF 1/4-20 USS	3
7	60.1196	.BAFFLE, AIR INTAKE	1
8	95.05	.WASHER, FLAT 5/16 SAE	2
9	90.0508	.BOLT, 5/16-18 USS X 1"	2
10	99.SF05	.NUT, SRF 5/16-18 USS	2
11	11.0044	.CLAMP, HOSE S/S 1-9/16- 2-1/2	2
12	11.0043	.CLAMP, HOSE S/S 1-5/16 - 2-1/4	1
13	13.0219	.CLAMP, AIR FILTER	1
14	13.0218	.AIR CLEANER, COMPETE ASM	1
15	13.0226	.FILTER, AIR OUTER ELEMENT	1
16	13.0227	.FILTER, AIR - INNER ELEMENT	1
17	64.1755	.MOUNT, AIR CLEANER	1
18	13.0293	.HOSE, INTAKE 3400Y	1
19	13.0294	.HOSE, AIR CLEANER INLET 3400Y	1
20	29.S9002B	.PIPE, STREET 90 EL. 1/8 BRASS	1
21	35.0143	.INDICATOR, RESTRICTION 15" H2O	1
35	13.522958	.VALVE, DRAIN	1
36	13.538928	.LATCH	2
37	13.0226	.FILTER, AIR OUTER ELEMENT	1

ENGINE

ILLUSTRATED DRAWING Fuel System

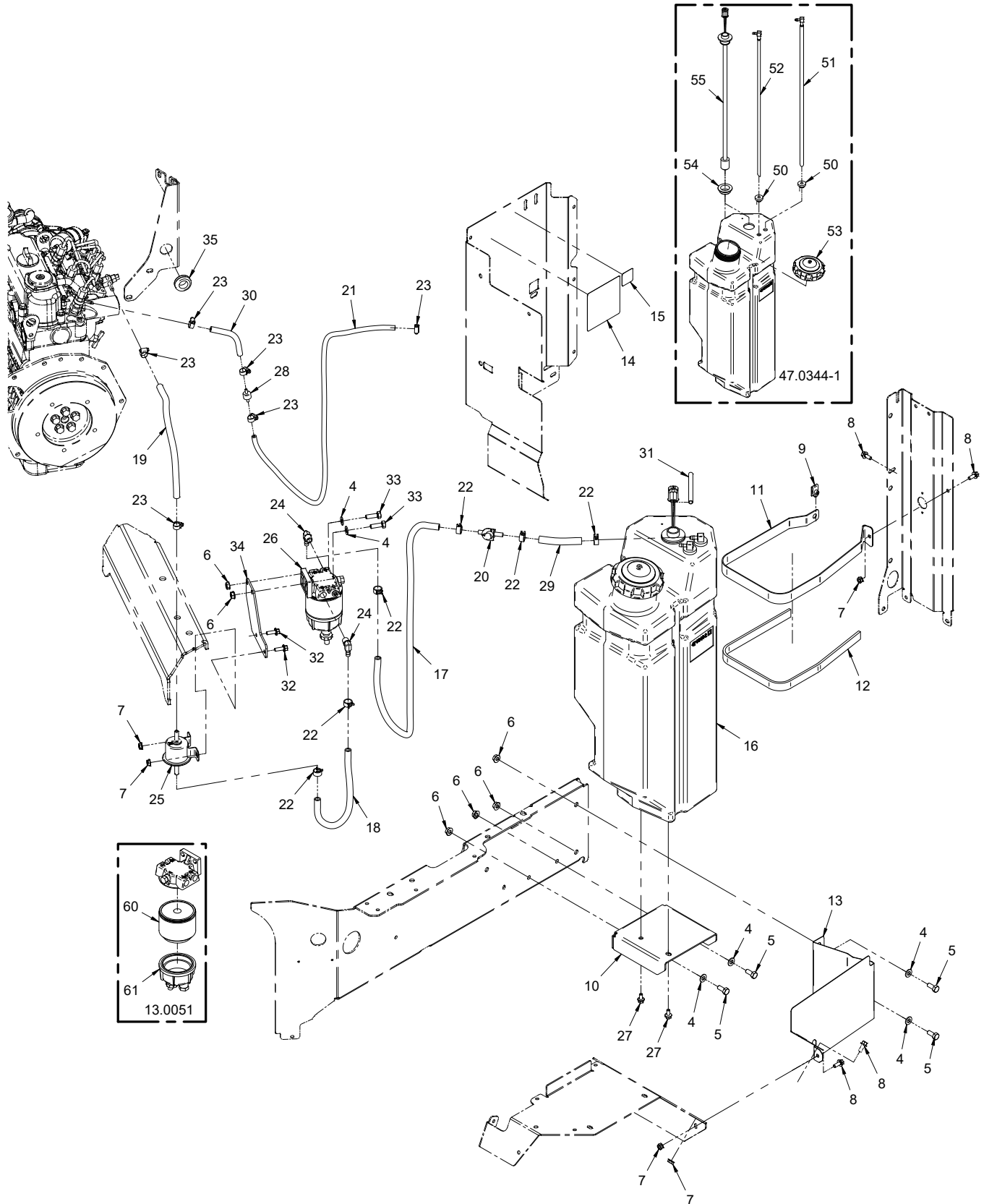

ENGINE

Fuel System

REF.	PART NO.	DESCRIPTION	QTY.
4	95.05	.WASHER, FLAT 5/16 SAE	6
5	90.0506	.BOLT, 5/16-18 USS X 3/4"	4
6	99.SF05	.NUT, SRF 5/16-18 USS	6
7	99.SF04	.NUT, SRF 1/4-20 USS	5
8	99.SF0405-1	.BOLT, SMF 1/4-20 X 5/8	4
9	99.E0046	.NUT, "U" 1/4-20 EXTRUDED	1
10	64.1790	.MOUNT, FUEL TANK BASE	1
11	64.1825	.STRAP, FUEL TANK	1
12	06.0047-27IN	.WEATHERSTRIP, 3/16 X 3/4 X 27"	1
13	60.1242	.COVER, FUEL TANK	1
14	00.0368	.DECAL, DIESEL ONLY	1
15	00.0334	.DECAL, FUEL ON/OFF	1
16	47.0344-1	.TANK, ASM 3400 DIESEL	1
17	27.F05-42.5IN	.HOSE, FUEL LINE 5/16" X 42-1/2"	1
18	27.F05-11IN	.HOSE, FUEL LINE 5/16" X 11"	1
19	27.F05-11IN	.HOSE, FUEL LINE 5/16" X 11"	1
20	47.0328	.VALVE, FUEL SHUT OFF 5/16"	1
21	27.F03-34IN	.HOSE, FUEL LINE 3/16" X 34"	1
22	11.0048	.CLAMP, HOSE BAND 9/16" OD HOSE	6
23	11.0038	.CLAMP, HOSES S/S 7/32 - 5/8	6
24	29.BF05MP0490	.FITTING, 5/16 BARB X 1/4 MP 90	2
25	13.0270	.PUMP, FUEL KUB - Y	1
26	13.0051	.FILTER, FUEL ASSEMBLY (RACOR)	1
27	99.SF0404-1	.BOLT, SMF 1/4-20 X 1/2	2
28	13.1C010-42460	.VALVE, FUEL CHECK	1
29	27.F05-3.75IN	.HOSE, FUEL LINE X 5/16" X 3-3/4"	1
30	27.F03-6IN	.HOSE, FUEL LINE 3/16" X 6"	1
31	30.0130-4IN	.LOOM, SPLIT CORRUGATED 1/4 X 4"	1
32	99.SF0406	.BOLT, SRF 1/4-20 X 3/4	2
33	90.0508	.BOLT, 5/16-18 USS X 1"	2
34	64.1754	.MOUNT, FUEL FILTER	1
35	05.0045	.GROMMET, 3/4ID, 1 3/8OD, 1/2THK	1
50	05.0133	.GROMMET, TANK FITTING	2
51	29.0099	.FITTING, TANK 5/16 WITHDRAW	1
52	29.0098	.FITTING, TANK 3/16 RETURN	1
53	47.0414	.CAP, DIESEL 3-1/2" VENTED	1
54	05.0134	.GROMMET, TANK FUEL SENDER	1
55	35.0137	.SENDING UNIT, FUEL	1
60	13.0220	.FILTER, FUEL ELEMENT	1
61	13.0051-1	.BOWL, FILTER W/DRAIN & PLUG	1

AXLES, WHEELS, & DRIVE SYSTEMS

Front Transaxle Mount & Tires

REF.	PART NO.	DESCRIPTION	QTY.
1	05.0045	.GROMMET, 3/4ID, 1 3/8OD, 1/2THK	1
2	95.06	.WASHER, FLAT 3/8 SAE	8
3	95.05	.WASHER, FLAT 5/16 SAE	4
4	99.SF06	.NUT, SRF 3/8-16 USS	17
5	99.SF0606	.BOLT, SRF 3/8-16 USS X 3/4	13
6	90.0516	.BOLT, 5/16-18 USS X 2"	1
7	99.SF05	.NUT, SRF 5/16-18 USS	5
8	90.0624	.BOLT, 3/8-16 USS X 3	4
9	90.0524	.BOLT, 5/16-18 USS X 3"	4
10	64.1266	.BRACKET, AXLE REAR MOUNT	1
11	51.0061	.TRANSAXLE, FRONT HIGH SPEED	1
12	64.1267	.ANCHOR, FRONT SKID PLATE LEFT	1
13	64.1268	.ANCHOR, FRONT SKID PLATE RIGHT	1
14	62.1409	.FRAME, CONNECTOR ANCHOR	1
15	64.1789	.PLATE, SKID FRONT AXLE	1
16	64.1781	.PLATE, HUB SPACER	2
17	53.0150	.WHEEL, ASM 18X11-10 AT (Serial # 01001-02422)	2
17	53.0176	.WHEEL, ASM 18X11-10 AT (Serial # 02423-)	2
17	53.0153	.WHEEL, ASM 18X10.5-10 TURF (Optional)	2
18	99.E0001	.NUT, LUG 1/2-20 SAE	8
19	42.0569	.LINKAGE, NEUTRAL FRONT AXLE	1
20	95.04	.WASHER, FLAT 1/4 SAE	1
21	02.CP0306	.COTTER PIN, 3/32 X 3/4	1
22	00.0376	.DECAL, NEUTRAL	1
35	53.0151	.RIM, 10 X 8.5 4 BOLT	1
36	53.0152	.TIRE, 18 X 11-10 AT	1
40	53.0151	.RIM, 10 X 8.5 4 BOLT	1
41	53.0154	.TIRE, 18 X 10.5-10 TURF	1
45	53.0177	.RIM, 10 X 7 X 4 BOLT	1
46	53.0152	.TIRE, 18 X 11-10 AT	1

AXLES, WHEELS, & DRIVE SYSTEMS

ILLUSTRATED DRAWING 51.0061 Front Transaxle

314-1700

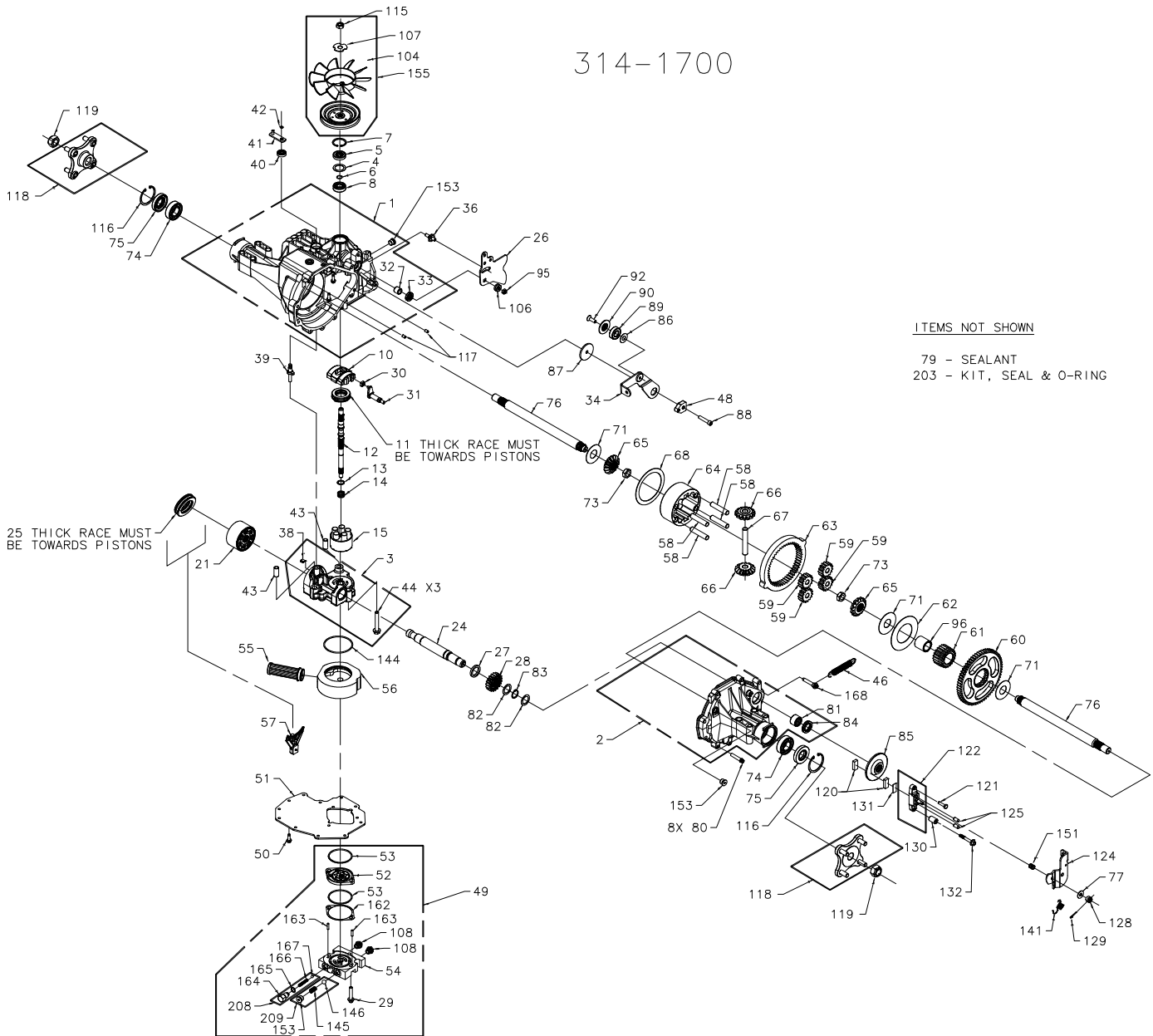

AXLES, WHEELS, & DRIVE SYSTEMS

51.0061 Front Transaxle

REF.	PART NO.	DESCRIPTION	QTY.
4	51.0079	.SPACER, .98 X 1.37 X .04	1
6	04.0038	.RING SET, 59 EXT WIRE	1
12	51.0077	.SHAFT, INPUT AUX	1
13	51.0078	.WASHER, THRUST .59 X .79 X .04	1
38	51.0035	.PLATE, BYPASS	1
41	51.0036	.ARM, BYPASS	1
42	04.0057	.RING, RETAINING 31 EXT	1
44	51.0037	.SCREW, 3/8-24 X 2.5	3
49	51.0054	.KIT, MANIFOLD AUXILIARY	1
51	51.0080	.PLATE, AUX COVER	1
53	26.0022	.O-RING, .103 X 2.425	2
55	51.0057	.FILTER, FRONT TRANSAXLE LT3000	1
56	51.0083	.MANIFOLD, CHARGE	1
74	55.0056	.BEARING, 1" X 52MM X 15MM	2
75	89.0068	.SEAL, LIP 25MM X 52MM X 10MM	2
76	51.0039	.SHAFT, AXLE	2
79	51.0040	.SEALANT	1
80	51.0041	.SCREW, TORX HEAD 5/16-18	8
84	89.0070	.SEAL, LIP .875 X 1.38 X .25	1
85	53.0147	.DISC, BRAKE	1
104	51.0066	.FAN, LH TRANSAXLES	1
118	51.0046	.HUB ASSEMBLY	2
119	99.A12NF	.LOCKNUT, STOVER 3/4-16 SAE	2
120	53.0145	.PAD, BRAKE DISC	2
131	53.0146	.PLATE, BRAKE DISC PAD	1
153	51.0068	.PLUG, 9/16-18 METAL	3
155	51.0067	.KIT, FAN/PULLEY	1
162	51.0052	.SHIM	1
166	51.0081	.SPRING, RELIEF HYDROGEAR	1
203	51.0049	.KIT, SEAL	1
210	51.0061	.TRANSAXLE, FRONT HIGH SPEED	1

Listed items are stocked. Check availability of unlisted parts.

AXLES, WHEELS, & DRIVE SYSTEMS

ILLUSTRATED DRAWING Rear Transaxle Mount & Tires

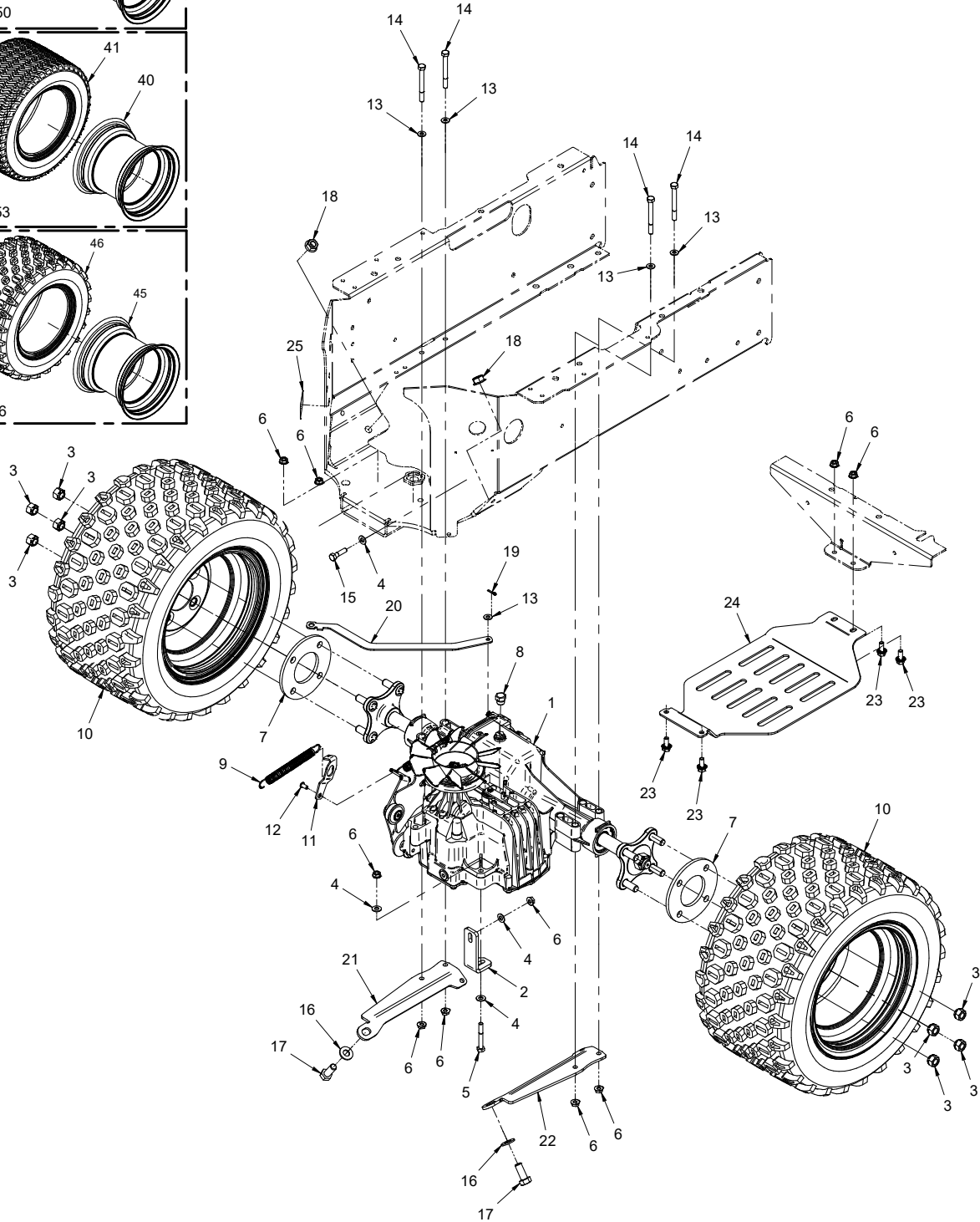
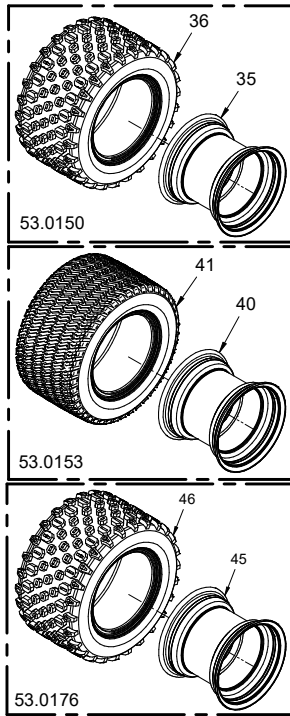

AXLES, WHEELS, & DRIVE SYSTEMS

Rear Transaxle Mount & Tires

REF.	PART NO.	DESCRIPTION	QTY.
1	51.0060	.TRANSAXLE, REAR HIGH SPEED	1
2	64.1805	.BRACE, TRANSAXLE SUPPORT	1
3	99.E0001	.NUT, LUG 1/2-20 SAE	8
4	95.05	.WASHER, FLAT 5/16 SAE	4
5	90.0518	.BOLT, 5/16-18 USS X 2-1/4"	1
6	99.SF05	.NUT, SRF 5/16-18 USS	10
7	64.1781	.PLATE, HUB SPACER	2
8	25.6408-06-SP	.FITTING, PLUG 6MB - DRILLED	1
9	41.0064	.SPRING, EXT. 3/4 X 3-1/2 OA LG	1
10	53.0150	.WHEEL, ASM 18X11-10 AT (Serial # 01001-02422)	2
10	53.0176	.WHEEL, ASM 18X11-10 AT (Serial # 02423-)	2
10	53.0153	.WHEEL, ASM 18X10.5-10 TURF (Optional)	2
11	64.1434	.BRACKET, SPRING RETAINER	1
12	99.0404	.BOLT, 1/4-20 X 1/2 BSCS	1
13	95.04	.WASHER, FLAT 1/4 SAE	5
14	90.0524	.BOLT, 5/16-18 USS X 3"	4
15	90.0510	.BOLT, 5/16-18 USS X 1-1/4"	1
16	95.08	.WASHER, FLAT 1/2 SAE	2
17	90.0810	.BOLT, 1/2-13 USS X 1-1/4	2
18	99.SF08	.NUT, SRF 1/2-13 USS	2
19	02.CP0306	.COTTER PIN, 3/32 X 3/4	1
20	42.0567	.LINKAGE, NEUTRAL REAR AXLE	1
21	64.1757	.BRACE, REAR AXLE RIGHT	1
22	64.1756	.BRACE, REAR AXLE LEFT	1
23	99.SF0506	.BOLT, SRF 5/16-18 USS X 3/4	4
24	64.1767	.PLATE, SKID REAR AXLE	1
25	00.0376	.DECAL, NEUTRAL	1
35	53.0151	.RIM, 10 X 8.5 4 BOLT	1
36	53.0152	.TIRE, 18 X 11-10 AT	1
40	53.0151	.RIM, 10 X 8.5 4 BOLT	1
41	53.0154	.TIRE, 18 X 10.5-10 TURF	1
45	53.0177	.RIM, 10 X 7 X 4 BOLT	1
46	53.0152	.TIRE, 18 X 11-10 AT	1

AXLES, WHEELS, & DRIVE SYSTEMS

ILLUSTRATED DRAWING 51.0060 Rear Transaxle

313-1700

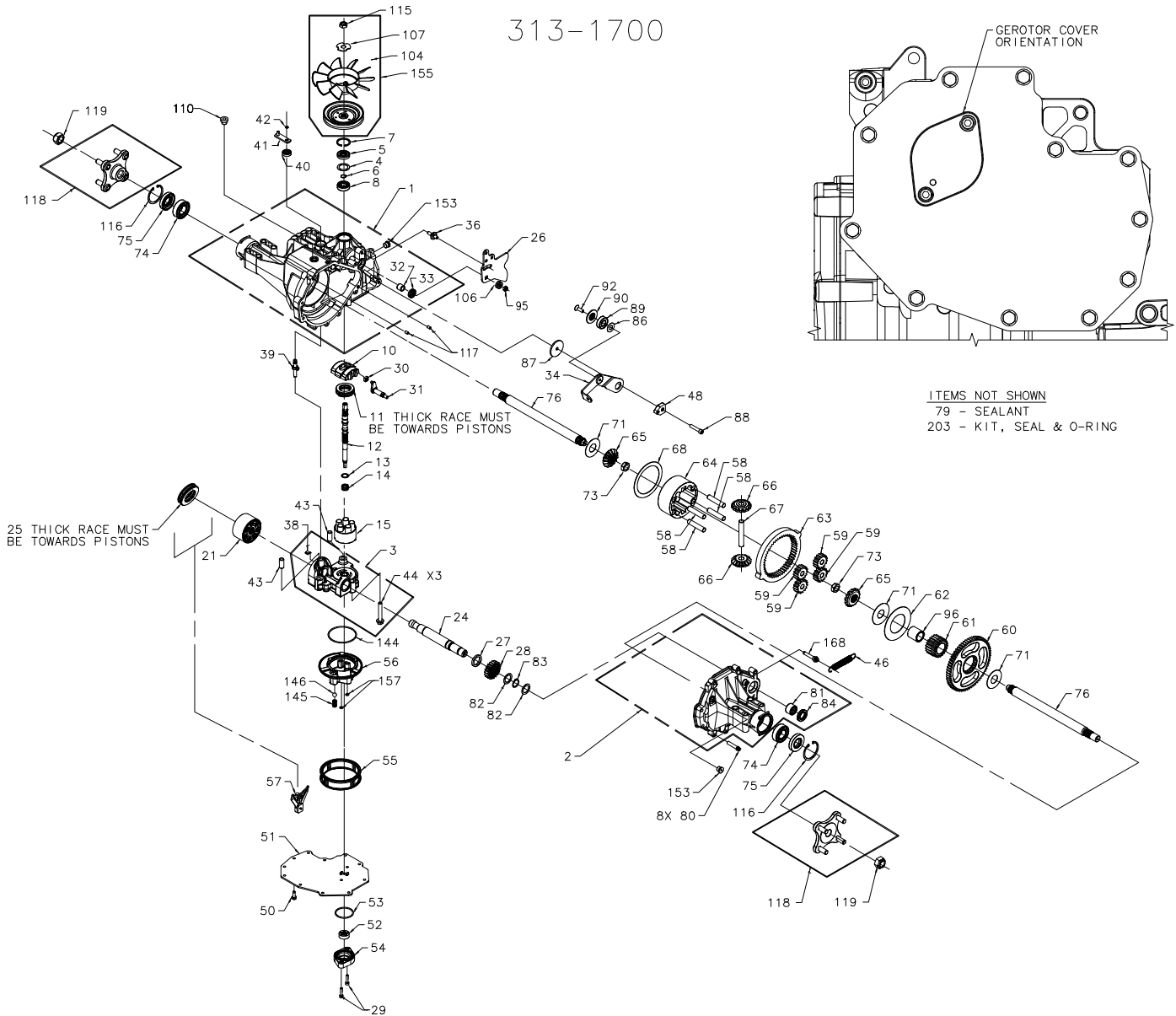

AXLES, WHEELS, & DRIVE SYSTEMS

51.0060 Rear Transaxle

REF.	PART NO.	DESCRIPTION	QTY.
4	51.0079	.SPACER, .98 X 1.37 X .04	1
6	04.0038	.RING SET, 59 EXT WIRE	1
12	51.0076	.SHAFT, INPUT	1
13	51.0078	.WASHER, THRUST .59 X .79 X .04	1
24	51.0034	.SHAFT, MOTOR	1
38	51.0035	.PLATE, BYPASS	1
41	51.0036	.ARM, BYPASS	1
42	04.0057	.RING, RETAINING 31 EXT	1
44	51.0037	.SCREW, 3/8-24 X 2.5	3
55	51.0038	.FILTER, REAR TRANSAXLE LT3000	1
74	55.0056	.BEARING, 1" X 52MM X 15MM	2
75	89.0068	.SEAL, LIP 25MM X 52MM X 10MM	2
76	51.0039	.SHAFT, AXLE	2
79	51.0040	.SEALANT	1
80	51.0041	.SCREW, TORX HEAD 5/16-18	8
84	89.0070	.SEAL, LIP .875 X 1.38 X .25	1
104	51.0066	.FAN, LH TRANSAXLES	1
110	25.6408-06-SP	.FITTING, PLUG 6MB - DRILLED	1
118	51.0046	.HUB ASSEMBLY	2
119	99.A12NF	.LOCKNUT, STOVER 3/4-16 SAE	2
153	51.0068	.PLUG, 9/16-18 METAL	2
155	51.0067	.KIT, FAN/PULLEY	1
203	51.0049	.KIT, SEAL	1
210	51.0060	.TRANSAXLE, REAR HIGH SPEED	1

Listed items are stocked. Check availability of unlisted parts.

AXLES, WHEELS, & DRIVE SYSTEMS

ILLUSTRATED DRAWING Belt & Pulley Diagram

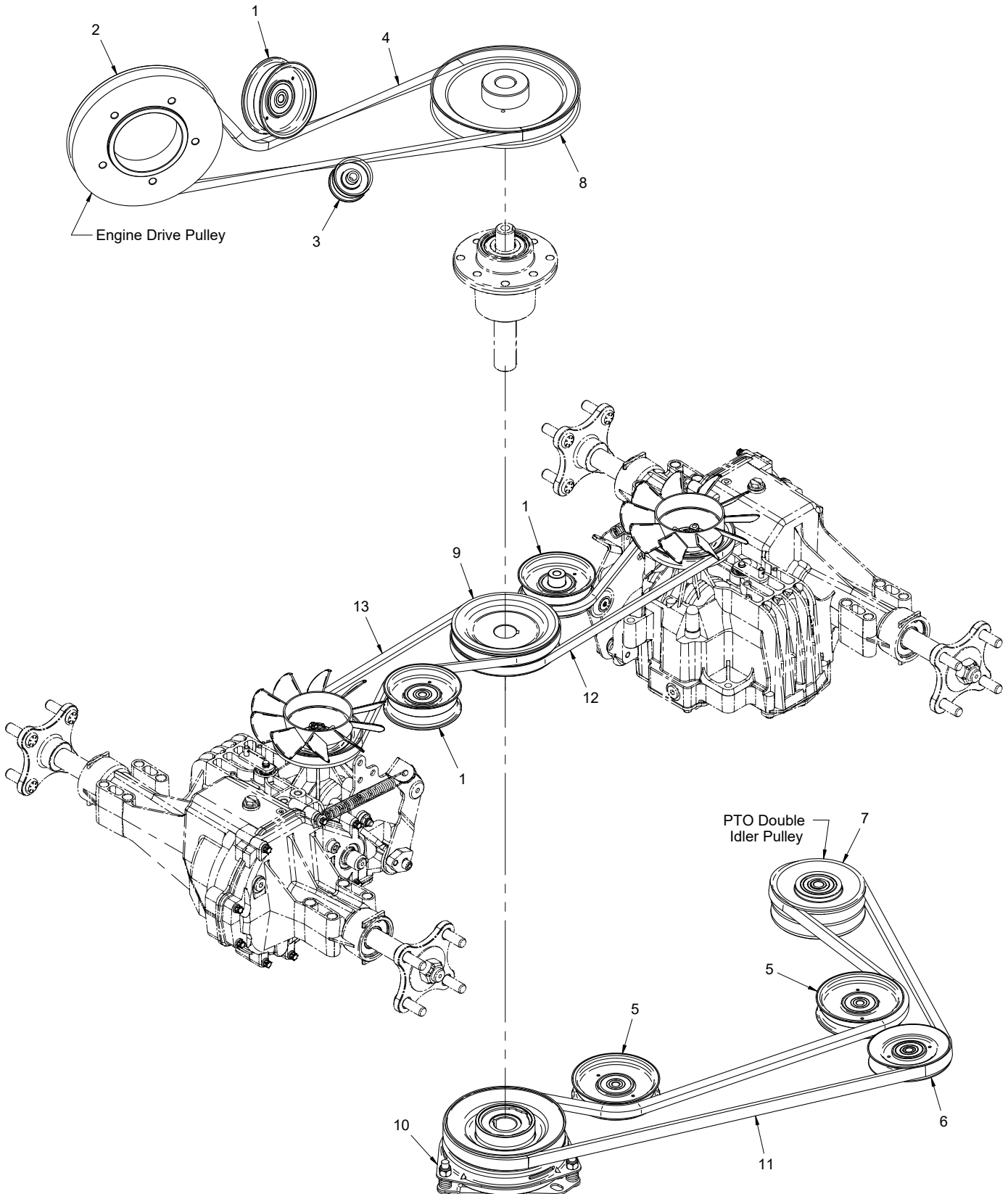

AXLES, WHEELS, & DRIVE SYSTEMS

Belt & Pulley Diagram

REF.	PART NO.	DESCRIPTION	QTY.
1	83.0013	.PULLEY, IDLER FLAT 3/8 X 3 1/2	3
2	83.0063	.PULLEY, ENGINE DRIVE	1
3	83.0068	.PULLEY, IDLER FLAT 3/8 X 2	1
4	81.0156	.BELT, B64.5 CUSTOM	1
5	83.0037	.PULLEY, IDLER FLAT 4" X 3/8.	2
6	83.0038	.PULLEY, V-IDLER 4-1/4 X 3/8 ID	1
7	83.0039	.PULLEY, IDLER 2 GROOVE ASM.	1
8	83.0052	.PULLEY, 7-1/2, 25MM STR. BORE (Serial # 01001-02071).	1
8	83.0065	.PULLEY, 7-1/2, 25MM STR BORE (Serial # 02072-).	1
9	83.0067	.PULLEY, LH CENTER STACK.	1
10	37.0061	.CLUTCH, ELECTRIC OGURA GT2.5	1
11	81.B089	.BELT, B89	1
12	81.A041	.BELT, A41	1
13	81.A041	.BELT, A41	1

AXLES, WHEELS, & DRIVE SYSTEMS

ILLUSTRATED DRAWING Main Drive From Engine

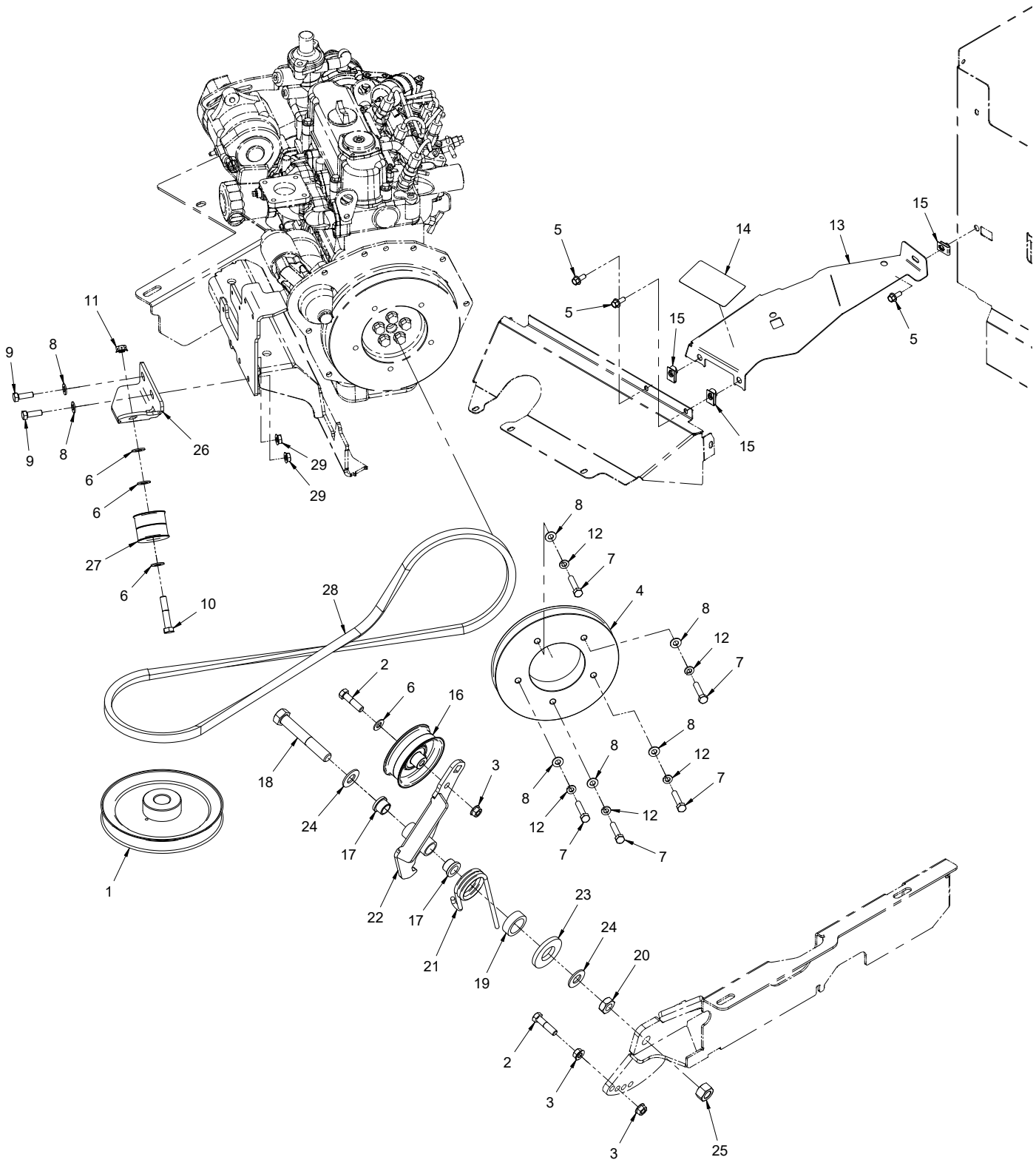

AXLES, WHEELS, & DRIVE SYSTEMS

Main Drive From Engine

REF.	PART NO.	DESCRIPTION	QTY.
1	83.0052	.PULLEY,7-1/2, 25MM STR. BORE (Serial # 01001-02071).	1
1	83.0065	.PULLEY, 7-1/2, 25MM STR BORE (Serial # 02072-).	1
2	90.0612	.BOLT, 3/8-16 USS X 1-1/2.	2
3	99.SF06	.NUT, SRF 3/8-16 USS.	3
4	83.0063	.PULLEY, ENGINE DRIVE	1
5	99.SF0405-1	.BOLT, SMF 1/4-20 X 5/8	3
6	95.06	.WASHER, FLAT 3/8 SAE	4
7	99.M0040	.BOLT, M8 X 1.25 X 40MM.	5
8	95.05	.WASHER, FLAT 5/16 SAE	7
9	90.0508	.BOLT, 5/16-18 USS X 1"	2
10	90.0616	.BOLT, 3/8-16 USS X 2.	1
11	99.E0082	.NUT, LOCKING FLANGE 3/8-16	1
12	96.05	.WASHER, LOCK 5/16.	5
13	60.1203	.COVER, ENGINE DRIVE BELT.	1
14	00.0369	.DECAL, DO NOT REMOVE SHIELDS	1
15	99.E0046	.NUT, "U" 1/4-20 EXTRUDED	3
16	83.0013	.PULLEY, IDLER FLAT 3/8 X 3 1/2	1
17	85.B0065	.BUSHING, 5/8ID X 13/16OD X5/8L	2
18	90.1032	.BOLT, 5/8-11 USS X 4.	1
19	64.1806	.BUSHING, TORSION SPRING	1
20	99.E0076	.NUT, JAM 5/8-11 USS.	1
21	41.0100	.SPRING, TORSION 1-5/8 X 6-1/2	1
22	40.0392	.IDLER ARM, ENGINE DRIVE	1
23	99.B0110	.WASHER, 1.094 X 2-1/4 X 1/4T	1
24	95.10	.WASHER, FLAT 5/8 SAE	2
25	92.10	.NUT, 5/8-11 USS	1
26	64.1798	.MOUNT, GUIDE PULLEY.	1
27	83.0068	.PULLEY, IDLER FLAT 3/8 X 2	1
28	81.0156	.BELT, B64.5 CUSTOM	1
29	99.SF05	.NUT, SRF 5/16-18 USS (Serial # 01001-01154).	2

AXLES, WHEELS, & DRIVE SYSTEMS

ILLUSTRATED DRAWING Center Drive Shaft & Clutch

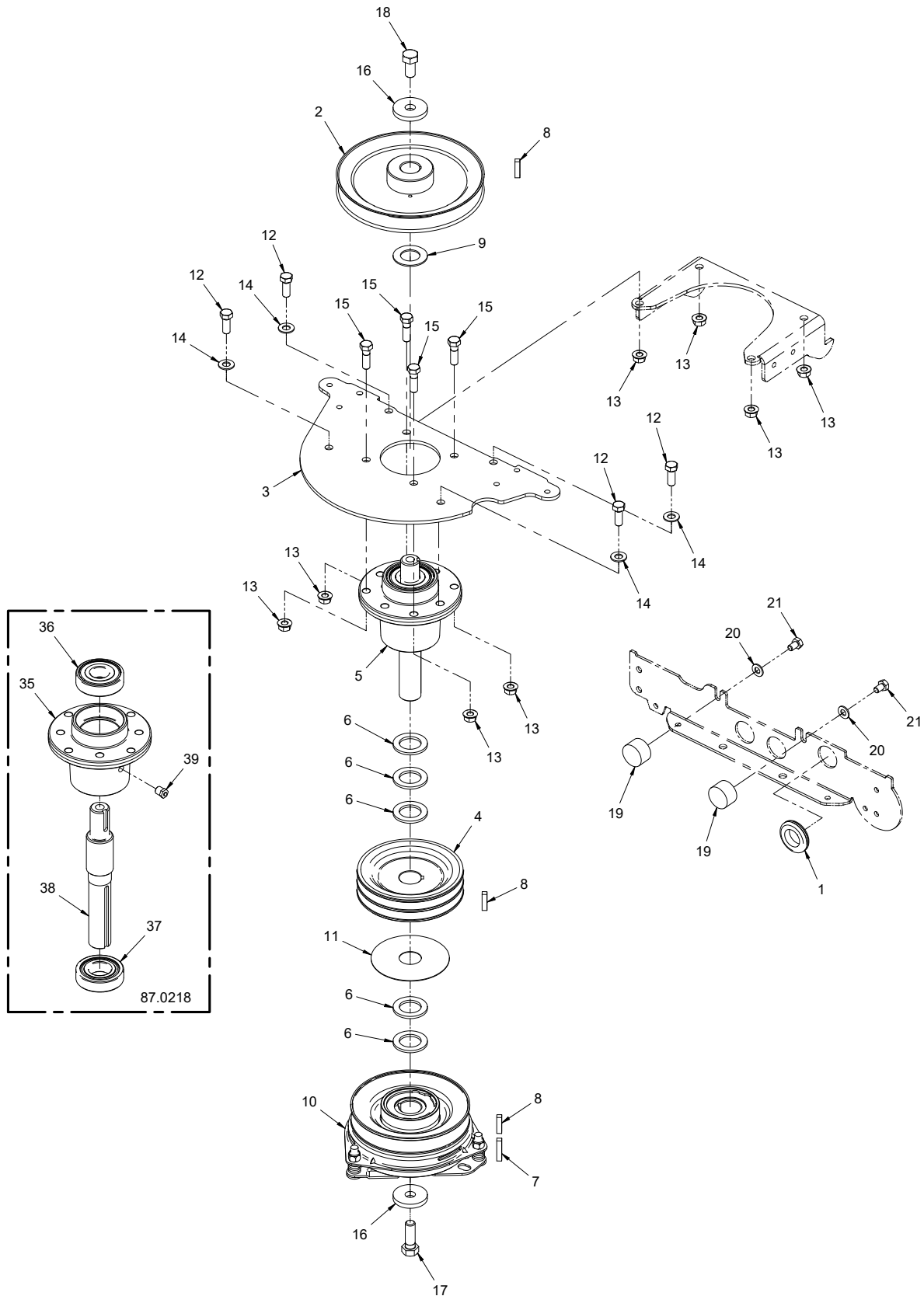

AXLES, WHEELS, & DRIVE SYSTEMS

Center Drive Shaft & Clutch

REF.	PART NO.	DESCRIPTION	QTY.
1	05.0044	.GROMMET, 1 ID, 1-3/4OD, 3/8THK	1
2	83.0052	.PULLEY,7-1/2, 25MM STR. BORE (Serial # 01001-02071)	1
2	83.0065	.PULLEY, 7-1/2, 25MM STR BORE (Serial # 02072-)	1
3	64.1766	.MOUNT, CENTER SPINDLE	1
4	83.0067	.PULLEY, LH CENTER STACK	1
5	87.0218	.SPINDLE, ASM LE CENTER SHAFT	1
6	99.B0059	.WASHER, MACH 1 1/8 X 10 GA	5
7	85.K0410	.KEY, 1/4 X 1-1/4	1
8	85.K0408	.KEY, 1/4 X 1	3
9	99.B0013	.WASHER, MACH 1" ID 14 GA	1
10	37.0061	.CLUTCH, ELECTRIC OGURA GT2.5	1
11	60.1204	.COVER, PTO CLUTCH BEARING	1
12	90.0608	.BOLT, 3/8-16 USS X 1	4
13	99.SF06	.NUT, SRF 3/8-16 USS	8
14	95.06	.WASHER, FLAT 3/8 SAE	4
15	90.0610	.BOLT, 3/8-16 USS X 1-1/4	4
16	99.B0064	.WASHER, 1/4 X 1.75 X .531 HOLE	2
17	91.0812	.BOLT, 1/2-20 SAE X 1-1/2	1
18	91.0808	.BOLT, 1/2-20 SAE X 1	1
19	05.0118	.BUMPER, RUBBER CYLINDRICAL	2
20	95.05	.WASHER, FLAT 5/16 SAE	2
21	90.0504	.BOLT, 5/16-18 USS X 1/2"	2
35	87.0209-1	.SPINDLE, HOUSING	1
36	55.0057	.BEARING, BALL 25 MM X 62 MM	1
37	55.0070	.BEARING, 30MM X 62MM X 16MM	1
38	87.0218-2	.SHAFT, LE CENTER SPINDLE	1
39	29.GF0017	.FITTING, RELIEF	1

AXLES, WHEELS, & DRIVE SYSTEMS

ILLUSTRATED DRAWING Center Drive Shaft Shields

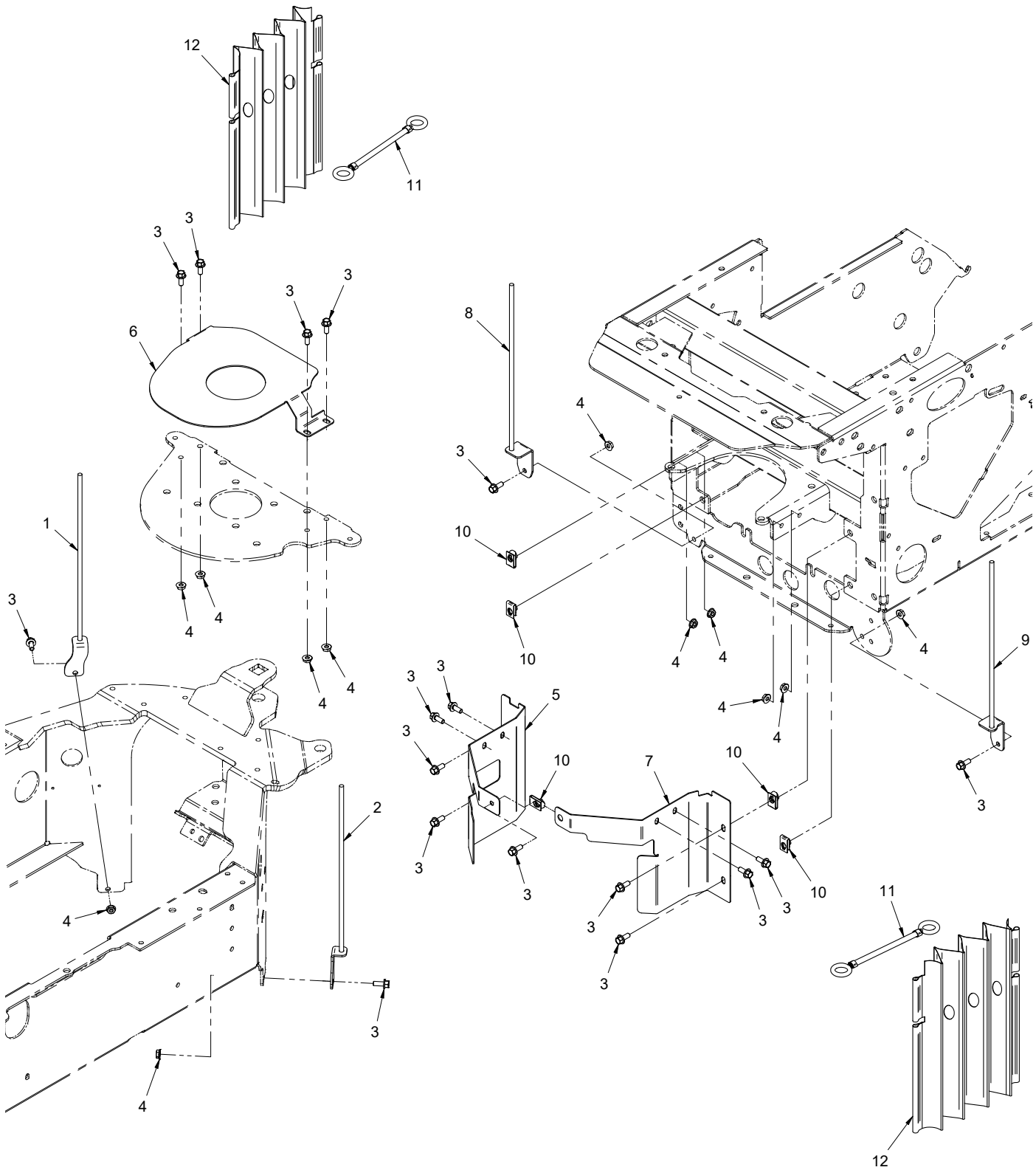

AXLES, WHEELS, & DRIVE SYSTEMS

Center Drive Shaft Shields

REF.	PART NO.	DESCRIPTION	QTY.
1	64.1809	.PIN, CANVAS REAR LEFT	1
2	64.1814	.PIN, CANVAS REAR RIGHT	1
3	99.SF0405-1	.BOLT, SMF 1/4-20 X 5/8	17
4	99.SF04	.NUT, SRF 1/4-20 USS.	12
5	60.1213	.GUARD, CENTER PIVOT LEFT	1
6	60.1215	.GUARD, CENTER PIVOT TOP	1
7	60.1214	.GUARD, CENTER PIVOT RIGHT	1
8	64.1807	.PIN, CANVAS FRONT LEFT	1
9	64.1808	.PIN, CANVAS FRONT RIGHT	1
10	99.E0046	.NUT, "U" 1/4-20 EXTRUDED	5
11	47.0448	.STRAP, BUNGEE	2
12	44.0332	.CANVAS, CENTER PIVOT	2

AXLES, WHEELS, & DRIVE SYSTEMS

ILLUSTRATED DRAWING Transaxle Drive

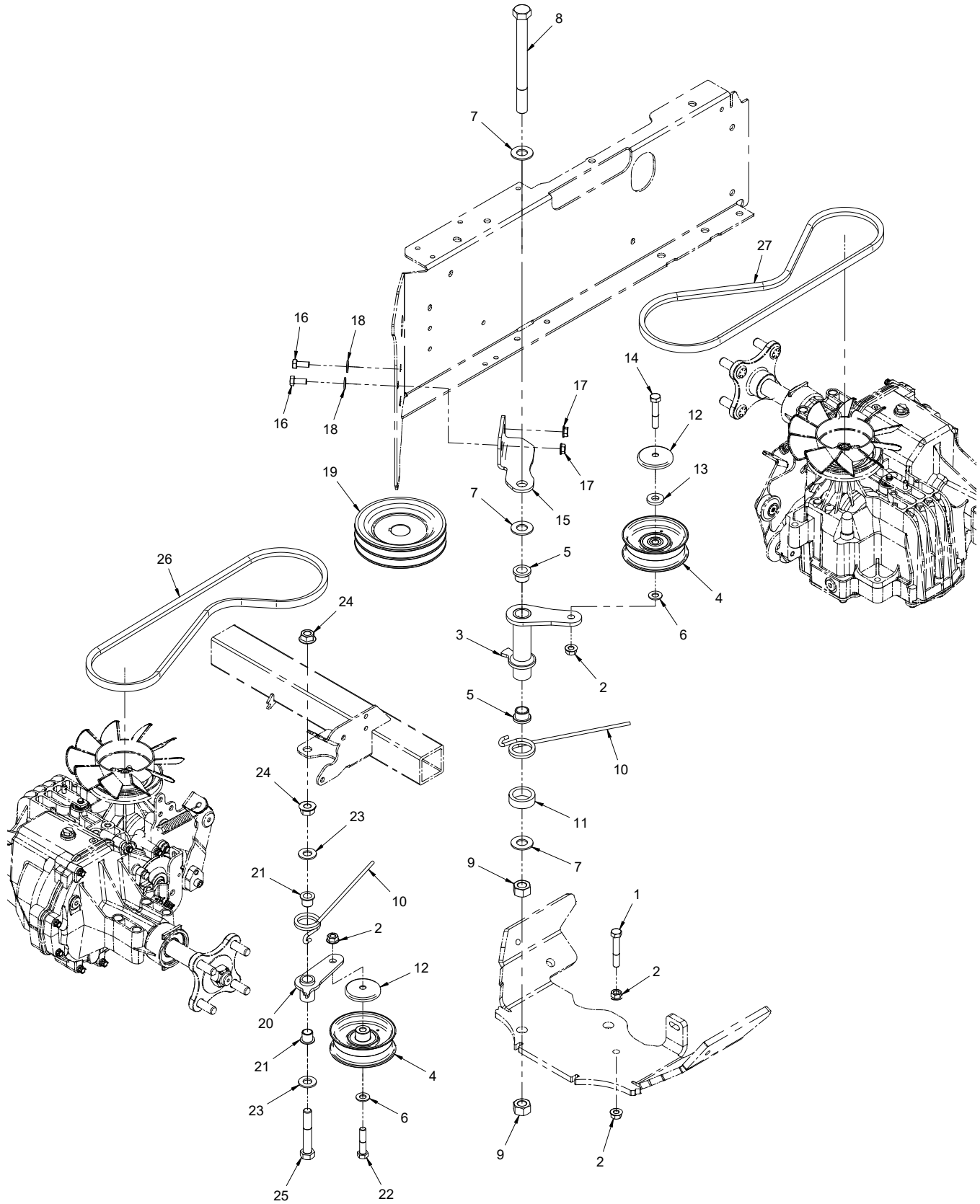

AXLES, WHEELS, & DRIVE SYSTEMS

Transaxle Drive

REF.	PART NO.	DESCRIPTION	QTY.
1	90.0618	.BOLT, 3/8-16 USS X 2-1/4	1
2	99.SF06	.NUT, SRF 3/8-16 USS	4
3	40.0395	.IDLER ARM, TRANSAXLE REAR	1
4	83.0013	.PULLEY, IDLER FLAT 3/8 X 3 1/2	2
5	85.B0065	.BUSHING, 5/8ID X 13/16OD X5/8L	2
6	95.06	.WASHER, FLAT 3/8 SAE	2
7	95.10	.WASHER, FLAT 5/8 SAE	3
8	90.1056	.BOLT, 5/8-11 USS X 7	1
9	92.10	.NUT, 5/8-11 USS	2
10	41.0083	.SPRING, TORSION RH 1-3/16 IDX7	2
11	64.1806	.BUSHING, TORSION SPRING	1
12	60.1056	.COVER, PULLEY	2
13	99.G0014	.WASHER, 3/8 USS FW .165 THK (Serial # 01001-02184)	1
14	90.0616	.BOLT, 3/8-16 USS X 2	1
15	64.1826	.SUPPORT, REAR DRIVE IDLER	1
16	90.0506	.BOLT, 5/16-18 USS X 3/4"	2
17	99.SF05	.NUT, SRF 5/16-18 USS	2
18	95.05	.WASHER, FLAT 5/16 SAE	2
19	83.0067	.PULLEY, LH CENTER STACK	1
20	40.0356	.ARM, DRIVE BLT FT AXLE IDLER	1
21	85.B0027	.BUSHING, 1/2 ID X 5/8 OD X 5/8	2
22	90.0614	.BOLT, 3/8-16 USS X 1-3/4	1
23	95.08	.WASHER, FLAT 1/2 SAE	2
24	99.SF08	.NUT, SRF 1/2-13 USS	2
25	90.0824	.BOLT, 1/2-13 USS X 3	1
26	81.A041	.BELT, A41	1
27	81.A041	.BELT, A41	1

AXLES, WHEELS, & DRIVE SYSTEMS

ILLUSTRATED DRAWING PTO Drive

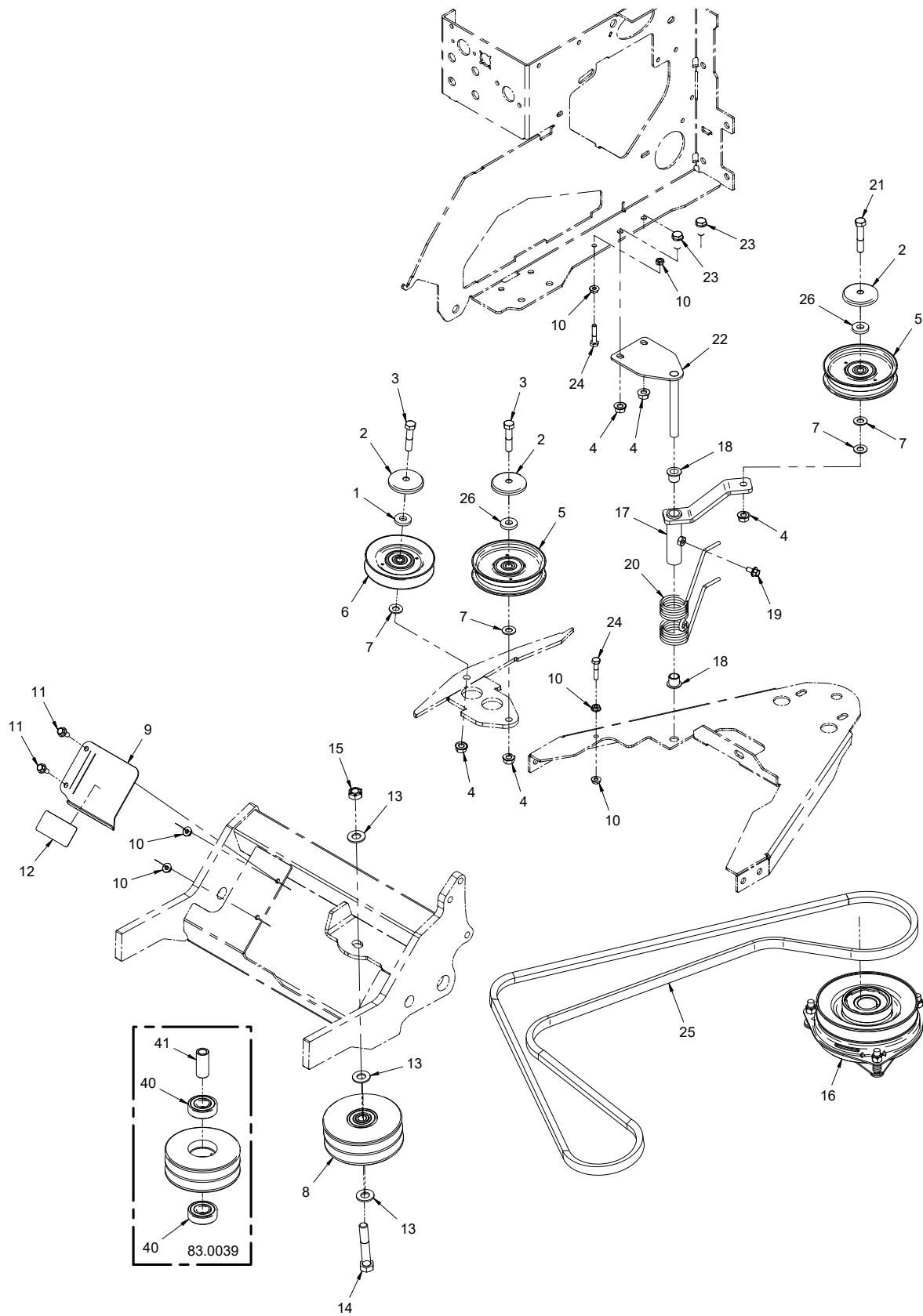

AXLES, WHEELS, & DRIVE SYSTEMS

PTO Drive

REF.	PART NO.	DESCRIPTION	QTY.
1	99.G0014	.WASHER, 3/8 USS FW .165 THK (Serial # 01001-02141)	1
2	60.1056	.COVER, PULLEY	3
3	90.0614	.BOLT, 3/8-16 USS X 1-3/4	2
4	99.SF06	.NUT, SRF 3/8-16 USS	5
5	83.0037	.PULLEY, IDLER FLAT 4" X 3/8	2
6	83.0038	.PULLEY, V-IDLER 4-1/4 X 3/8 ID	1
7	95.06	.WASHER, FLAT 3/8 SAE	4
8	83.0039	.PULLEY, IDLER 2 GROOVE ASM	1
9	60.0973	.SHIELD, FRONT DOUBLE IDLER BELT	1
10	99.SF04	.NUT, SRF 1/4-20 USS	6
11	99.SF0405-1	.BOLT, SMF 1/4-20 X 5/8	2
12	00.0365	.DECAL, WARNING MOVING PARTS	1
13	95.08	.WASHER, FLAT 1/2 SAE	3
14	90.0824	.BOLT, 1/2-13 USS X 3	1
15	99.A08	.LOCKNUT, STOVER 1/2-13 USS	1
16	37.0061	.CLUTCH, ELECTRIC OGURA GT2.5	1
17	40.0394	.ARM, PTO BELT IDLER	1
18	85.B0027	.BUSHING, 1/2 ID X 5/8 OD X 5/8	2
19	99.SF0404	.BOLT, SRF 1/4-20 X 1/2	1
20	41.0065	.SPRING, DOUBLE TORSION BLACK	1
21	90.0616	.BOLT, 3/8-16 USS X 2	1
22	64.0820	.ANCHOR, PLATE PTO IDLER	1
23	99.SF0606	.BOLT, SRF 3/8-16 USS X 3/4	2
24	90.0410	.BOLT, 1/4-20 USS X 1/1-4"	2
25	81.B089	.BELT, B89	1
26	99.G0014	.WASHER, 3/8 USS FW .165 THK (Serial # 01001-02105)	2
40	55.0042	.BEARING, BALL 20 MM X 47 MM	2
41	85.B0074	.BUSHING, DRIVE PULLEY	1

FRAMES / SHEET METAL

ILLUSTRATED DRAWING Rear Frame, Fenders, and Engine Side Panels

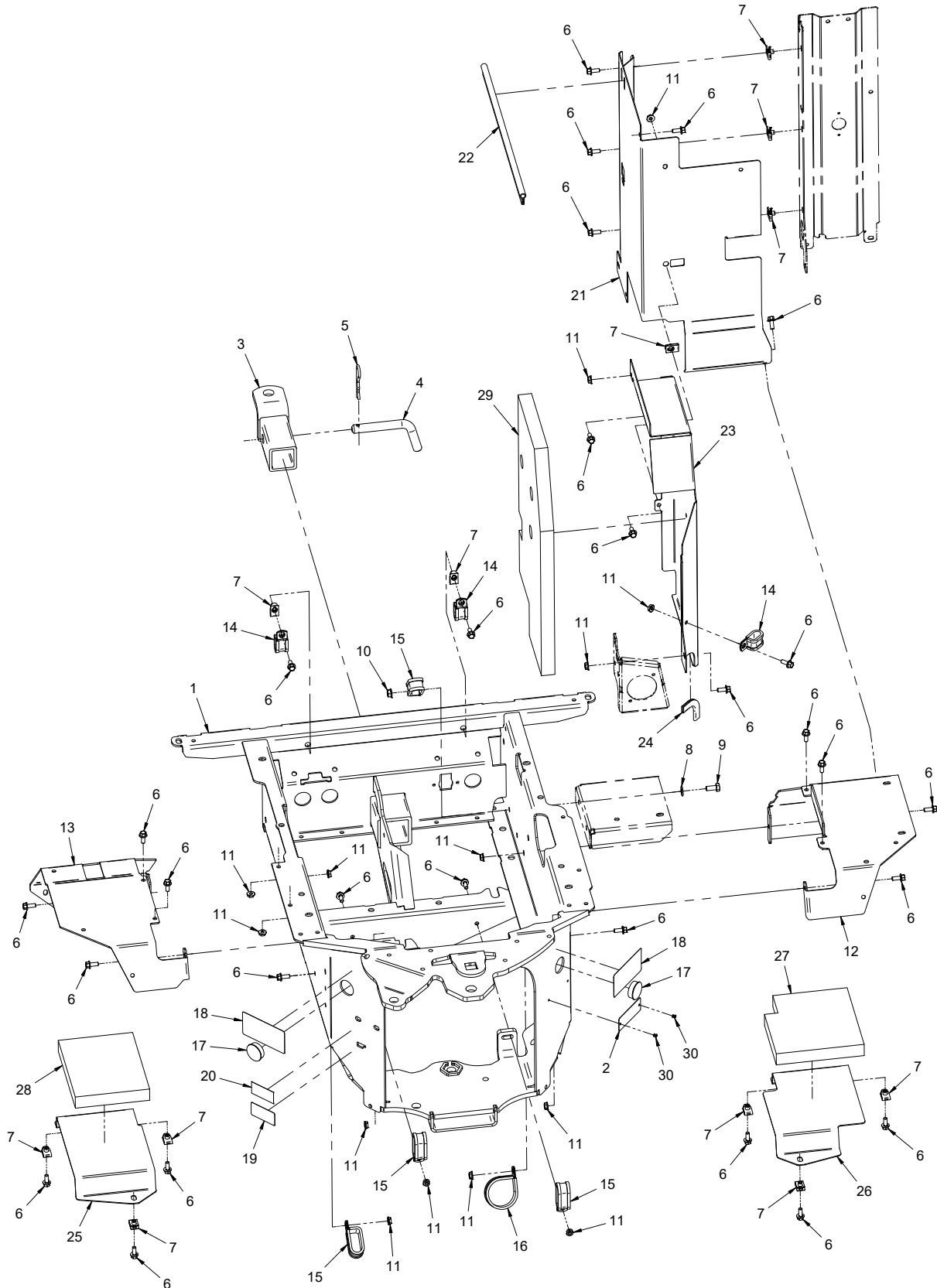

FRAMES / SHEET METAL

Rear Frame, Fenders, and Engine Side Panels

REF.	PART NO.	DESCRIPTION	QTY.
1	62.1402	.FRAME, REAR 3400	1
2	N/A	.PLATE, VENTRAC SERIAL NUMBER	1
3	62.0968	.HITCH, REAR	1
4	03.0014	.PIN, HITCH 5/8" X 3" USABLE	1
5	02.HP0524	.HAIRPIN, 5/32 X 3"	1
6	99.SF0405-1	.BOLT, SMF 1/4-20 X 5/8	29
7	99.E0046	.NUT, "U" 1/4-20 EXTRUDED	12
8	95.05	.WASHER, FLAT 5/16 SAE	1
9	90.0506	.BOLT, 5/16-18 USS X 3/4"	1
10	99.SF05	.NUT, SRF 5/16-18 USS	1
11	99.SF04	.NUT, SRF 1/4-20 USS	17
12	60.1189	.FENDER, REAR LEFT	1
13	60.1188	.FENDER, REAR RIGHT	1
14	11.0046	.CLAMP, CUSHIONED METAL 1/2"	3
15	11.0071	.CLAMP, CUSHIONED METAL 3/4"	4
16	11.0065	.CLAMP, CUSHIONED METAL 2"	1
17	05.0091	.PLUG, 1-1/4" HOLE, BLK PLASTIC	2
18	00.0369	.DECAL, DO NOT REMOVE SHIELDS	2
19	00.0376	.DECAL, NEUTRAL	1
20	00.0100	.DECAL, MADE IN USA	1
21	60.1194	.PANEL, TANK SURROUND LH3400Y	1
22	06.0043-16.5IN	.TRIM, TRIM SEAL W/BULB X 16-1/2"	1
23	60.1201	.PANEL, BATTERY CHAMBER 3400Y	1
24	06.0042-3.5IN	.TRIM, TRIM LOC 1/2 X 1/16 X 3-1/2"	1
25	60.1243	.COVER, FRAME REAR RIGHT	1
26	60.1244	.COVER, FRAME REAR LEFT	1
27	44.0345	.INSULATION, LOWER LEFT REAR	1
28	44.0344	.INSULATION, LOWER RIGHT REAR	1
29	44.0343	.INSULATION, BATTERY SHIELD	1
30	04.0007	.RIVET, POP DOME 1/8 X 1/8 S.S.	2

FRAMES / SHEET METAL

ILLUSTRATED DRAWING Hood Base Mount & Support Panels

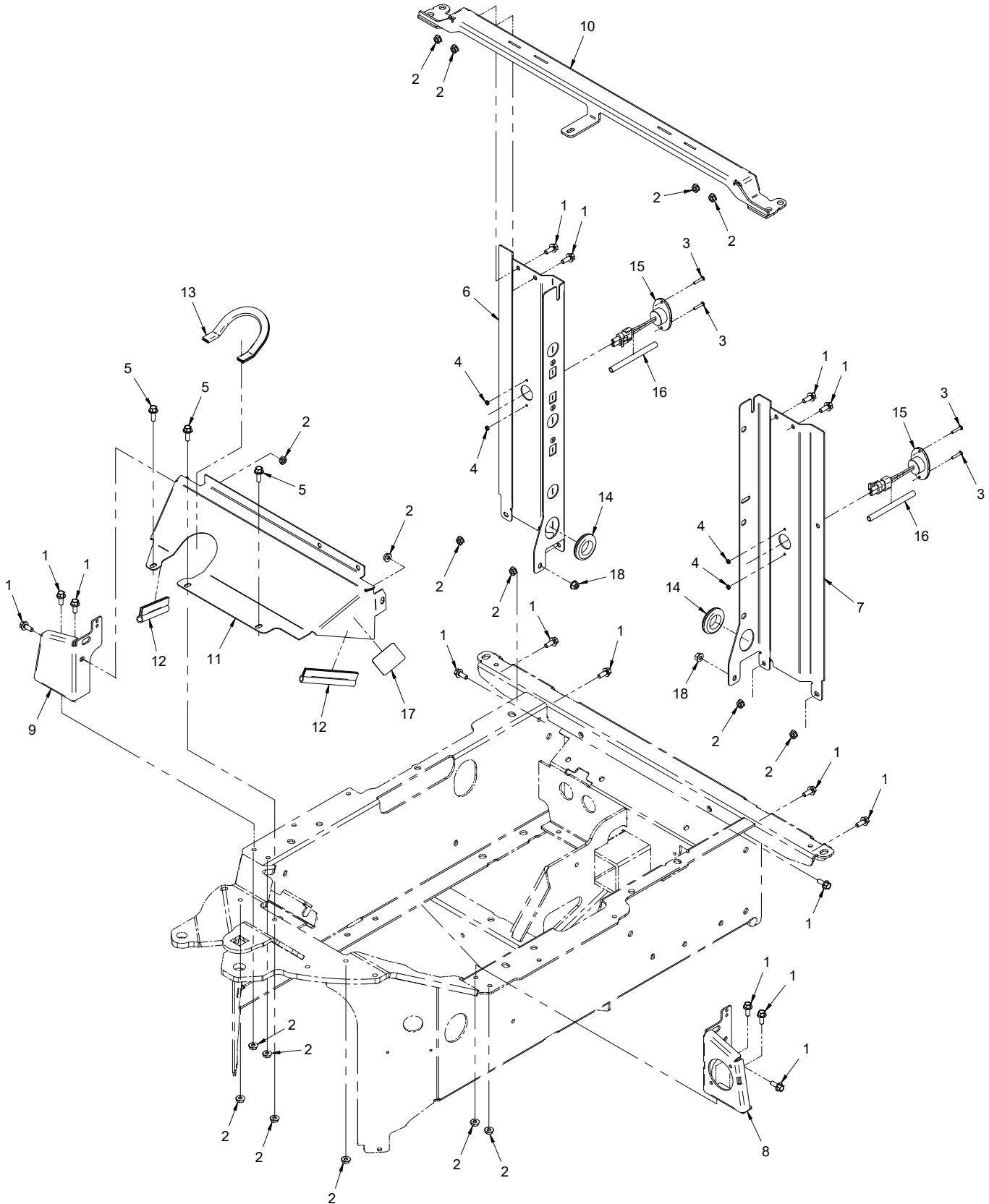

FRAMES / SHEET METAL

Hood Base Mount & Support Panels

REF.	PART NO.	DESCRIPTION	QTY.
1	99.SF0405-1	.BOLT, SMF 1/4-20 X 5/8	16
2	99.SF04	.NUT, SRF 1/4-20 USS	17
3	99.K0060	.MACHINE SCREW, #6-32 X 3/4	4
4	99.E0085	.LOCKNUT, NYLON #6-32	4
5	99.SF0406-1	.BOLT, SMF 1/4-20 X 3/4	3
6	64.1760	.SUPPORT, REAR RIGHT	1
7	64.1761	.SUPPORT, REAR LEFT	1
8	64.1787	.MOUNT, HOOD BASE LEFT	1
9	64.1788	.MOUNT, HOOD BASE RIGHT	1
10	64.1762	.SUPPORT, REAR TOP	1
11	60.1216	.COVER, HOOD FRONT	1
12	06.0043-4IN	.TRIM, TRIM SEAL W/BULB X 4"	2
13	06.0042-7.75IN	.TRIM, TRIM LOC 1/2 X 1/16 X 7-3/4"	1
14	05.0044	.GROMMET, 1 ID, 1-3/4OD, 3/8THK	2
15	33.0061	.LIGHT, MARKER RED OVAL	2
16	30.0130-8IN	.LOOM, SPLIT CORRUGATED 1/4 X 8"	2
17	00.0373	.DECAL, BATTERY DISCONNECT	1
18	99.E0101	.NUT, LOCKING FLANGE 1/4-20	2

FRAMES / SHEET METAL

ILLUSTRATED DRAWING Top & Rear Hood Panels

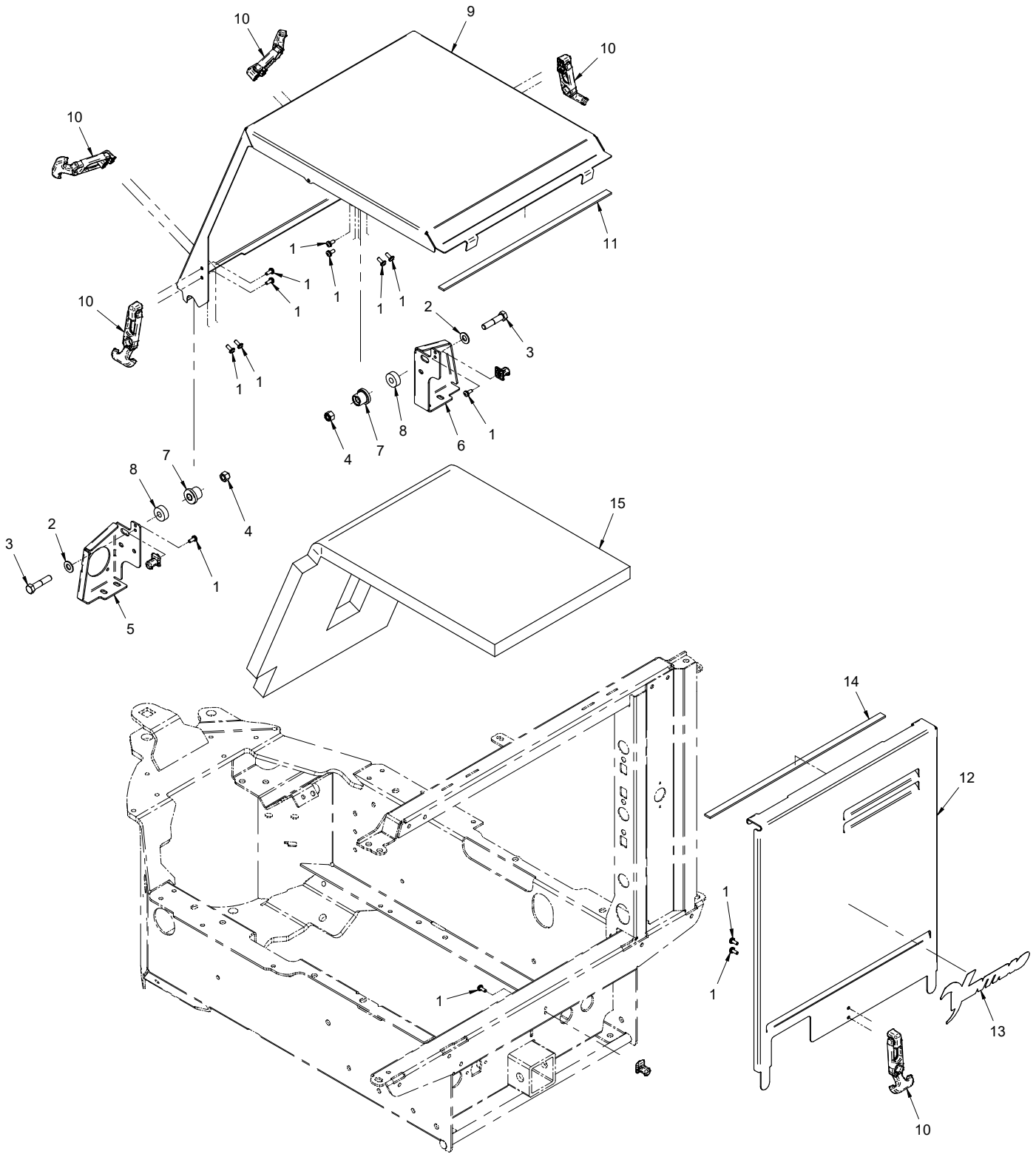

FRAMES / SHEET METAL

Top & Rear Hood Panels

REF.	PART NO.	DESCRIPTION	QTY.
1	99.K0072	.MACHINE SCREW, 10-24 X 1/2 ZP	13
2	95.06	.WASHER, FLAT 3/8 SAE	2
3	90.0614	.BOLT, 3/8-16 USS X 1-3/4	2
4	99.A06N	.LOCKNUT, NYLON 3/8-16 USS	2
5	64.1787	.MOUNT, HOOD BASE LEFT	1
6	64.1788	.MOUNT, HOOD BASE RIGHT	1
7	05.0150	.ISOLATOR, CENTER MOUNT	2
8	64.1821	.SPACER, 3/8 ID X 1" OD X 3/8T	2
9	60.1192	.PANEL, HOOD TOP	1
10	47.0127	.LATCH, RUBBER DRAW T-HANDLE	5
11	06.0078-16IN	.WEATHERSTRIP, 1/8 X 1/2 EPDM X 16"	1
12	60.1193	.PANEL, REAR	1
13	00.0383	.DECAL, VENTRAC	1
14	06.0078-16.75IN	.WEATHERSTRIP, 1/8 X 1/2 EPDM X 16-3/4"	1
15	44.0341	.INSULATION, HOOD CENTER	1

FRAMES / SHEET METAL

ILLUSTRATED DRAWING Left Hood Panel

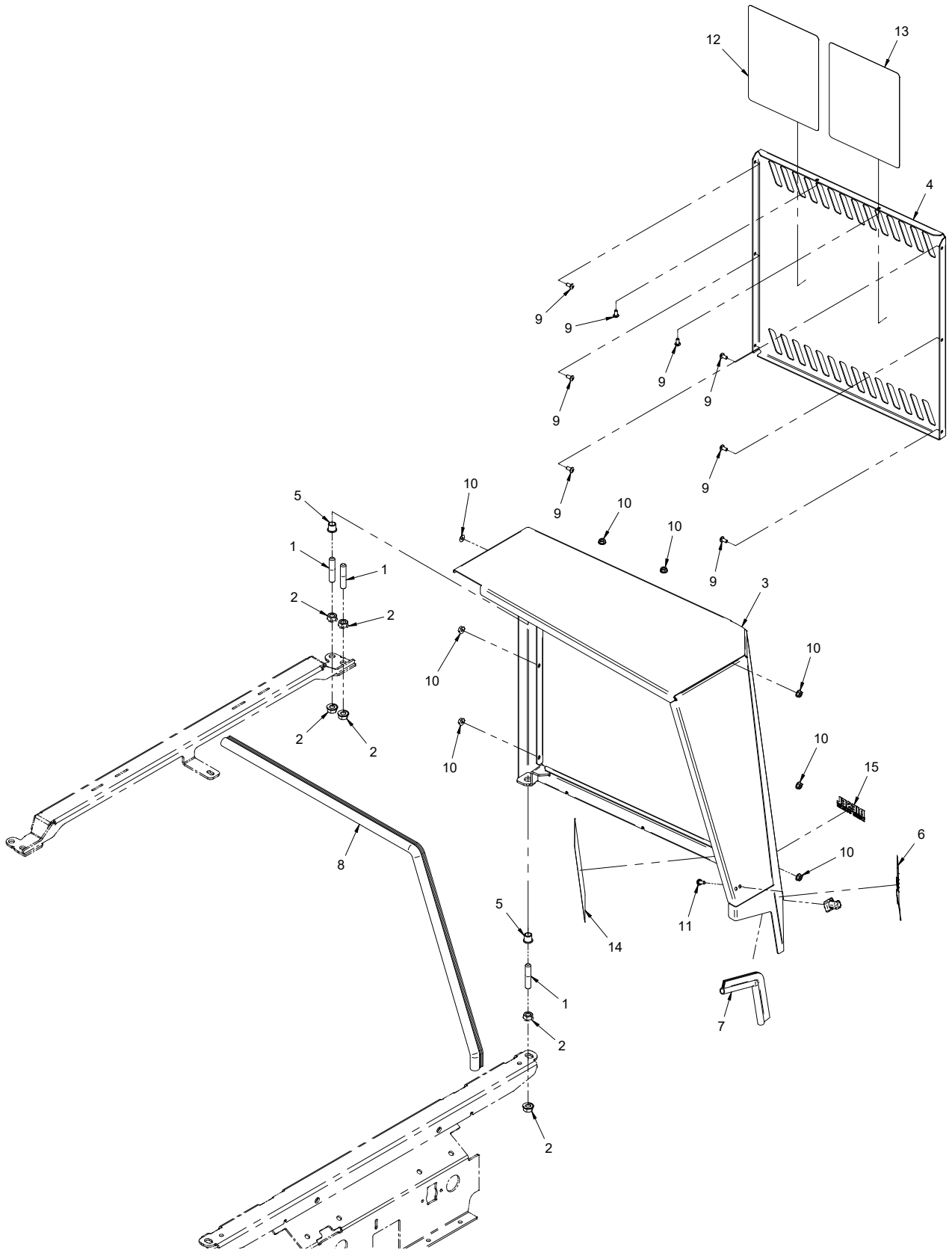

FRAMES / SHEET METAL

Left Hood Panel

REF.	PART NO.	DESCRIPTION	QTY.
1	99.F0043	.PIN, HINGE 3/8-16 X 1-7/8 SS	3
2	99.SF06	.NUT, SRF 3/8-16 USS	6
3	60.1190	.PANEL, HOOD LEFT	1
4	60.1218	.PANEL, HOOD INSERT LEFT	1
5	85.B0068	.BUSHING, 3/8 X 1/2 OD X 1/2 LG	2
6	00.0382	.DECAL, VENTRAC	1
7	06.0043-7.25IN	.TRIM, TRIM SEAL W/BULB X 7-1/4"	1
8	06.0077-33.5IN	.TRIM, TRIM SEAL W/BULB X 33-1/2"	1
9	99.K0042	.MACHINE SCREW, 10-32 X 3/8	8
10	99.E0035	.NUT, SRF #10-32	8
11	99.K0072	.MACHINE SCREW, 10-24 X 1/2 ZP	1
12	00.0353	.DECAL, QUICK REFERENCE	1
13	00.0354	.DECAL, MAINTENANCE	1
14	00.0385	.DECAL, MAINTENANCE ENG OIL	1
15	00.0322	.DECAL, DIESEL LIQUID COOLED	1

FRAMES / SHEET METAL

ILLUSTRATED DRAWING Right Hood Panel

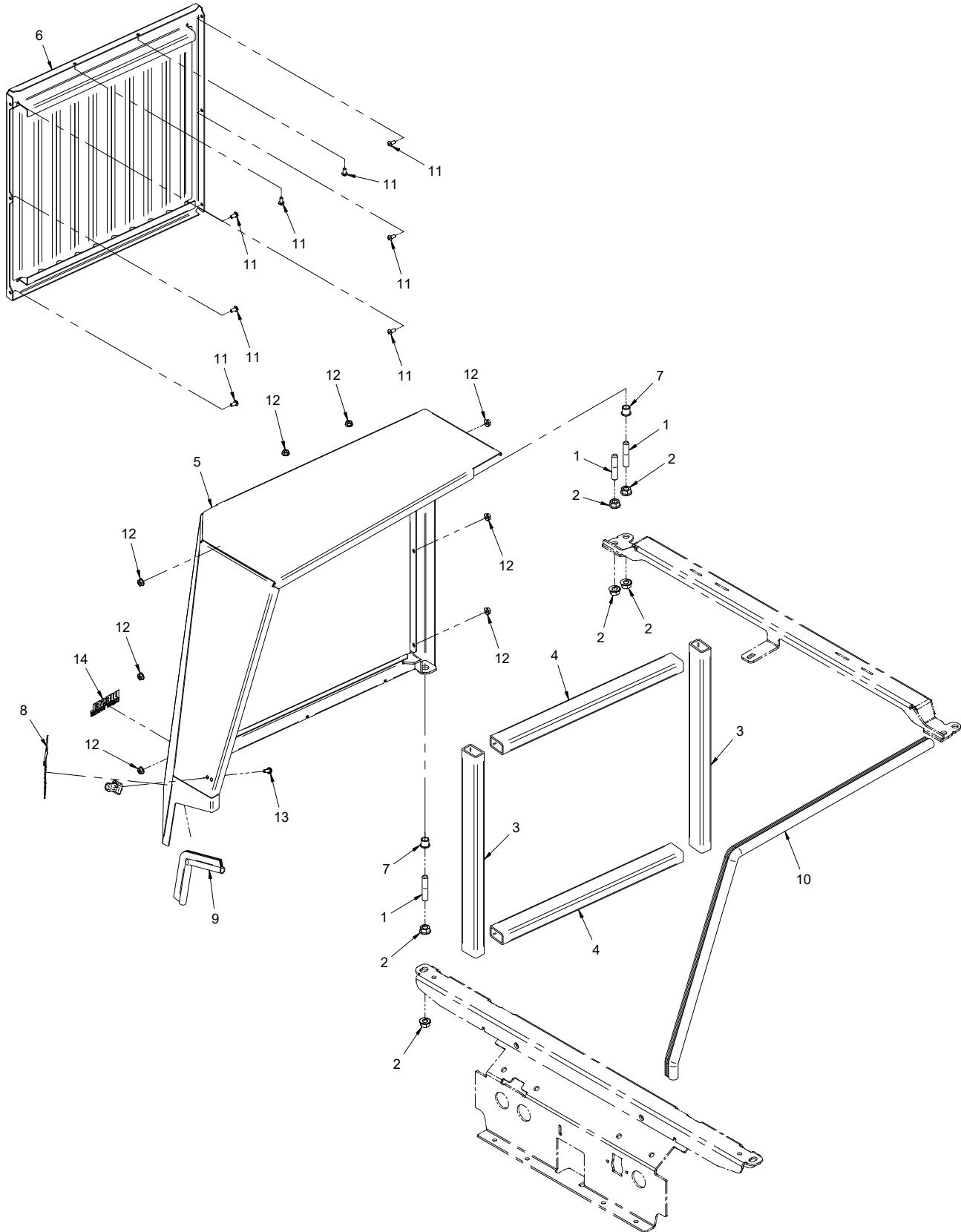

FRAMES / SHEET METAL

Right Hood Panel

REF.	PART NO.	DESCRIPTION	QTY.
1	99.F0043	.PIN, HINGE 3/8-16 X 1-7/8 SS	3
2	99.SF06	.NUT, SRF 3/8-16 USS	6
3	06.0079-16IN	.WEATHERSTRIP, 7/8"W X 1-3/8 T X 16"	2
4	06.0079-15IN	.WEATHERSTRIP, 7/8"W X 1-3/8 T X 15"	2
5	60.1191	.PANEL, HOOD RIGHT	1
6	64.1768	.SCREEN, HOOD RIGHT	1
7	85.B0068	.BUSHING, 3/8 X 1/2 OD X 1/2 LG	2
8	00.0382	.DECAL, VENTRAC	1
9	06.0043-7.25IN	.TRIM, TRIM SEAL W/BULB X 7-1/4"	1
10	06.0077-33.5IN	.TRIM, TRIM SEAL W/BULB X 33-1/2"	1
11	99.K0042	.MACHINE SCREW, 10-32 X 3/8	8
12	99.E0035	.NUT, SRF #10-32	8
13	99.K0072	.MACHINE SCREW, 10-24 X 1/2 ZP	1
14	00.0322	.DECAL, DIESEL LIQUID COOLED	1

FRAMES / SHEET METAL

ILLUSTRATED DRAWING Center Frame Pivot & Connector Link

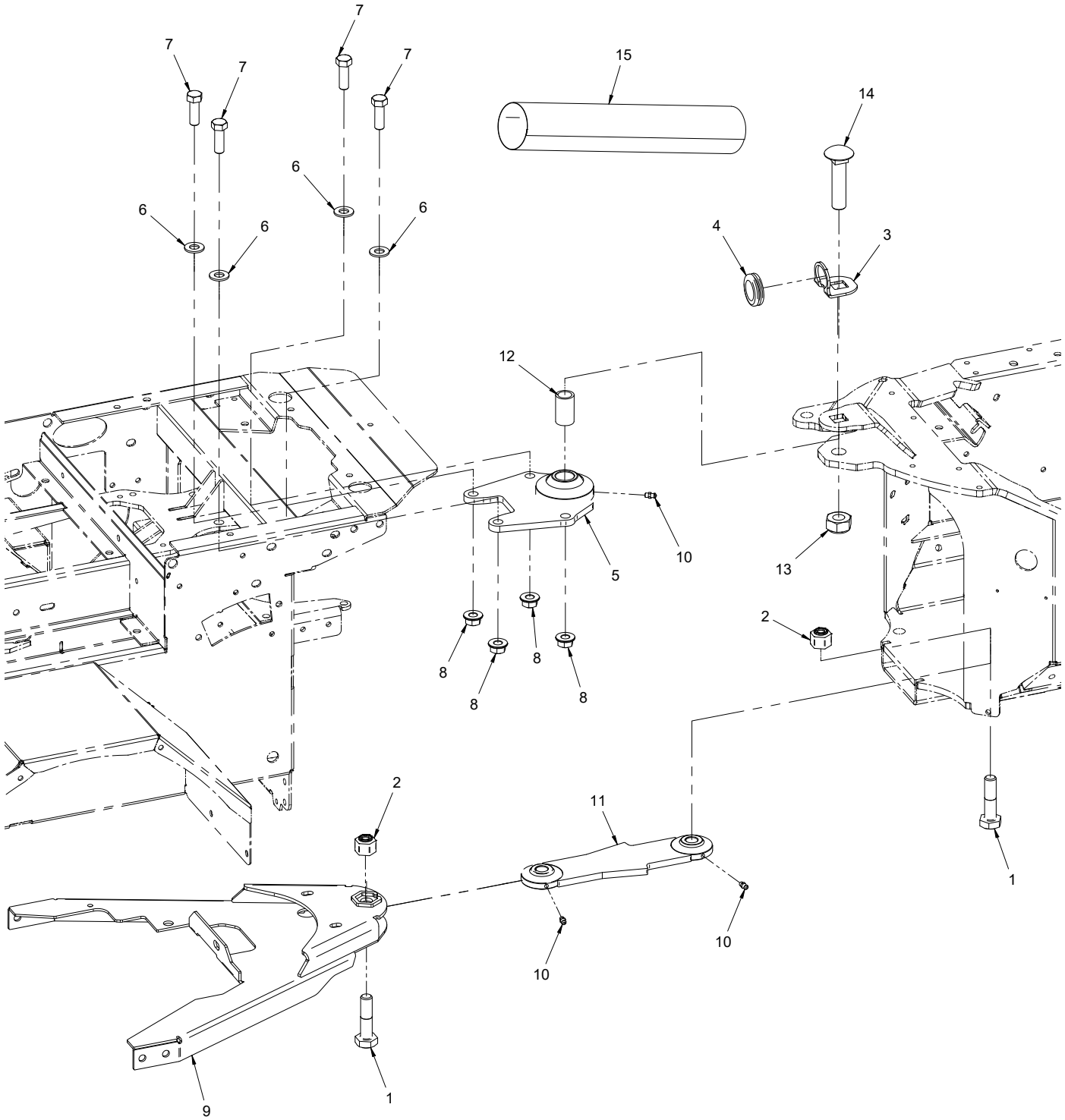

FRAMES / SHEET METAL

Center Frame Pivot & Connector Link

REF.	PART NO.	DESCRIPTION	QTY.
1	99.K0112	.BOLT, 5/8-11 X 2-1/2 GRD A325	2
2	99.E0095	.LOCKNUT, 5/8-11 HEAVY NYLON	2
3	64.1791	.BRACKET, WIRE/CABLE RETAINER	1
4	05.0060	.GROMMET, 1-1/8 ID, 1-3/4 OD	1
5	64.1753	.PIVOT, CENTER MAIN	1
6	95.08	.WASHER, FLAT 1/2 SAE	4
7	91.0812	.BOLT, 1/2-20 SAE X 1-1/2	4
8	99.E0103	.NUT, LOCKING FLANGE 1/2-13	4
9	62.1409	.FRAME, CONNECTOR ANCHOR	1
10	29.GF0001	.GREASE FTG, 1/4 SAE ST	3
11	42.0566	.LINK, FRONT/REAR CONNECTOR	1
12	64.1792	.BUSHING, CENTER PIVOT BOLT	1
13	99.E0115	.NUT, JAM 3/4-10 NYLON LOCK WID	1
14	97.1226	.BOLT, CARRIAGE 3/4-10 X 3-1/4	1
15	44.0340	.SLEEVE, 2X15 PROTECTOR BUNDLIN	1

FRAMES / SHEET METAL

ILLUSTRATED DRAWING Front Frame & Step

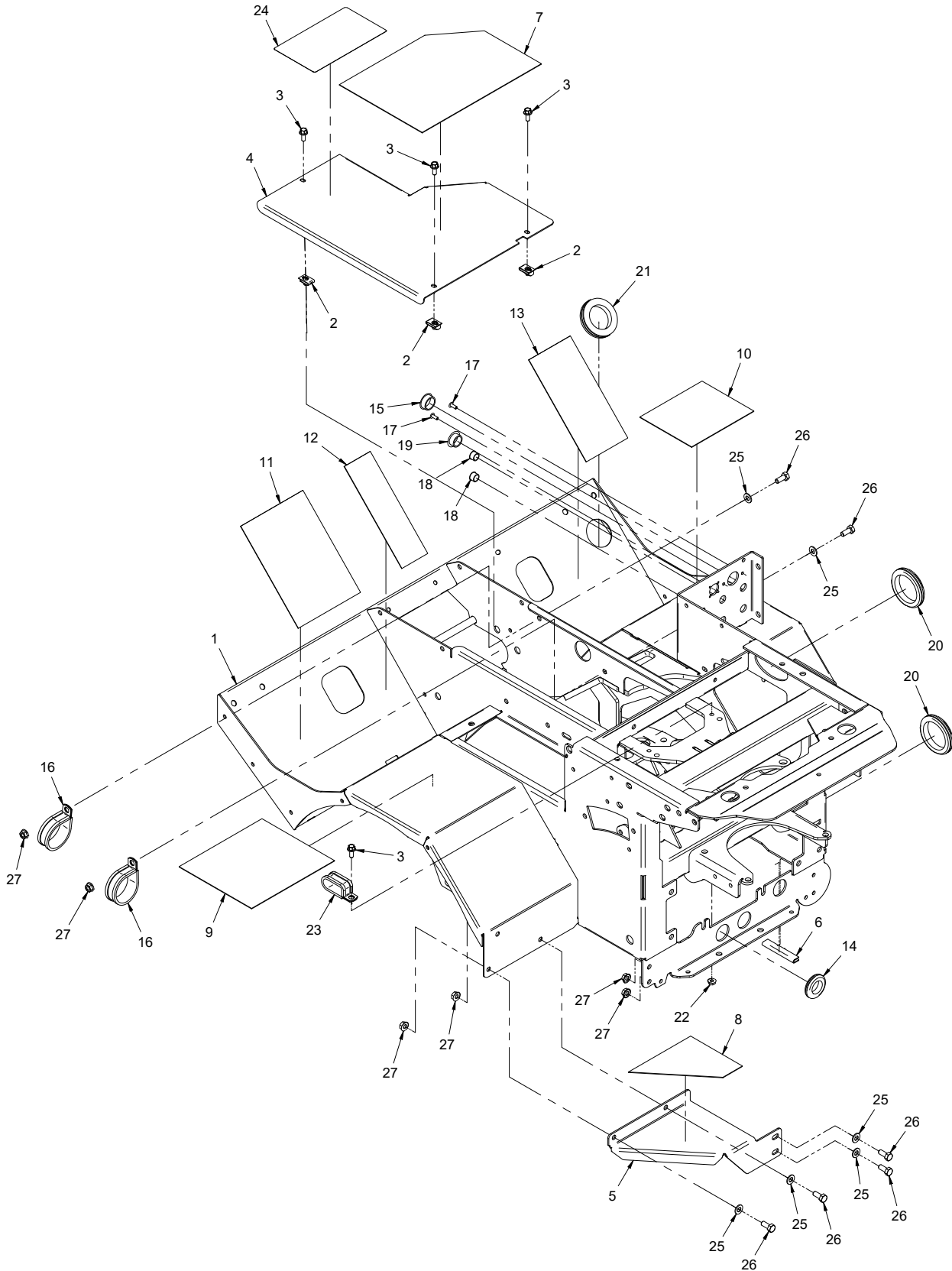

FRAMES / SHEET METAL

Front Frame & Step

REF.	PART NO.	DESCRIPTION	QTY.
1	62.1403	.FRAME, FRONT 3400	1
2	99.E0046	.NUT, "U" 1/4-20 EXTRUDED	3
3	99.SF0405-1	.BOLT, SMF 1/4-20 X 5/8	4
4	60.1198	.COVER, TUNNEL ACCESS	1
5	64.1275	.BRACKET, FOOT STEP LEFT	1
6	06.0050-3IN	.TRIM, TRIM LOC 1/2 X 3/16 X 3"	1
7	44.0346	.FLEX TREAD, TUNNEL	1
8	44.0233	.FLEX TREAD, FOOT STEP	1
9	44.0237	.FLEX TREAD, LEFT FENDER	1
10	44.0232	.FLEX TREAD, RIGHT FENDER	1
11	44.0236	.FLEX TREAD, LEFT FOOT PLATE	1
12	44.0235	.FLEX TREAD, LEFT FOOT PLATE	1
13	44.0234	.FLEX TREAD, RIGHT FOOT PLATE	1
14	05.0044	.GROMMET, 1 ID, 1-3/4OD, 3/8THK	1
15	05.0109	.PLUG, 1" HOLE, BLK PLASTIC	1
16	11.0065	.CLAMP, CUSHIONED METAL 2"	2
17	05.0155	.PLUG, 3/16" HOLE, BLK PLASTIC	2
18	05.0153	.PLUG, 9/16" HOLE, BLK PLASTIC	2
19	05.0152	.PLUG, 7/8" HOLE, BLK PLASTIC	1
20	05.0056	.GROMMET, 2-1/8ID, 2-7/8OD, 7/16T	2
21	05.0071	.GROMMET, 1-3/4ID, 2-3/4OD, 7/16T	1
22	99.SF04	.NUT, SRF 1/4-20 USS	1
23	11.0071	.CLAMP, CUSHIONED METAL 3/4"	1
24	00.0362	.DECAL, WARNING OPERATOR SAFETY	1
25	95.05	.WASHER, FLAT 5/16 SAE	6
26	90.0506	.BOLT, 5/16-18 USS X 3/4"	6
27	99.SF05	.NUT, SRF 5/16-18 USS	6

FRAMES / SHEET METAL

ILLUSTRATED DRAWING Steering Column

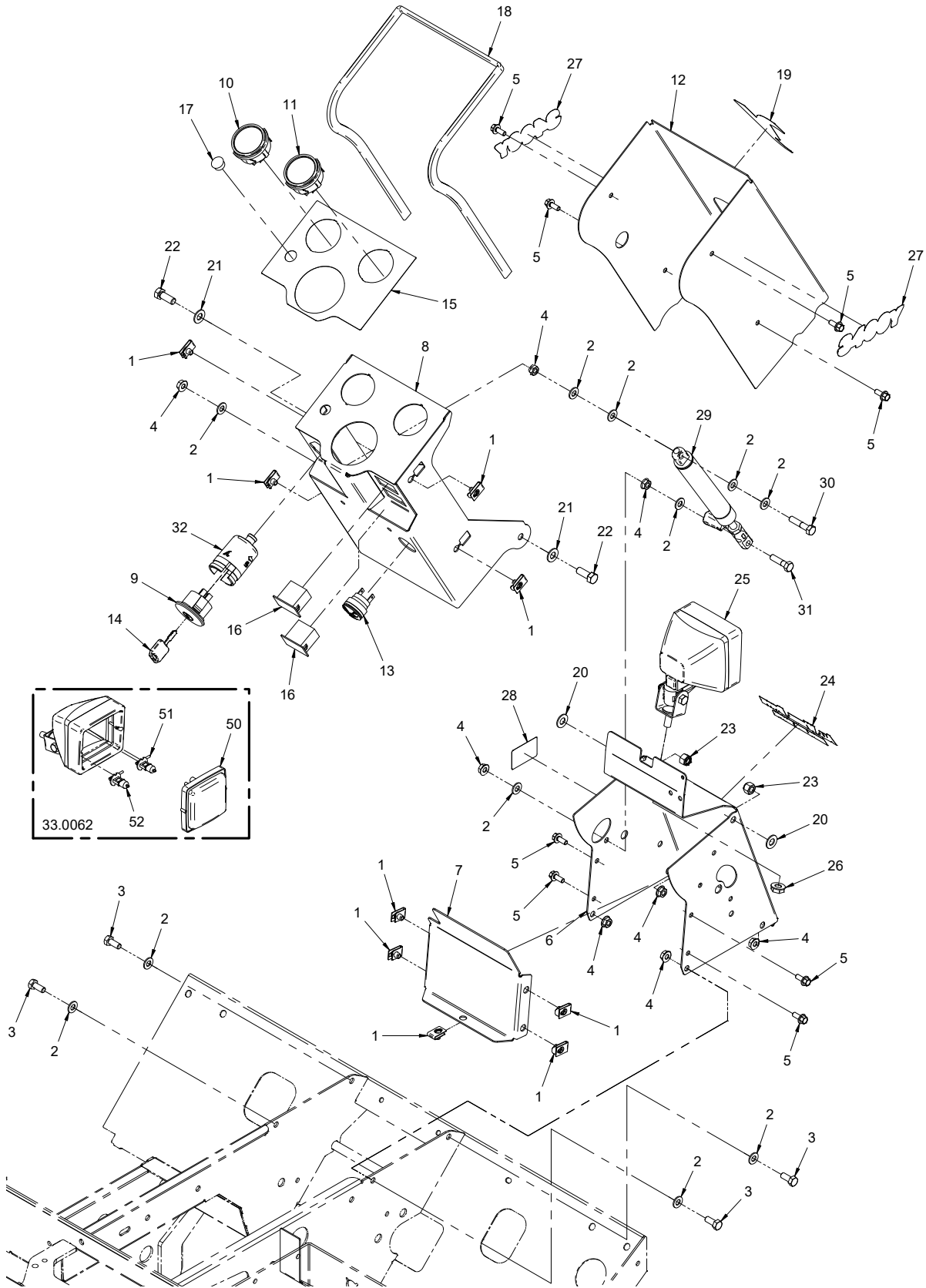

FRAMES / SHEET METAL

Steering Column

REF.	PART NO.	DESCRIPTION	QTY.
1	99.E0046	.NUT, "U" 1/4-20 EXTRUDED	9
2	95.05	.WASHER, FLAT 5/16 SAE	11
3	90.0506	.BOLT, 5/16-18 USS X 3/4"	4
4	99.SF05	.NUT, SRF 5/16-18 USS	8
5	99.SF0405-1	.BOLT, SMF 1/4-20 X 5/8	8
6	62.1408	.COLUMN, 3400 STEERING BASE	1
7	60.0970	.COVER, STEERING COLUMN BASE	1
8	62.1404	.COLUMN, 3400 STEERING	1
9	13.0078	.SWITCH, IGNITION DELTA	1
10	35.0133	.GAUGE, CLUSTER RPM/HOUR	1
11	35.0132	.GAUGE, CLUSTER FUEL	1
12	60.1185	.COVER, STEERING COLUMN	1
13	35.0124	.ALARM, AUDIBLE CONT. PANEL MT.	1
14	13.0080	.KEY, IGNITION DELTA	1
15	00.0351	.DECAL, STEERING COLUMN	1
16	05.0131	.PLUG, SWITCH OTTO K5	2
17	05.0139	.PLUG, 5/8" HOLE, BLK PLASTIC	1
18	06.0042-45.25IN	.TRIM, TRIM LOC 1/2 X 1/16 X 45-1/4"	1
19	00.0192	.DECAL, V-DECAL DIE CUT BLUE	1
20	05.0083	.WASHER, PVC .375ID X .875 X .0625	2
21	95.06	.WASHER, FLAT 3/8 SAE	2
22	90.0608	.BOLT, 3/8-16 USS X 1	2
23	99.A06N	.LOCKNUT, NYLON 3/8-16 USS	2
24	00.0384	.DECAL, ALL WHEEL DRIVE	1
25	33.0062	.LIGHT, WORK 3 X 3	1
26	99.M0021	.NUT, SMF M10 X 1.5	1
27	00.0358	.DECAL, 3400Y	2
28	00.0377	.DECAL, STEERING COLUMN TILT	1
29	47.0250	.SHOCK, GAS BLOC-O-LIFT LOCKING	1
30	90.0512	.BOLT, 5/16-18 USS X 1-1/2"	1
31	90.0510	.BOLT, 5/16-18 USS X 1-1/4"	1
32	30.0469	.COVER, SPLASHGUARD IG SWITCH (Serial # 01606-)	1
50	33.0054	.OPTICAL UNIT, LENS/REFLECTOR	1
51	33.0055	.BULB, LIGHT (ONLY) FOR 55 WATT	1
52	33.0056	.BULB, LIGHT (ONLY) FOR 35 WATT (Optional)	1

FRAMES / SHEET METAL

ILLUSTRATED DRAWING Right Dash Panel & SDLA Cover

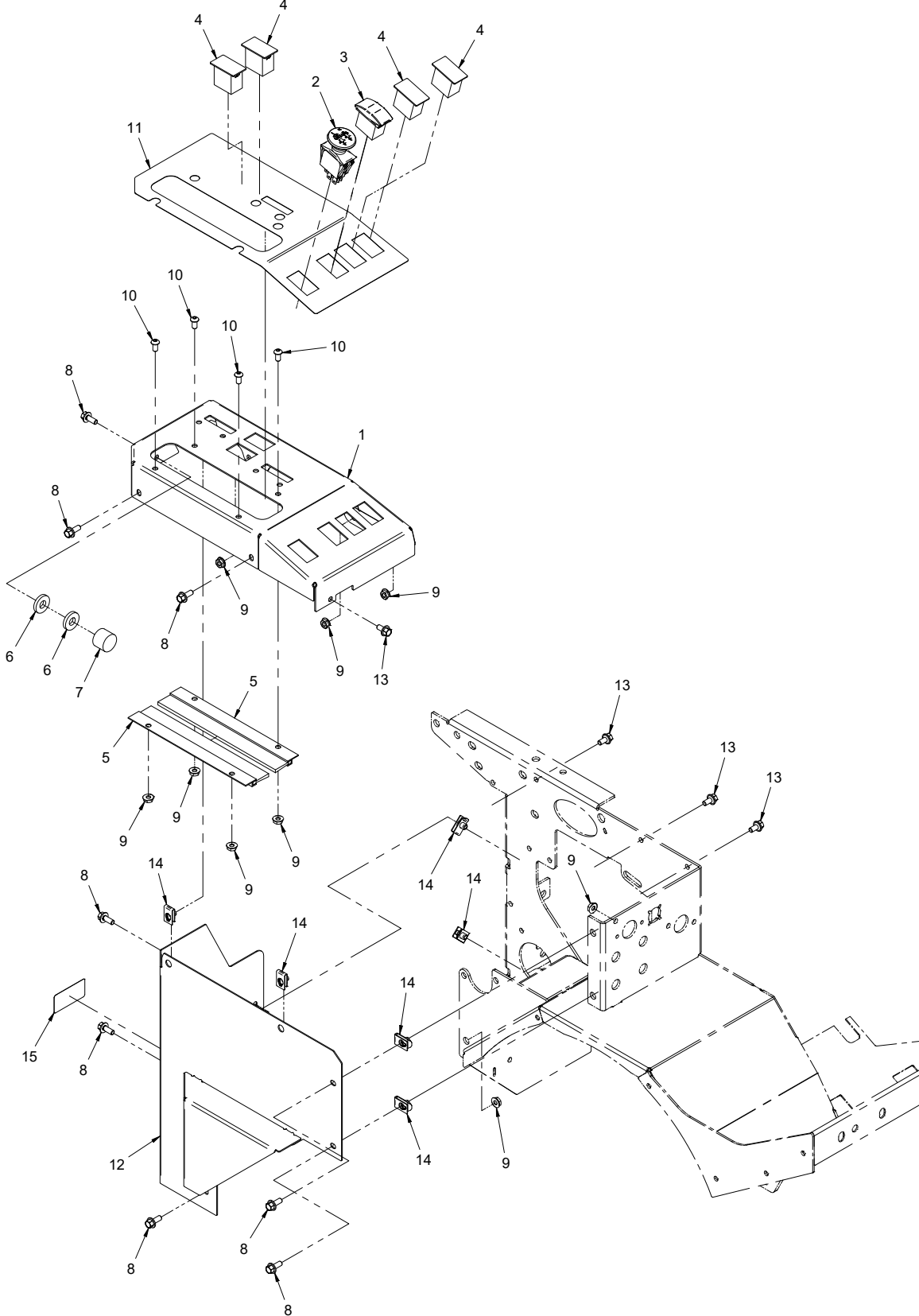

FRAMES / SHEET METAL

Right Dash Panel & SDLA Cover

REF.	PART NO.	DESCRIPTION	QTY.
1	60.1186	.PANEL, DASH RIGHT	1
2	31.0043	.SWITCH, PTO - PUSH / PULL	1
3	31.0053	.SWITCH, ROCKER ON/OFF	1
4	05.0131	.PLUG, SWITCH OTTO K5	4
5	79.0098	.BRUSH, SDLA COVER W/HOLDER	2
6	99.G0014	.WASHER, 3/8 USS FW .165 THK	2
7	05.0125	.BUMPER, NEOPRENE 1" DIA	1
8	99.SF0405-1	.BOLT, SMF 1/4-20 X 5/8	8
9	99.SF04	.NUT, SRF 1/4-20 USS	9
10	99.0404	.BOLT, 1/4-20 X 1/2 BSCS	4
11	00.0352	.DECAL, DASH SIDE	1
12	60.1187	.COVER, SDLA ACCESS	1
13	99.SF0404-1	.BOLT, SMF 1/4-20 X 1/2	4
14	99.E0046	.NUT, "U" 1/4-20 EXTRUDED	6
15	00.0376	.DECAL, NEUTRAL	1

FRAMES / SHEET METAL

ILLUSTRATED DRAWING Front Hitch

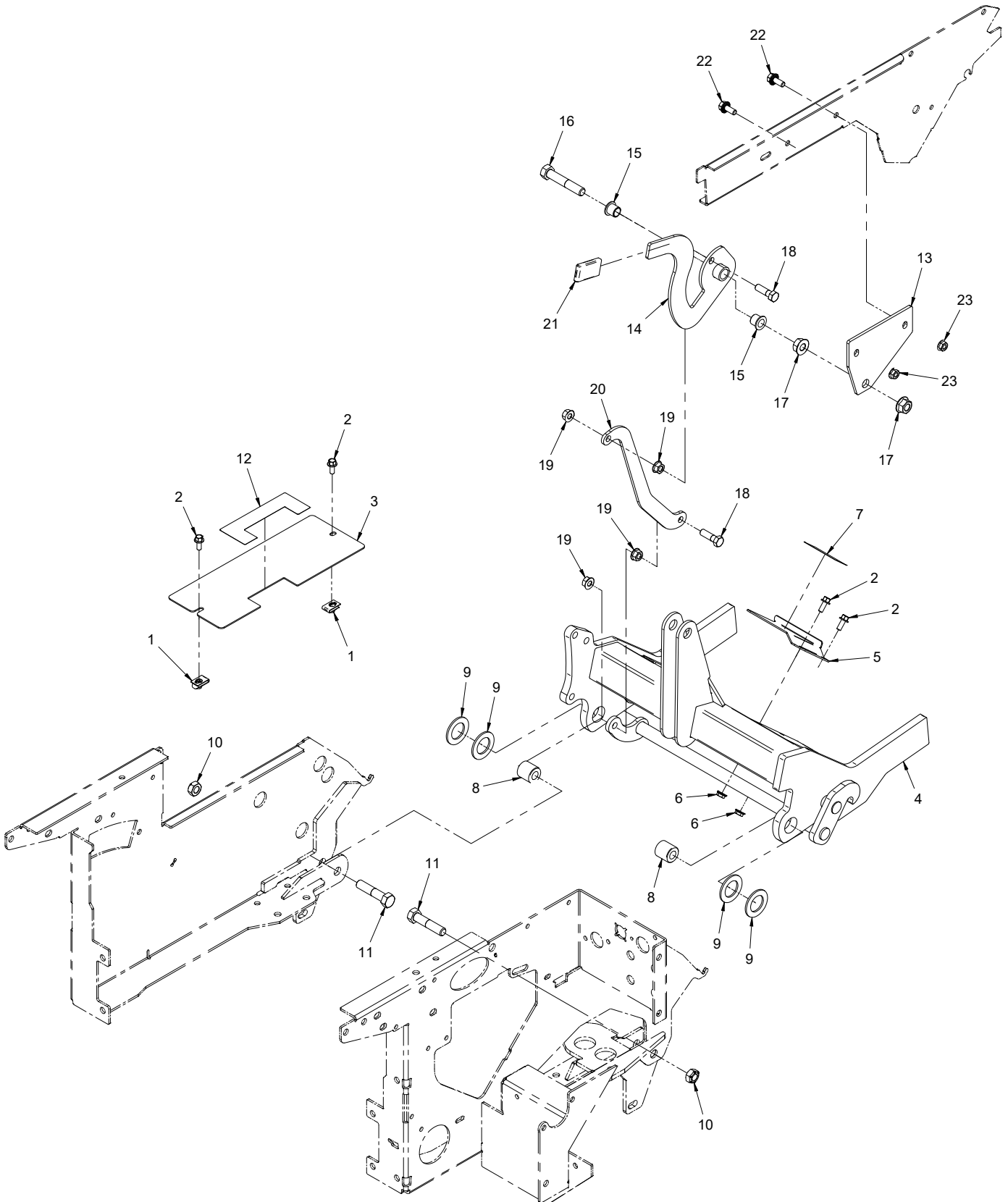

FRAMES / SHEET METAL

Front Hitch

REF.	PART NO.	DESCRIPTION	QTY.
1	99.E0046	.NUT, "U" 1/4-20 EXTRUDED	2
2	99.SF0405-1	.BOLT, SMF 1/4-20 X 5/8	4
3	60.0969	.COVER, WEIGHT TRANSFER ACCESS	1
4	62.1259	.FRAME, FRONT HITCH	1
5	60.0973	.SHIELD, FRONT DOUBLE IDLER BELT	1
6	99.SF04	.NUT, SRF 1/4-20 USS	2
7	00.0365	.DECAL, WARNING MOVING PARTS	1
8	64.0807	.BUSHING, .516X 1.00X 1.00	2
9	99.B0093	.WASHER, 1.064 X 1.75 X .103T	4
10	99.A08	.LOCKNUT, STOVER 1/2-13 USS	2
11	90.0818	.BOLT, 1/2-13 USS X 2-1/4	2
12	00.0379	.DECAL, FRONT HITCH LOCK	1
13	64.1300	.BRACKET, FRONT HITCH LEVER POV	1
14	40.0340	.LEVER, FRONT HITCH LATCH	1
15	85.B0027	.BUSHING, 1/2 ID X 5/8 OD X 5/8	2
16	90.0822	.BOLT, 1/2-13 USS X 2-3/4	1
17	99.SF08	.NUT, SF 1/2-13 USS	2
18	90.0610	.BOLT, 3/8-16 USS X 1-1/4	2
19	99.SF06	.NUT, SF 3/8-16 USS	4
20	42.0512	.LINK, FRONT HITCH LATCH	1
21	06.0051	.CAP, 3/16 X 15/16 X 1-3/4 FE	1
22	99.SF0506	.BOLT, SRF 5/16-18 USS X 3/4	2
23	99.SF05	.NUT, SRF 5/16-18 USS	2

FRAMES / SHEET METAL

ILLUSTRATED DRAWING Weight Transfer

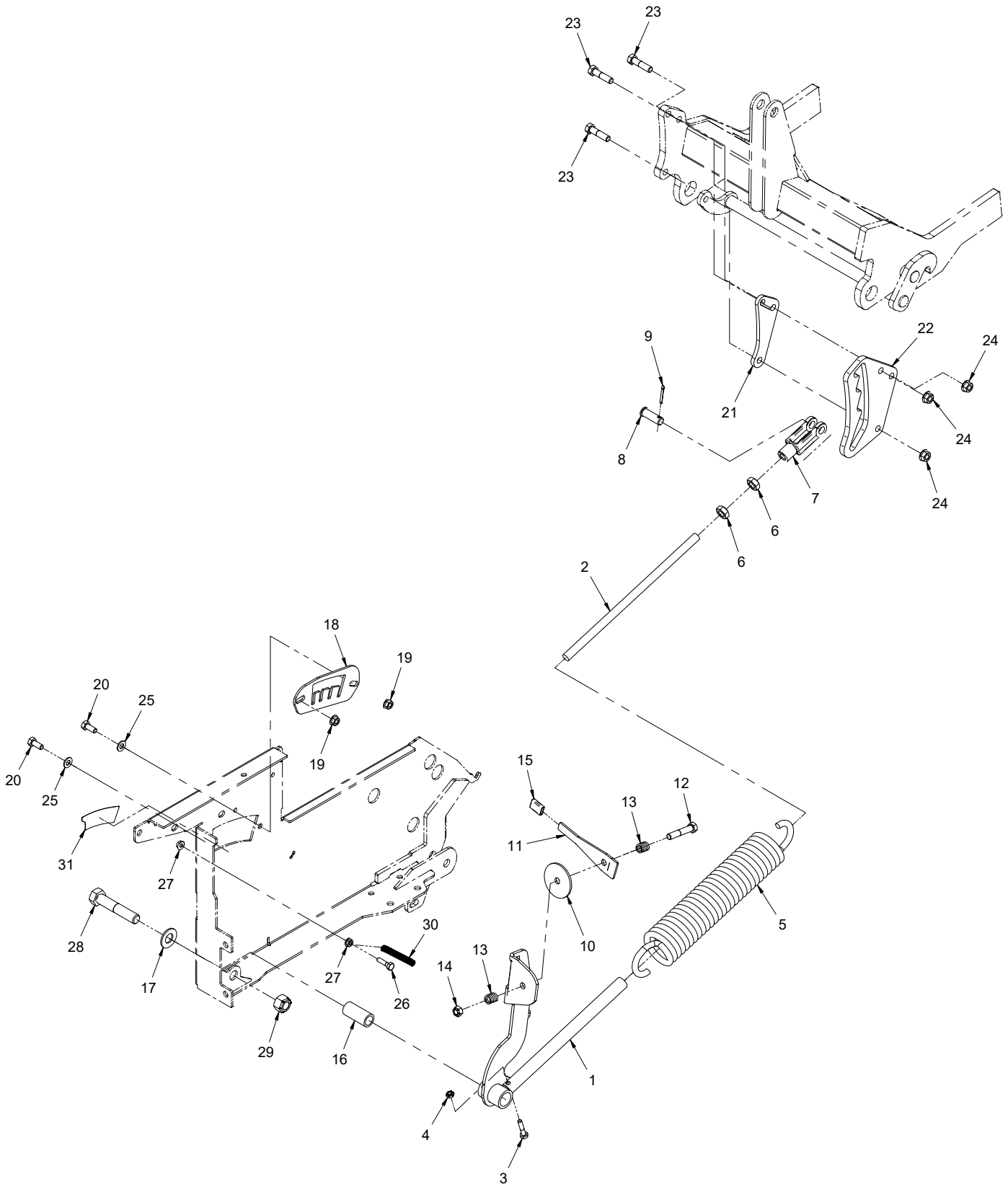

FRAMES / SHEET METAL

Weight Transfer

REF.	PART NO.	DESCRIPTION	QTY.
1	40.0341	.ARM, WEIGHT TRANSFER.	1
2	42.0517	.ROD, THREAD 1/2-20 X 12" LH/RH.	1
3	90.0410	.BOLT, 1/4-20 USS X 1/1-4"	1
4	99.A04	.LOCKNUT, STOVER 1/4-20 USS	1
5	41.0080	.SPRING, WEIGHT TRANSFER.	1
6	99.E0079	.NUT, JAM 1/2-20 RH ZP	2
7	43.C08-1R	.CLEVIS END, 1/2-20 RH THREAD, YOKE	1
8	03.0812	.CLEVIS PIN, 1/2 X 1-1/2.	1
9	02.CP0408	.COTTER PIN, 1/8 X 1.	1
10	05.0002	.WASHER, FRIC. 2-1/4 X 13/32.	1
11	40.0343	.LEVER, WEIGHT TRANSFER.	1
12	90.0616	.BOLT, 3/8-16 USS X 2.	1
13	41.0039	.SPRING, COMP. 9/16 OD X 5/8.	2
14	99.A06N	.LOCKNUT, NYLON 3/8-16	1
15	06.0044	.CAP, PLASTIC 1/8 X 1/2 X 7/8	1
16	64.1269	.BUSHING, .635X 7/8X 1-7/8L	1
17	95.10	.WASHER, FLAT 5/8 SAE	1
18	60.0972	.PLATE, WEIGHT TRANSFER INDEX	1
19	99.SF05	.NUT, SRF 5/16-18 USS.	2
20	90.0506	.BOLT, 5/16-18 USS X 3/4"	2
21	64.1272	.SPACER, HITCH/WEIGHT TRANSFER	1
22	64.1271	.PLATE, WT TRANSFER INDEX	1
23	90.0612	.BOLT, 3/8-16 USS X 1-1/2.	3
24	99.SF06	.NUT, SRF 3/8-16 USS.	3
25	95.05	.WASHER, FLAT 5/16 SAE	2
26	90.0406	.BOLT, 1/4-20 USS X 3/4"	1
27	99.SF04	.NUT, SRF 1/4-20 USS.	2
28	90.1026	.BOLT, 5/8-11 USS X 3-1/4.	1
29	99.A10	.LOCKNUT, STOVER 5/8-11 USS.	1
30	41.0086	.SPRING, EXT 3/8" OD X 4" LONG	1
31	00.0359	.DECAL, WEIGHT TRANSFER.	1

FRAMES / SHEET METAL

ILLUSTRATED DRAWING Roll Bar

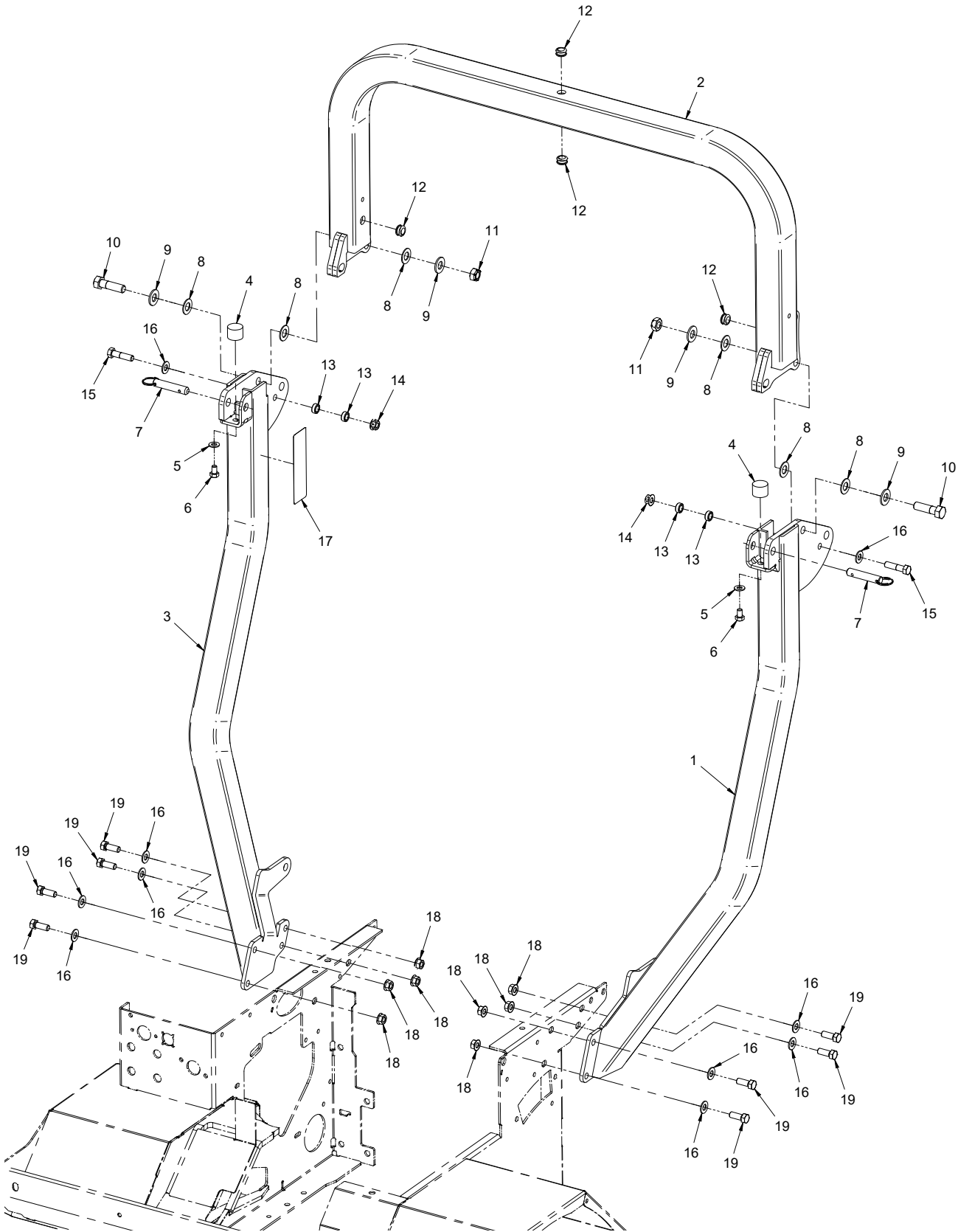

FRAMES / SHEET METAL

Roll Bar

REF.	PART NO.	DESCRIPTION	QTY.
1	62.1407	.ROLLBAR, LEFT	1
2	62.1405	.ROLLBAR, TOP	1
3	62.1406	.ROLLBAR, RIGHT	1
4	05.0110	.BUMPER, RUBBER 1" DIA	2
5	95.05	.WASHER, FLAT 5/16 SAE	2
6	90.0504	.BOLT, 5/16-18 USS X 1/2"	2
7	03.0007	.PIN, BALL 1/2 X 1.8"	2
8	05.0145	.WASHER .55ID X 1.03OD X .062T	6
9	95.08	.WASHER, FLAT 1/2 SAE	4
10	90.0814	.BOLT, 1/2-13 USS X 1-3/4	2
11	99.A08	.LOCKNUT, STOVER 1/2-13 USS	2
12	05.0138	.GROMMET, 7/16ID, 11/16OD, 3/8THK	4
13	64.0602	.BUSHING, 3/8 X 5/8 X .265	4
14	99.E0082	.NUT, LOCKING FLANGE 3/8-16	2
15	90.0612	.BOLT, 3/8-16 USS X 1-1/2	2
16	95.06	.WASHER, FLAT 3/8 SAE	10
17	00.0360	.DECAL, ROPS CERTIFICATION	1
18	99.SF06	.NUT, SRF 3/8-16 USS	8
19	90.0608	.BOLT, 3/8-16 USS X 1	8

FRAMES / SHEET METAL

ILLUSTRATED DRAWING Seat Assembly

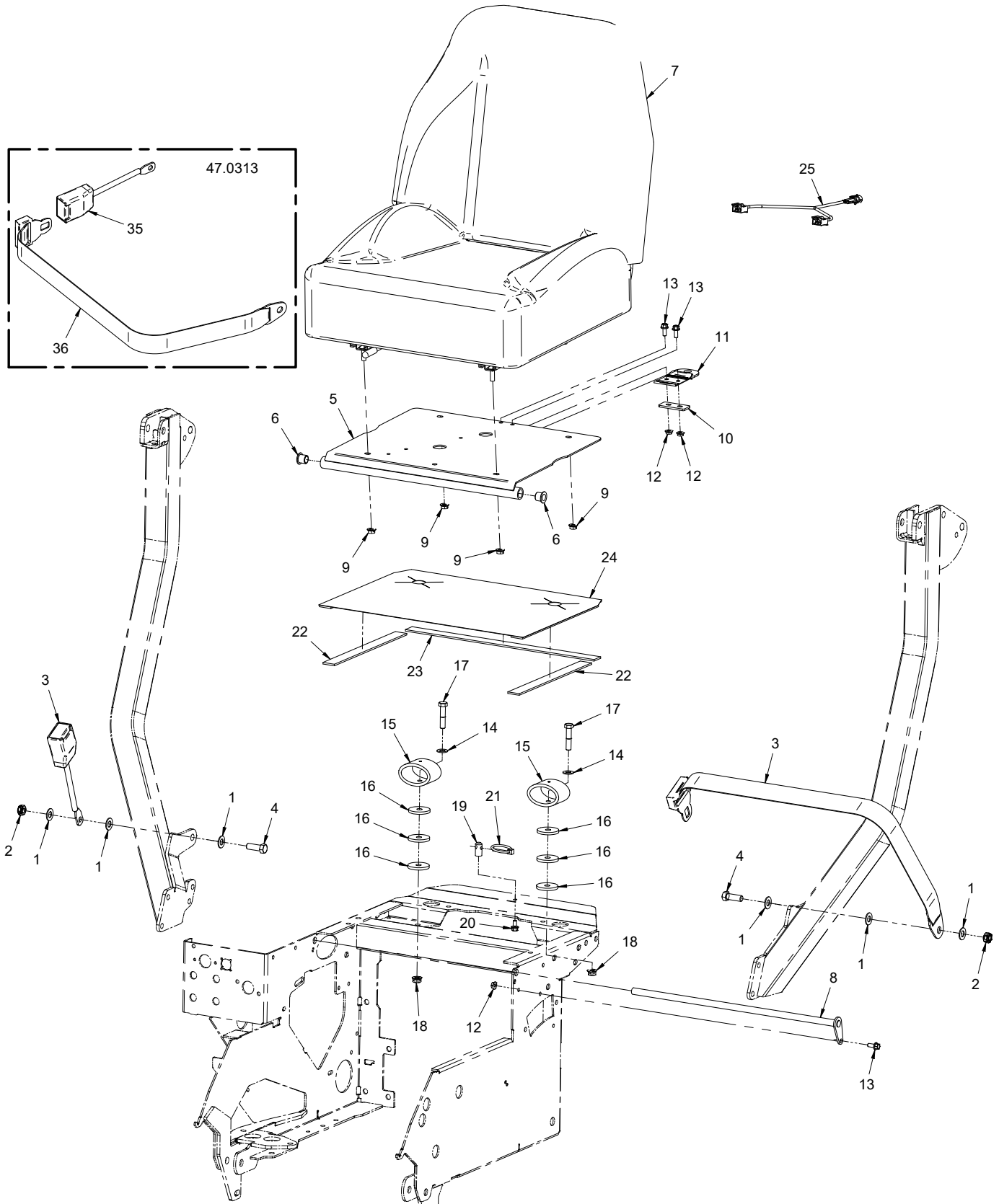

FRAMES / SHEET METAL

Seat Assembly

REF.	PART NO.	DESCRIPTION	QTY.
1	95.07	.WASHER, FLAT 7/16 SAE	6
2	99.A07	.LOCKNUT, STOVER 7/16-14 USS	2
3	47.0313	.SEAT BELT, LAP W/BUCKLE	1
4	90.0710	.BOLT, 7/16-14 USS X 1-1/4	2
5	64.1822	.PLATE, SEAT	1
6	85.B0027	.BUSHING, 1/2 ID X 5/8 OD X 5/8	2
7	47.0360	.SEAT, DELUXE W/MANUAL HOLDER	1
	31.0060	.SWITCH, SEAT	2
	47.0366	.COVER, SEAT BOTTOM	1
	47.0367	.COVER, SEAT BACK	1
8	64.1259	.ROD, CR 1/2 X 18 SEAT PIVOT	1
9	99.SF05	.NUT, SRF 5/16-18 USS	4
10	64.1723	.CLAMP, SEAT LATCH STRAP	1
11	47.0335	.STRAP, SEAT LATCH	1
12	99.SF04	.NUT, SRF 1/4-20 USS	3
13	99.SF0405-1	.BOLT, SMF 1/4-20 X 5/8	3
14	95.06	.WASHER, FLAT 3/8 SAE	2
15	05.0137	.BUMPER, ELASTOMER 3.4"	2
16	99.B0076	.WASHER, .185 X 13/32 ID X 1-5/8	6
17	90.0614	.BOLT, 3/8-16 USS X 1-3/4	2
18	99.E0082	.NUT, LOCKING FLANGE 3/8-16	2
19	03.0019	.PIN, SEAT LATCH	1
20	99.SF0404-1	.BOLT, SMF 1/4-20 X 1/2	1
21	03.0021	.PIN, LYNCH 3/16	1
22	06.0065-11IN	.VELCRO, LOOP 1" BLACK X 11"	2
23	06.0065-16.5IN	.VELCRO, LOOP 1" BLACK X 16-1/2"	1
24	44.0334	.CANVAS, FRONT FRAME	1
25	32.0143	.HARNESS, 3400/4500 SEAT	1
35	47.0313-2	.SEAT BELT, BUCKLE	1
36	47.0313-1	.SEAT BELT, LAP BELT	1

CONTROLS & LINKAGE

ILLUSTRATED DRAWING SDLA Control Levers

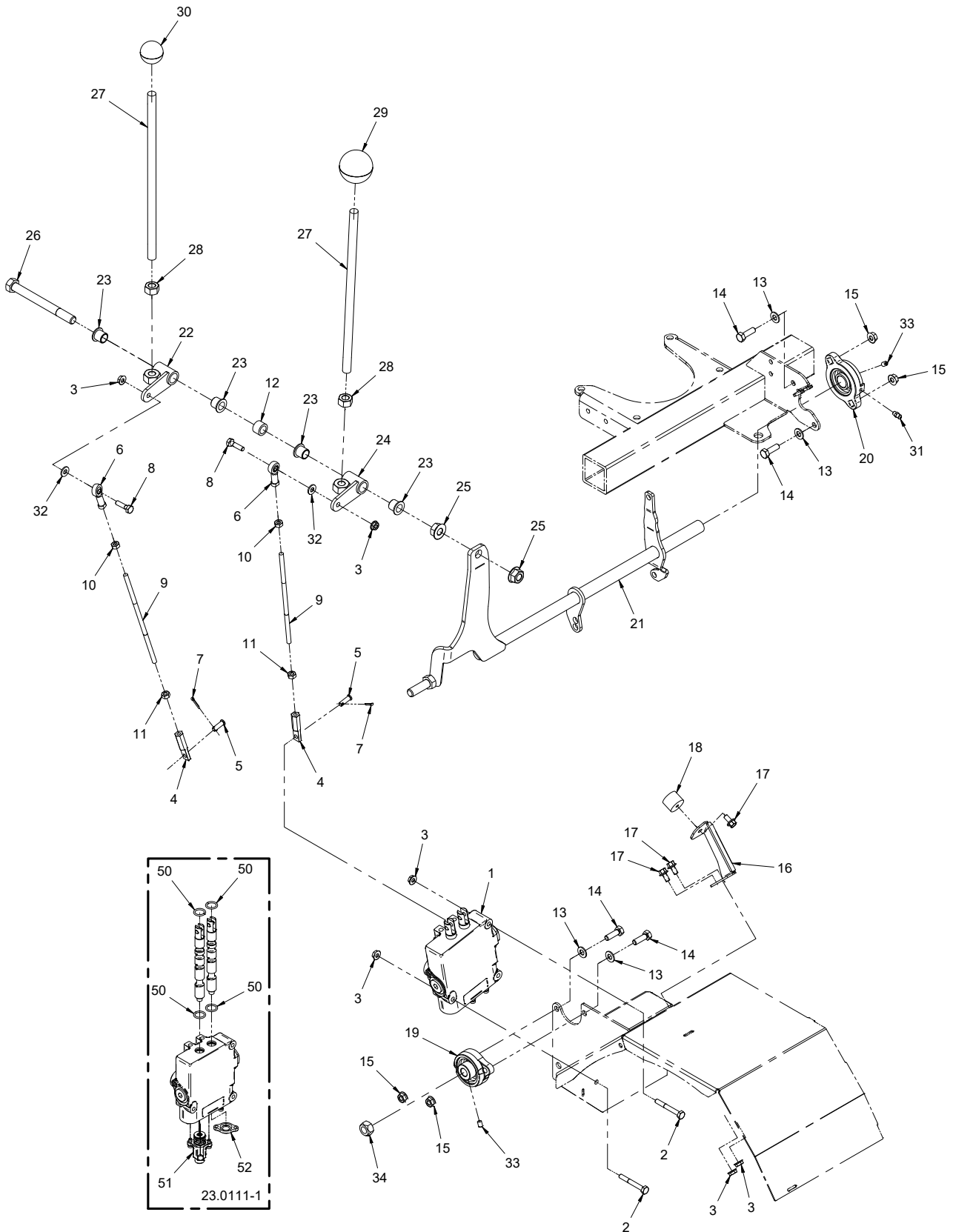

CONTROLS & LINKAGE

SDLA Control Levers

REF.	PART NO.	DESCRIPTION	QTY.
1	23.0111-1	.VALVE, HY 2 SPL W/LH FLT, RH SP.	1
2	90.0416	.BOLT, 1/4-20 USS X 2"	2
3	99.SF04	.NUT, SRF 1/4-20 USS.	6
4	43.004-4	.ROD END, 1/4-28LH YZP VAL CTRL	2
5	03.0406	.CLEVIS PIN, 1/4 X 3/4	2
6	43.004	.ROD END, 1/4 SPHERICAL	2
7	02.CP0306	.COTTER PIN, 3/32 X 3/4	2
8	90.0408	.BOLT, 1/4-20 USS X 1"	2
9	42.0515	.ROD, THREAD 1/4-28 X 7" RH/LH.	2
10	93.04	.NUT, 1/4-28 SAE	2
11	99.E0081	.NUT, 1/4-28 LH GRADE 8 YZ.	2
12	64.1783	.BUSHING, 1/2ID X 3/4OD X 1/2L	1
13	95.05	.WASHER, FLAT 5/16 SAE	4
14	90.0508	.BOLT, 5/16-18 USS X 1"	4
15	99.SF05	.NUT, SRF 5/16-18 USS.	4
16	64.1779	.BRACKET, SDLA FRONT STOP	1
17	99.SF0404-1	.BOLT, SMF 1/4-20 X 1/2	3
18	05.0125	.BUMPER, NEOPRENE 1" DIA.	1
19	55.FB16008	.BEARING, FLANGE BLCK 1/2 ID	1
20	55.FB16012-1	.BEARING, FLANGE BLOCK 3/4"	1
21	42.0565	.LINKAGE, FORWARD/REVERSE	1
22	42.0503	.PIVOT, SDLA LIFT CONTROL	1
23	85.B0027	.BUSHING, 1/2 ID X 5/8 OD X 5/8	4
24	42.0572	.PIVOT,SDLA LIFT CONTROL	1
25	99.SF08	.NUT, SRF 1/2-13 USS.	2
26	90.0840	.BOLT, 1/2-13 USS X 5.	1
27	40.0240	.HANDLE, F/R CONTROL	2
28	92.08	.NUT, 1/2-13 USS	2
29	47.0003	.KNOB, ROUND 2" X 1/2-13 THREAD	1
30	47.0329	.KNOB, ROUND 1-3/8 X 1/2-13.	1
31	29.GF0001	.GREASE FTG, 1/4 SAE ST	1
32	95.04	.WASHER, FLAT 1/4 SAE	2
33	85.SS11	.SET SCREW, 1/4-28 X 3/8".	2
34	99.A08NF	.LOCKNUT, STOVER 1/2-20 SAE.	1
50	26.0027	.O-RING, 5/8ID X 13/16OD X 3/32	4
51	23.0111-7	.KIT, SPOOL FLOAT HYD. VALVE	1
52	23.0111-8	.CAP, VALVE.	1

CONTROLS & LINKAGE

ILLUSTRATED DRAWING SDLA Linkage

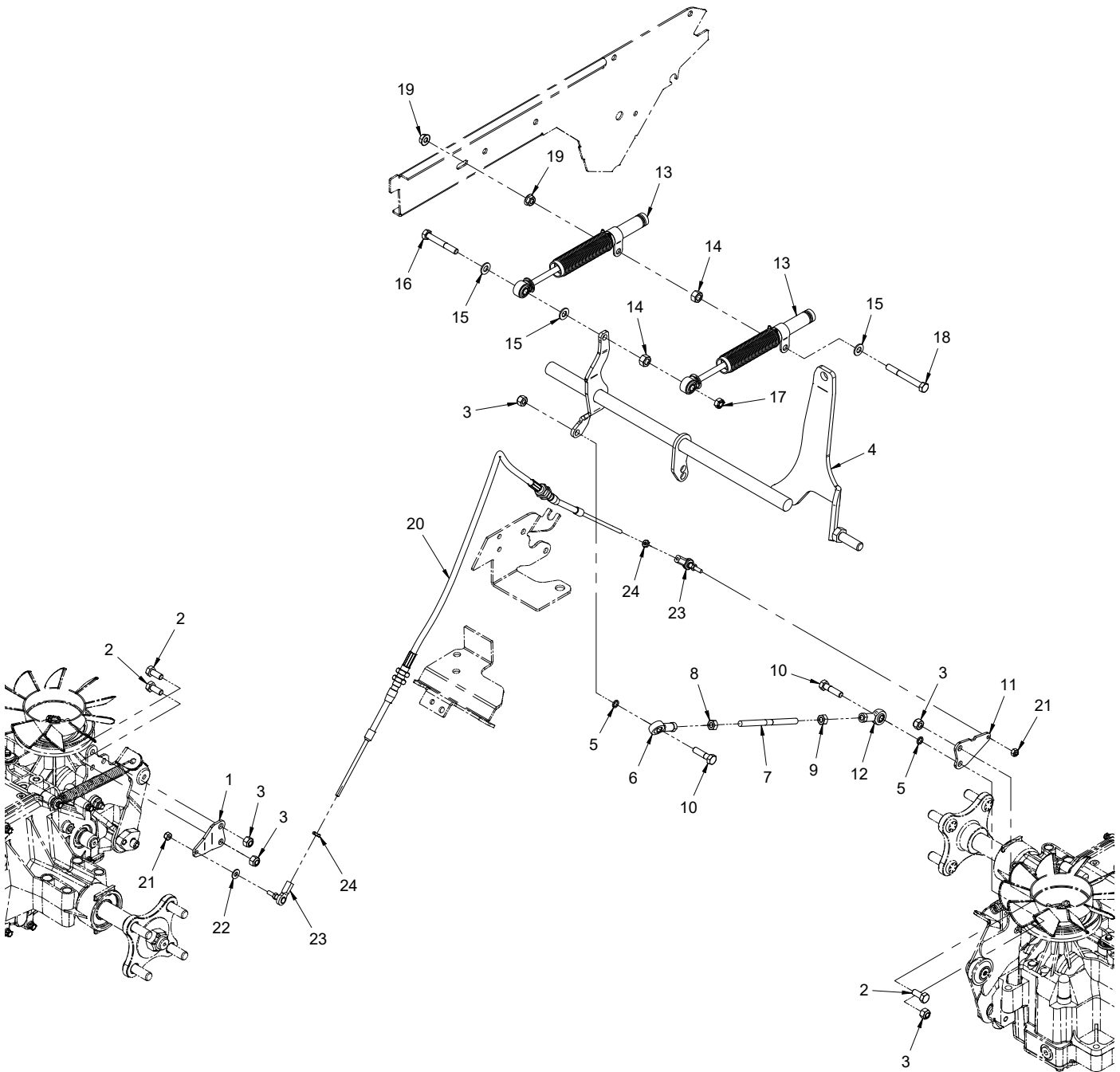

CONTROLS & LINKAGE

SDLA Linkage

REF.	PART NO.	DESCRIPTION	QTY.
1	60.0971	.PLATE, REAR AXLE CABLE MOUNT	1
2	91.0506	.BOLT, 5/16-24 SAE X 3/4	3
3	99.A05NFN	.LOCKNUT, NYLON 5/16-24 SAE ZP	5
4	42.0565	.LINKAGE, FORWARD/REVERSE	1
5	99.B0102	.WASHER, .313ID X .438OD X .062	2
6	43.005L	.ROD END, 5/16 SPHERICAL (LH)	1
7	42.0518	.ROD, THREAD 5/16-24 X 4.5" LH/RH	1
8	99.E0084	.NUT, 5/16-24 LEFT HAND ZP	1
9	93.05	.NUT, 5/16-24 SAE	1
10	91.0510	.BOLT, 5/16-24 SAE X 1-1/4	2
11	64.1536	.PLATE, FRONT AXLE CABLE MOUNT	1
12	43.005	.ROD END, 5/16 SPHERICAL	1
13	47.0242	.DAMPER, 2.625 STROKE GAS SHOCK	2
14	93.06	.NUT, 3/8-24 SAE	2
15	95.05	.WASHER, FLAT 5/16 SAE	3
16	90.0518	.BOLT, 5/16-18 USS X 2-1/4"	1
17	99.A05	.LOCKNUT, STOVER 5/16-18 USS	1
18	90.0522	.BOLT, 5/16-18 USS X 2-3/4	1
19	99.SF05	.NUT, SRF 5/16-18 USS	2
20	47.0353	.CABLE, CONTROL PUSH-PULL	1
21	99.A1032N	.LOCKNUT, NYLON 10-32 STAINLESS	2
22	99.B0051	.WASHER, FLAT #10	1
23	43.10-32S	.ROD END, 10-32 SPHERICAL W/STUD	2
24	99.E0034	.NUT, #10-32	2

CONTROLS & LINKAGE

ILLUSTRATED DRAWING Foot Pedal

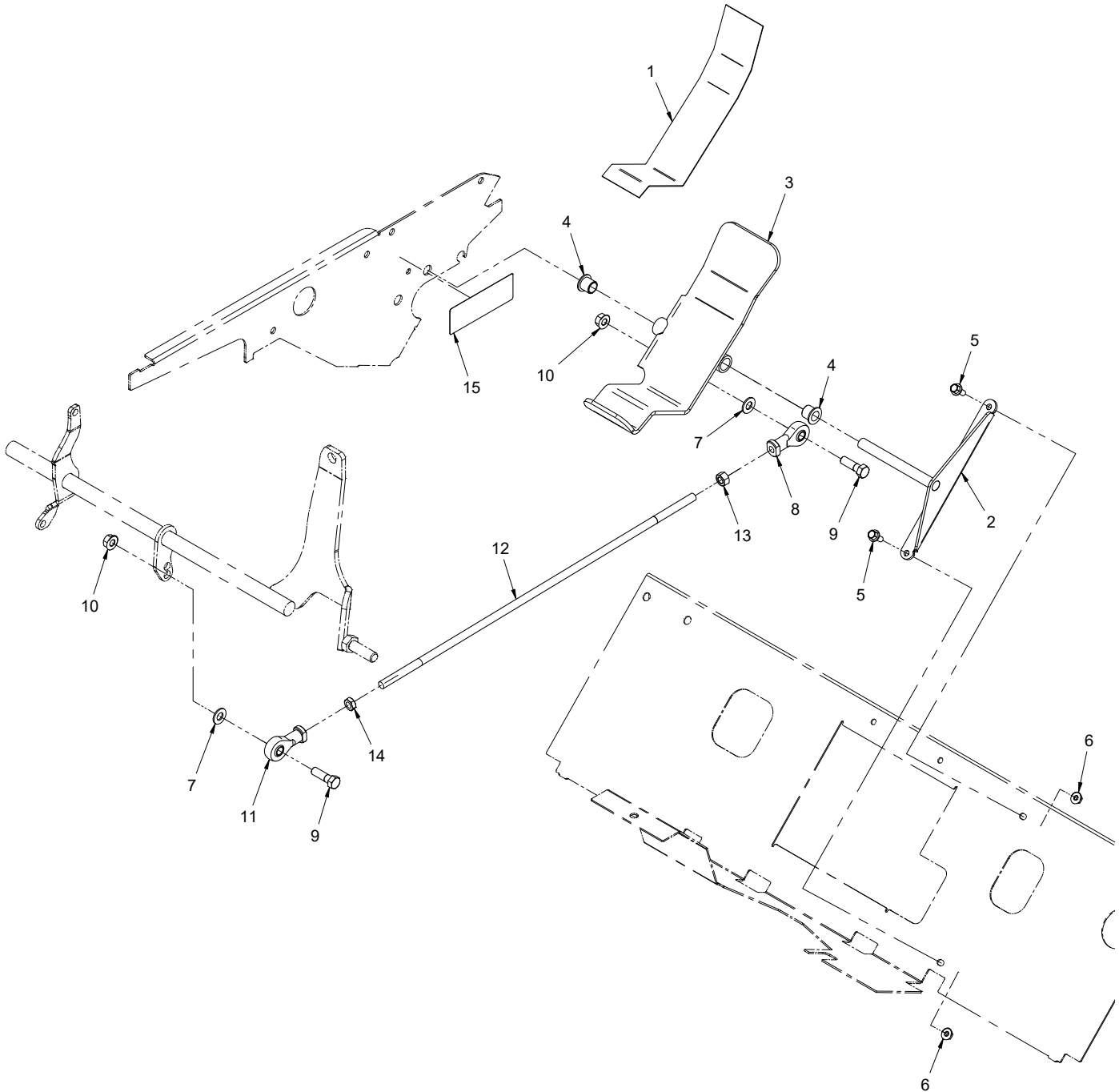

CONTROLS & LINKAGE

Foot Pedal

REF.	PART NO.	DESCRIPTION	QTY.
1	44.0275	.FLEX TREAD, FOOT PEDAL	1
2	42.0506	.PIVOT, FOOT PEDAL	1
3	62.1260	.PEDAL, FOOT	1
4	85.B0027	.BUSHING, 1/2 ID X 5/8 OD X 5/8	2
5	99.SF0405-1	.BOLT, SMF 1/4-20 X 5/8	2
6	99.SF04	.NUT, SRF 1/4-20 USS	2
7	95.06	.WASHER, FLAT 3/8 SAE	2
8	43.006	.ROD END, 3/8 SPHERICAL, FEMALE	1
9	90.0610	.BOLT, 3/8-16 USS X 1-1/4	2
10	99.SF06	.NUT, SRF 3/8-16 USS	2
11	43.006L	.ROD END, 3/8 SPHERICAL, LH THRD	1
12	42.0516	.ROD, THREAD 3/8-24X20.25 RH/LH	1
13	93.06	.NUT, 3/8-24 SAE	1
14	99.E0083	.NUT, JAM 3/8-24 SAE LH ZP	1
15	00.0375	.DECAL, FOOT CONTROL	1

CONTROLS & LINKAGE

ILLUSTRATED DRAWING Parking Brake



CONTROLS & LINKAGE

Parking Brake

REF.	PART NO.	DESCRIPTION	QTY.
1	95.05	.WASHER, FLAT 5/16 SAE	2
2	90.0506	.BOLT, 5/16-18 USS X 3/4"	2
3	99.SF05	.NUT, SRF 5/16-18 USS	3
4	64.1257	.ROCKER, MASTER LOCK OUT PIVOT	1
5	85.B0027	.BUSHING, 1/2 ID X 5/8 OD X 5/8	4
6	64.1260	.PIVOT, CONTROL ANCHOR	2
7	99.SF0405-1	.BOLT, SMF 1/4-20 X 5/8	2
8	99.SF04	.NUT, SRF 1/4-20 USS	10
9	40.0344	.LEVER, PARK/RETURN SELECTOR	1
10	42.0508	.LINK, DRIVE MASTER LOCK OUT	1
11	90.0408	.BOLT, 1/4-20 USS X 1"	4
12	64.0782	.EXTENSION, PUMP CONTROL	1
13	99.SF0506	.BOLT, SRF 5/16-18 USS X 3/4	1
14	64.0781	.EXTENSION, PARK BRAKE LEVER	1
15	99.SF0606	.BOLT, SRF 3/8-16 USS X 3/4	1
16	99.SF06	.NUT, SRF 3/8-16 USS	1
17	42.0502	.LINK, PARK BRAKE	1
18	99.A04NFN	.LOCKNUT, NYLON 1/4-28	1
19	85.SC05	.SET COLLAR, 5/16"	3
20	99.K0073	.BOLT, SHCS 10-32 X 1/2 ZP	3
21	05.0065	.SPACER, 1/4 ID X 1/2 OD X 1 LG	1
22	42.0501	.LINK, NEUTRALIZER CONTROL	1
23	64.1769	.BRACKET, NEUTRAL SWITCH	1
24	31.0044	.SWITCH, PUSH BUTTON - NEUTRAL	1
25	06.0059	.CAP, VINYL 1/2" X 4" LONG	1
26	92.05	.NUT, 5/16-18 USS	1

OPTIONS

ILLUSTRATED DRAWING 70.3044 Work Light Kit

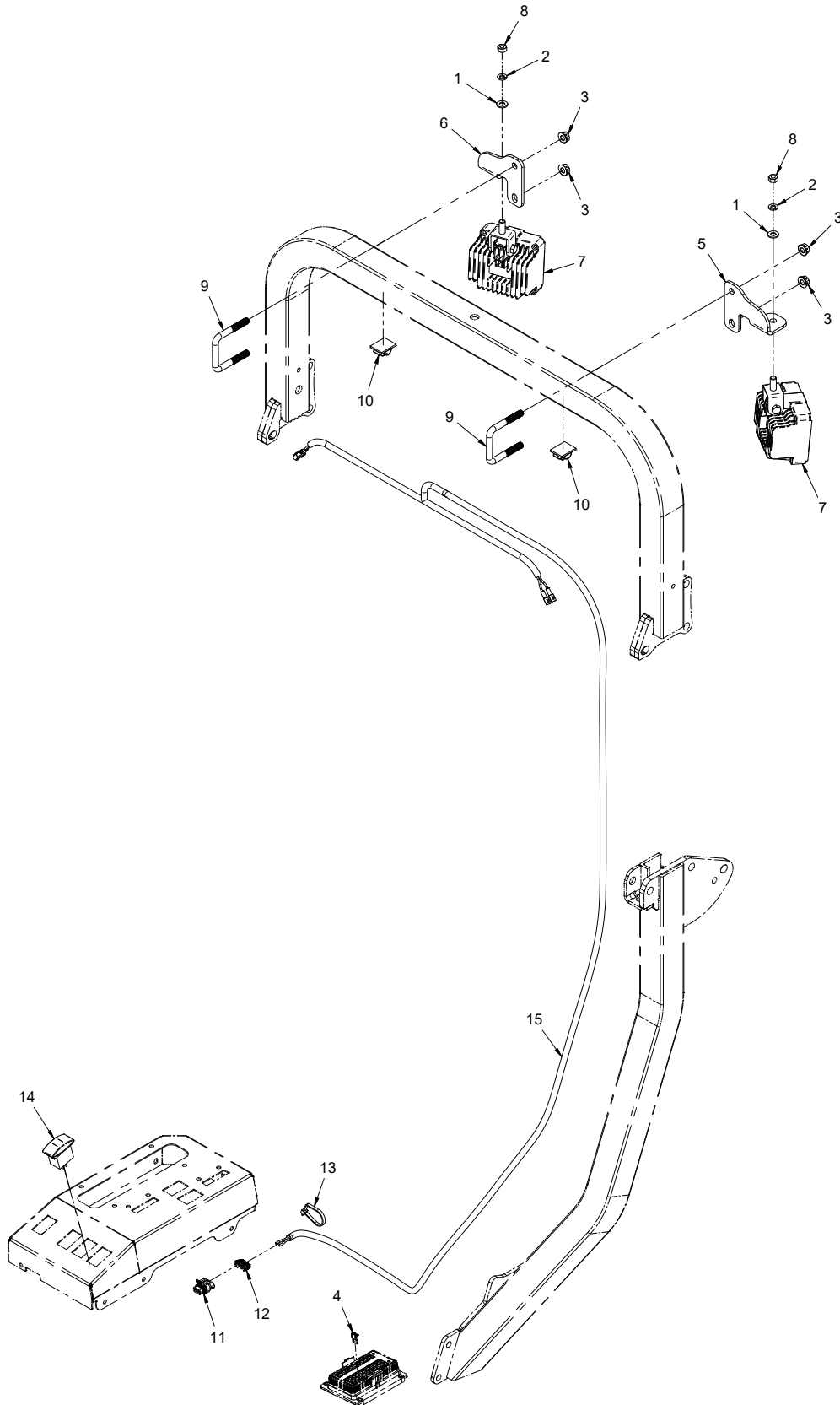

OPTIONS

70.3044 Work Light Kit

REF.	PART NO.	DESCRIPTION	QTY.
1	95.05	.WASHER, FLAT 5/16 SAE	2
2	96.05	.WASHER, LOCK 5/16	2
3	99.E0082	.NUT, LOCKING FLANGE 3/8-16	4
4	30.0334	.FUSE, 15 AMP MINI BLUE	1
5	64.1819	.BRACKET, WORK LIGHT MT LEFT	1
6	64.1824	.BRACKET, WORK LIGHT MT RIGHT	1
7	33.0069	.LIGHT, WORK 3 X 3 LED	2
8	99.M0025	.NUT, M8 X 1.25 ZP	2
9	11.0053	.U-BOLT, 3/8-16 2-1/16" ID SQ BEND	2
10	30.0217	.CLAMP, WIRE MT ADH. 1/2 GRAY	2
11	30.0323	.CONNECTOR, MP280 FEMALE BODY	1
12	30.0326	.CLIP, MP280 CONNECTOR	1
13	30.0037	.TYTON TIE, #50 .18 X 8 BLACK	2
14	31.0053	.SWITCH, ROCKER ON/OFF	1
15	32.0153	.HARNESS, WIRE WORK LIGHT	1

OPTIONS

ILLUSTRATED DRAWING 70.3045 Strobe Light Kit

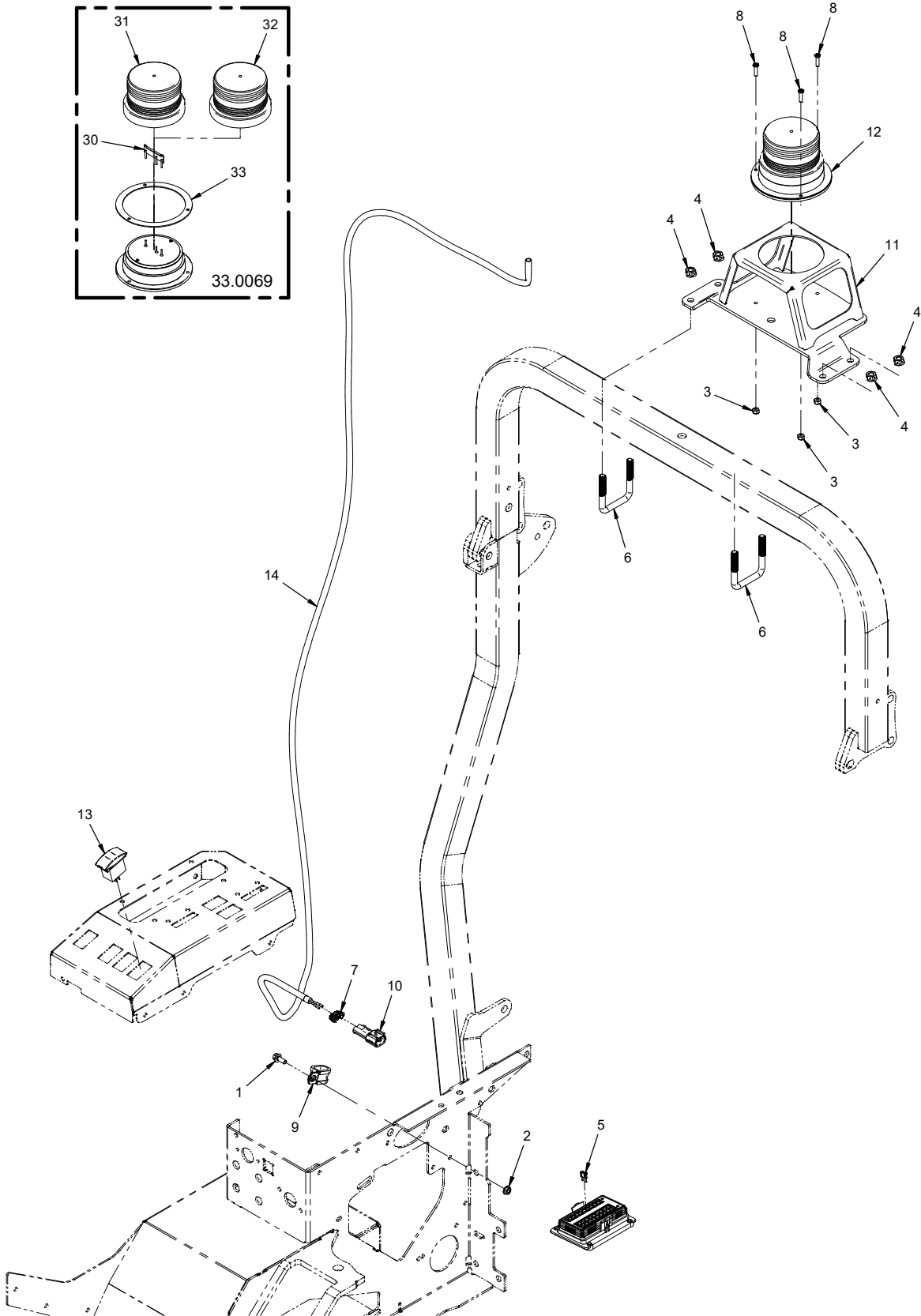

OPTIONS

70.3045 Strobe Light Kit

REF.	PART NO.	DESCRIPTION	QTY.
1	99.SF0405-1	.BOLT, SMF 1/4-20 X 5/8	1
2	99.SF04	.NUT, SRF 1/4-20 USS	1
3	99.A1032N	.LOCKNUT, NYLON 10-32 STAINLESS	3
4	99.E0082	.NUT, LOCKING FLANGE 3/8-16	4
5	30.0334	.FUSE, 15 AMP MINI BLUE	1
6	11.0053	.U-BOLT, 3/8-16 2-1/16" ID SQ BEND	2
7	30.0326	.CLIP, MP280 CONNECTOR	1
8	99.K0047	.MACHINE SCREW, #10-32 X 3/4	3
9	11.0046	.CLAMP, CUSHIONED METAL 1/2"	1
10	30.0322	.CONNECTOR, MP280 MALE BODY	1
11	62.1411	.FRAME, STROBE LIGHT	1
12	33.0049	.LIGHT, STROBE AMBER	1
13	31.0053	.SWITCH, ROCKER ON/OFF	1
14	32.0154	.HARNESS, WIRE STROBE LIGHT	1
30	33.0052	.BULB, STROBE LIGHT FOR 33.0049	1
31	33.0050	.LENS, STROBE - AMBER 3-1/2"	1
32	33.0051	.LENS, STROBE - BLUE 3-1/2" (Optional)	1
33	33.0049-1	.RING, CLAMP	1

OPTIONS

ILLUSTRATED DRAWING 70.3046 Directional / Hazard Light Kit

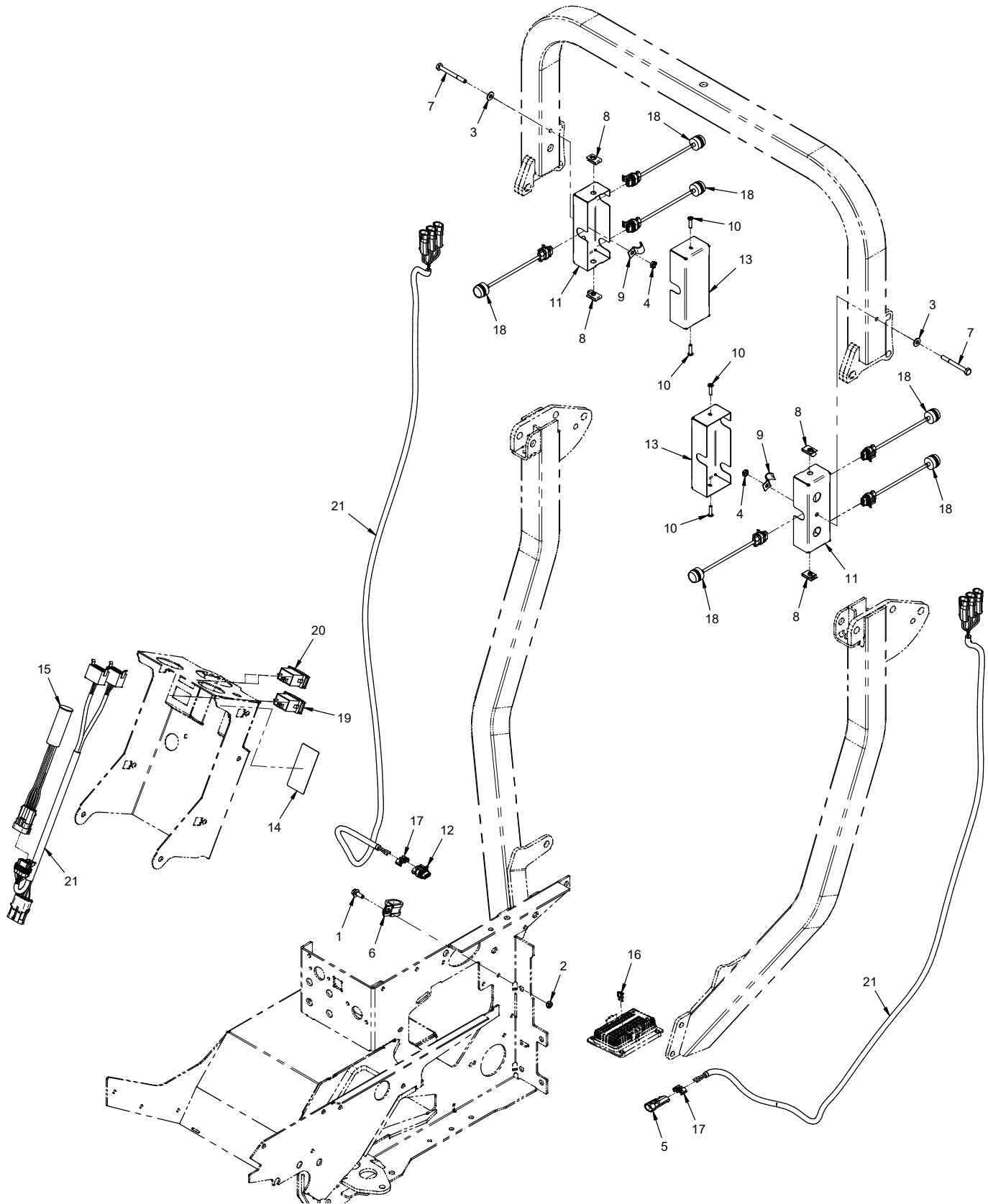

OPTIONS

70.3046 Directional / Hazard Light Kit

REF.	PART NO.	DESCRIPTION	QTY.
1	99.SF0405-1	.BOLT, SMF 1/4-20 X 5/8	1
2	99.SF04	.NUT, SRF 1/4-20 USS	1
3	95.04	.WASHER, FLAT 1/4 SAE	2
4	99.A04	.LOCKNUT, STOVER 1/4-20 USS	2
5	30.0365	.CONNECTOR, MP150 2 POS MALE	1
6	11.0046	.CLAMP, CUSHIONED METAL 1/2"	1
7	90.0420	.BOLT, 1/4-20 USS X 2-1/2"	2
8	99.E0091	.NUT, "U" #10-24 EXTRUDED	4
9	11.0072	.CLAMP, 1/2 LOOP VINYL	2
10	99.K0106	.MACHINE SCREW, #10-24 X 3/4	4
11	64.1818	.BRACKET, DIRECTION LIGHT MT.	2
12	30.0344	.CONNECTOR, MP150 FEMALE BODY	1
13	60.1241	.COVER, DIRECTIONAL LIGHT	2
14	00.0378	.DECAL, DIRECTIONAL/HAZARD	1
15	35.0127	.MODULE, DIRECTIONAL LIGHT	1
16	30.0333	.FUSE, 10 AMP MINI RED	1
17	30.0409	.CLIP, MP150 CONNECTOR 2 POS	2
18	33.0067-1	.LIGHT, LED 3W ROUND - AMBER	6
19	31.0053	.SWITCH, ROCKER ON/OFF	1
20	31.0055	.SWITCH, ROCKER ON/OFF/ON	1
21	32.0155	.HARNESS, WIRE DIRECTIONAL	1

OPTIONS

ILLUSTRATED DRAWING 70.3037 Backup Alarm Kit

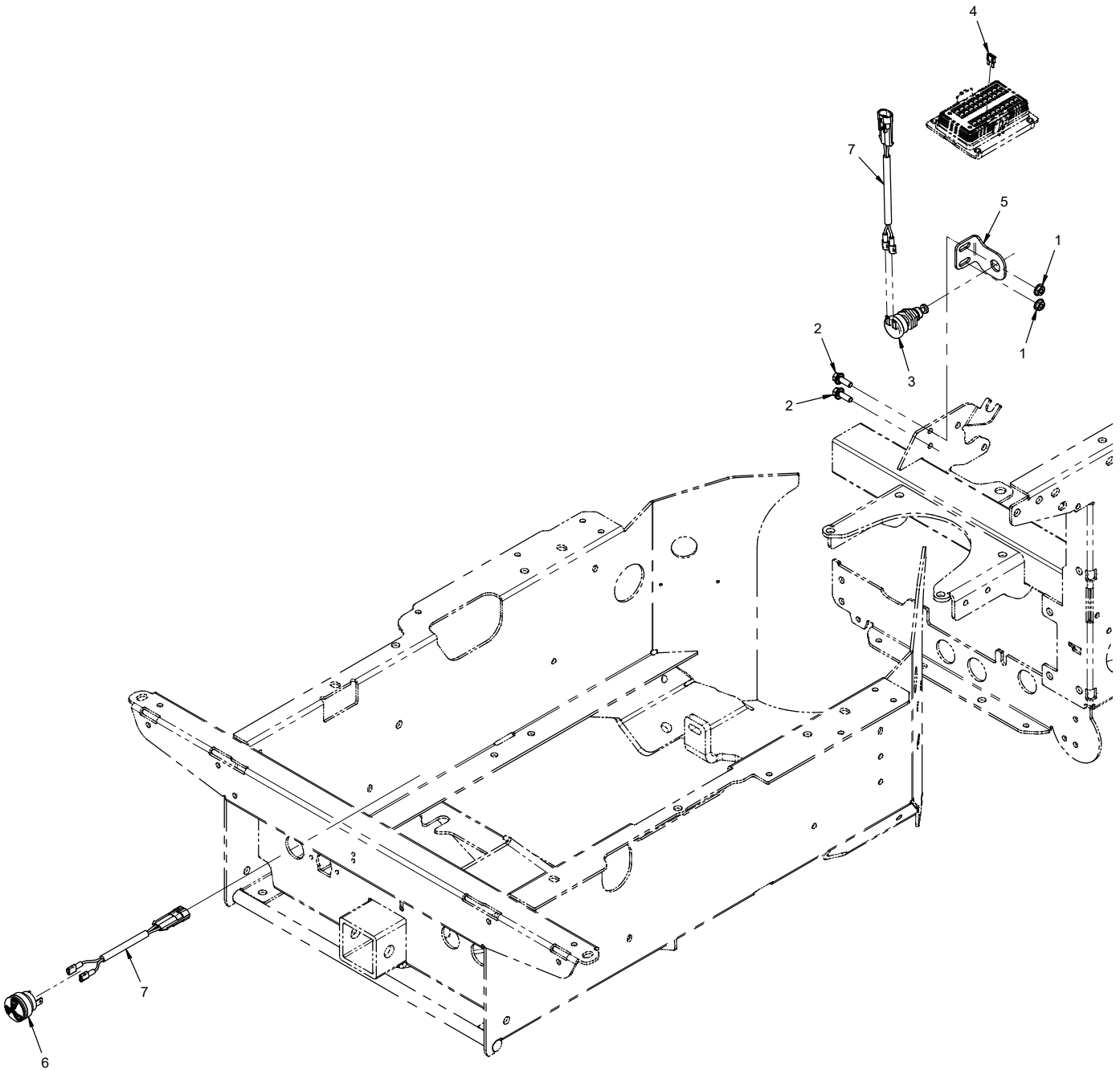

OPTIONS

70.3037 Backup Alarm Kit

REF.	PART NO.	DESCRIPTION	QTY.
1	99.SF04	.NUT, SRF 1/4-20 USS.	2
2	99.SF0406-1	.BOLT, SMF 1/4-20 X 3/4	2
3	31.0044	.SWITCH, PUSH BUTTON - NEUTRAL.	1
4	30.0333	.FUSE, 10 AMP MINI RED.	1
5	64.1785	.BRACKET, BACKUP SWITCH MOUNT	1
6	35.0125	.ALARM, AUDIBLE PULSE PANEL MT	1
7	32.0149	.HARNESS, WIRE BACKUP ALARM.	1

OPTIONS

ILLUSTRATED DRAWING 70.3036 12 Volt Front Kit

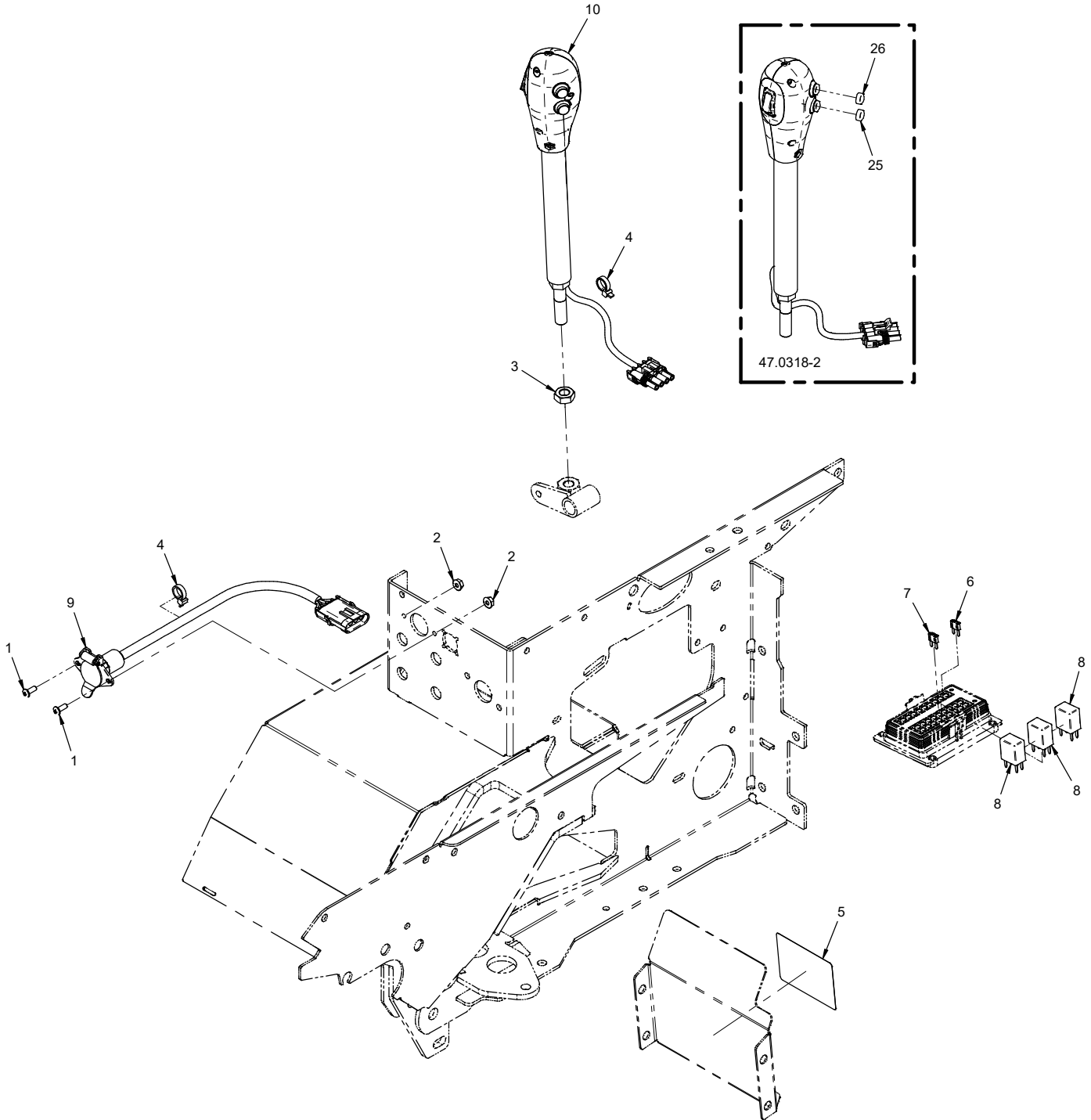

OPTIONS

70.3036 12 Volt Front Kit

REF.	PART NO.	DESCRIPTION	QTY.
1	99.K0062	.MACHINE SCREW, #10-32 X 1/2	2
2	99.E0035	.NUT, SRF #10-32	2
3	99.E0058	.NUT, JAM 1/2-13 USS	1
4	30.0037	.TYTON TIE, #50 .18 X 8 BLACK	2
5	00.0328	.DECAL, HANDLE 12V	1
6	30.0332	.FUSE, 5 AMP MINI TAN	1
7	30.0334	.FUSE, 15 AMP MINI BLUE	1
8	35.0117	.RELAY, 12V 35/20 AMP 280 MICRO	3
9	32.0148	.HARNESS, WIRE 12V FRONT	1
10	47.0318-2	.HANDLE, SDLA GRIP & POST 3400	1
25	47.0349	.BUTTON, SWITCH ORANGE (1/4" TALL)	1
25	47.0427	.BUTTON, SWITCH ORANGE (1/8" TALL)	1
26	47.0348	.BUTTON, SWITCH YELLOW (1/4" TALL)	1
26	47.0426	.BUTTON, SWITCH YELLOW (1/8" TALL)	1

OPTIONS

ILLUSTRATED DRAWING 70.3050 12 Volt Rear Kit

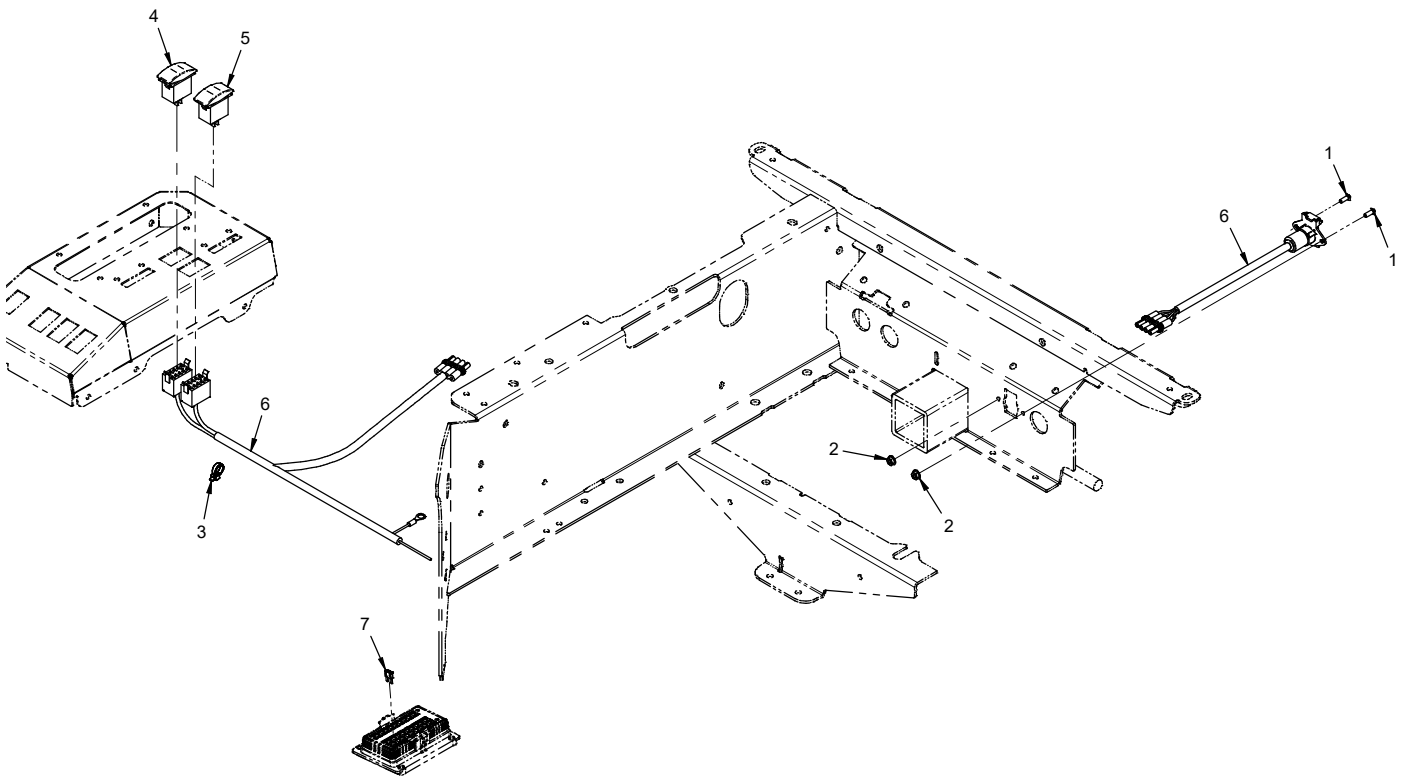

OPTIONS

70.3050 12 Volt Rear Kit

REF.	PART NO.	DESCRIPTION	QTY.
1	99.K0062	MACHINE SCREW, #10-32 X 1/2	2
2	99.E0035	NUT, SRF #10-32	2
3	30.0037	TYTON TIE, #50 .18 X 8 BLACK	4
4	31.0053	SWITCH, ROCKER ON/OFF	1
5	31.0056	SWITCH, ROCKER (ON)/OFF/(ON)	1
6	32.0156	HARNESS, WIRE 12V REAR	1
7	30.0334	FUSE, 15 AMP MINI BLUE	1

OPTIONS

ILLUSTRATED DRAWING 70.3041 Horn Kit

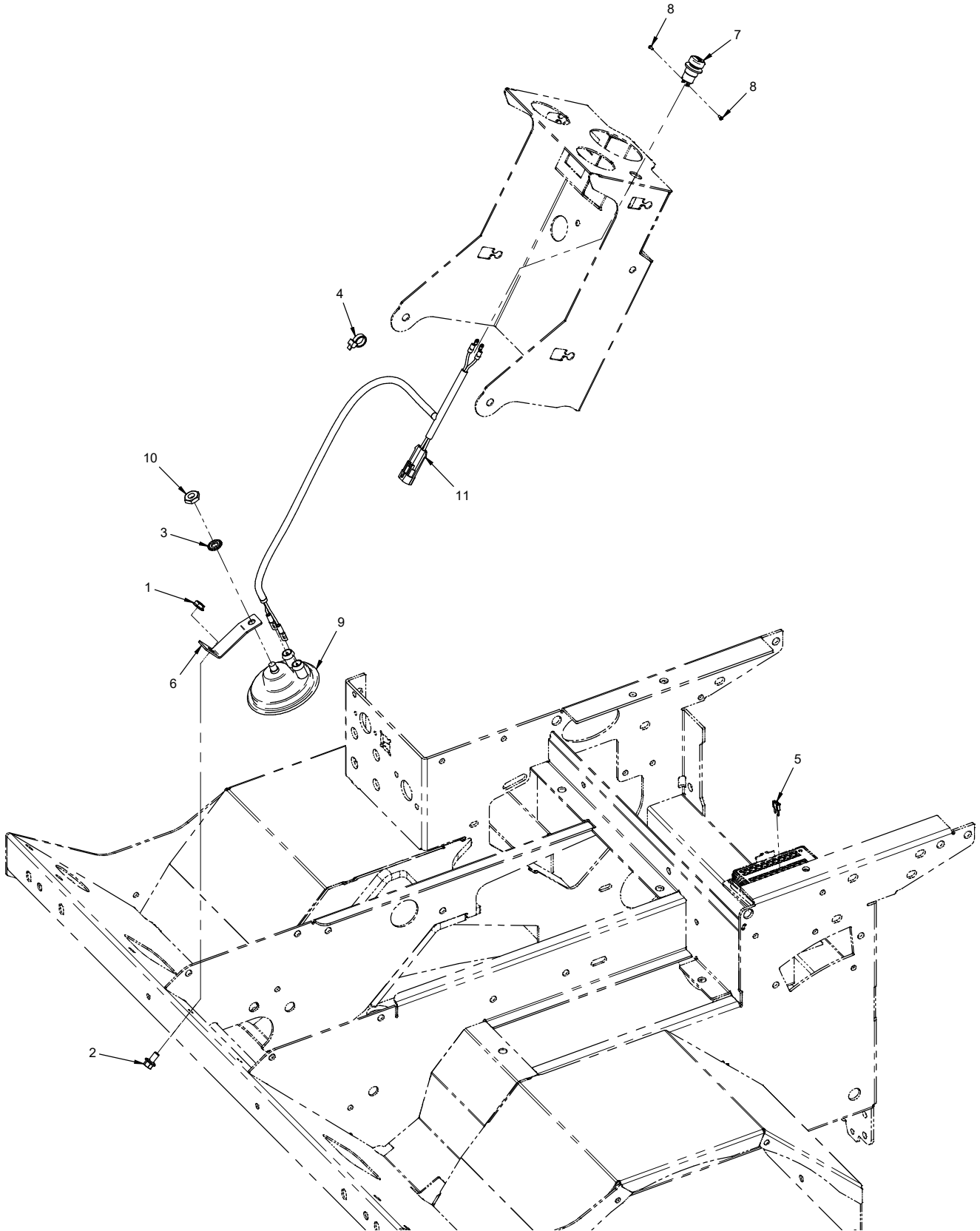

OPTIONS

70.3041 Horn Kit

REF.	PART NO.	DESCRIPTION	QTY.
1	99.SF04	.NUT, SRF 1/4-20 USS.	1
2	99.SF0404-1	.BOLT, SMF 1/4-20 X 1/2	1
3	99.G0003	.WASHER, STAR-EXTERNAL 5/16	1
4	30.0037	.TYTON TIE, #50 .18 X 8 BLACK	3
5	30.0332	.FUSE, 5 AMP MINI TAN	1
6	64.1801	.BRACKET, HORN MOUNT	1
7	31.0057	.SWITCH, HORN	1
8	99.K0125	.MACHINE SCREW, #2-56 X 3/16.	2
9	33.0066	.HORN, DISC LOW TONE	1
10	99.M0043	.NUT, JAM M10 X 1.5.	1
11	32.0152	.HARNES, WIRE HORN	1

OPTIONS

ILLUSTRATED DRAWING 70.3039 Dual Front Hydraulic Auxiliary Kit

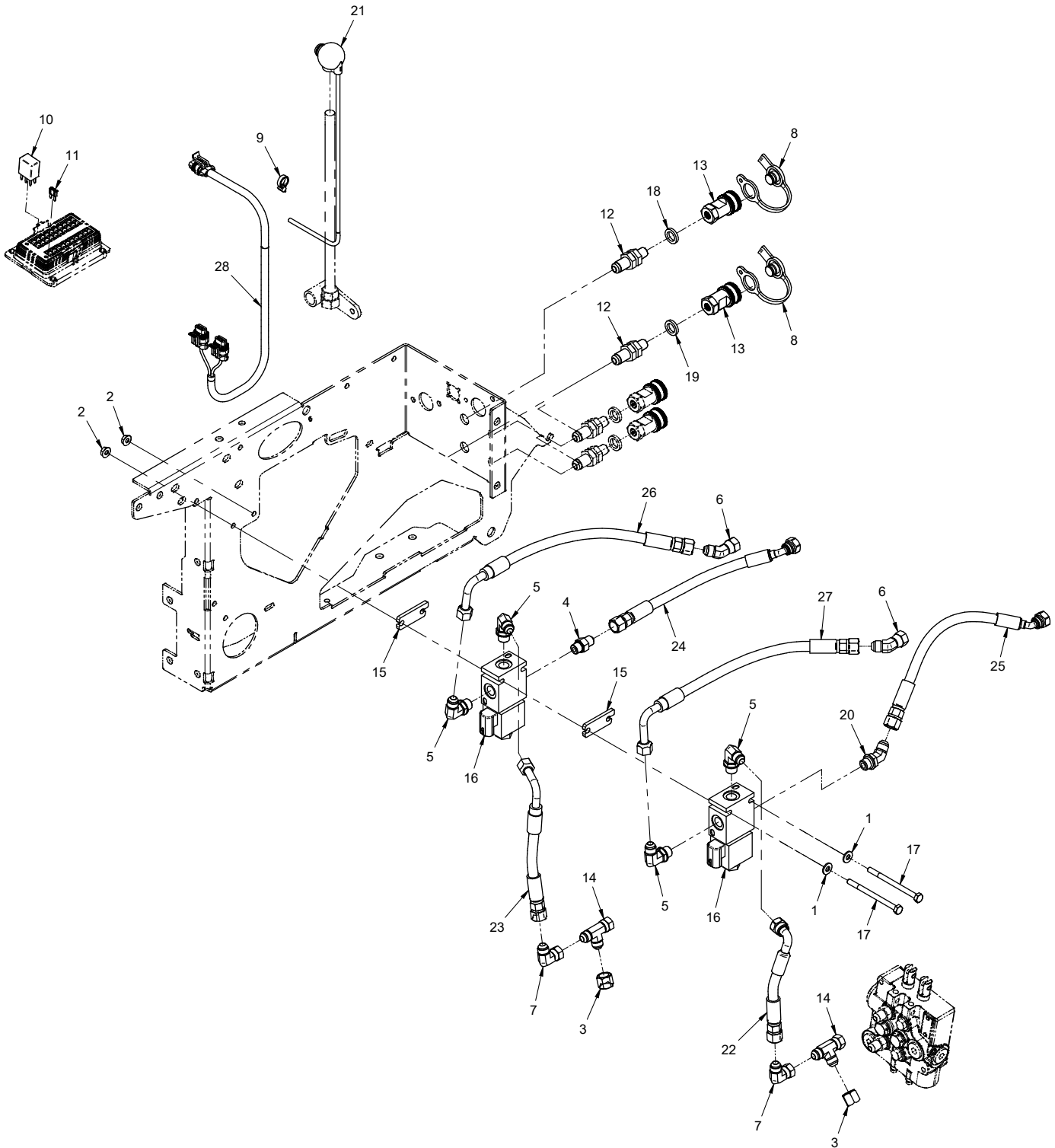

OPTIONS

70.3039 Dual Front Hydraulic Auxiliary Kit

REF.	PART NO.	DESCRIPTION	QTY.
1	95.04	.WASHER, FLAT 1/4 SAE	2
2	99.SF04	.NUT, SRF 1/4-20 USS	2
3	25.304-C-06	.FITTING, CAP 3/8 #6 JIC	2
4	25.6400-06-06	.FITTING, M CONN 3/8 X 3/8	1
5	25.6801-06-06	.FITTING, 90 ME 3/8 X 3/8	4
6	25.6502-06-06	.FITTING, 45 MFE 3/8 X 3/8	2
7	25.6500-06-06	.FITTING, 90 MFE 3/8 X 3/8	2
8	23.0126	.PLUG, DUST FOR 23.0106	2
9	30.0037	.TYTON TIE, #50 .18 X 8 BLACK	5
10	35.0117	.RELAY, 12V 35/20 AMP 280 MICRO	1
11	30.0333	.FUSE, 10 AMP MINI RED	1
12	25.2706-04-06LN	.FITTING, BULKHEAD W/ LOCKNUT	2
13	23.0106	.COUPLER, HYDRAULIC QUICK - 1/4 FEMALE	2
14	25.6602-6-6-6	.FITTING, TEE SINGLE SWIVEL 3/8	2
15	64.1649	.PLATE, SPACER HYD VALVE	2
16	23.0164	.VALVE, DIRECTIONAL 12V	2
17	90.0428	.BOLT, 1/4-20 USS X 3-1/2"	2
18	05.0156	.WASHER, .544ID X .817 X 14 NAT	1
19	05.0157	.WASHER, .544 X .817 X 14 BLK	1
20	25.6802-06-06	.FITTING, 45 ME 3/8 X 3/8	1
21	47.0336	.HANDLE, GRIP W/SWITCH	1
22	20.0316	.HOSE, 1/4X5.750 SAE 100R17 AR	1
23	20.0315	.HOSE, 1/4X8.00 SAE 100R17 AR	1
24	20.0310	.HOSE, 1/4X12.00 SAE 100R17 AR	1
25	20.0310	.HOSE, 1/4X12.00 SAE 100R17 AR	1
26	20.0317	.HOSE, 1/4X14.00 SAE 100R17 AR	1
27	20.0317	.HOSE, 1/4X14.00 SAE 100R17 AR	1
28	32.0151	.HARNESS, DUAL HYDRAULIC	1

OPTIONS

ILLUSTRATED DRAWING Dual Front Hydraulic Auxiliary Diagram

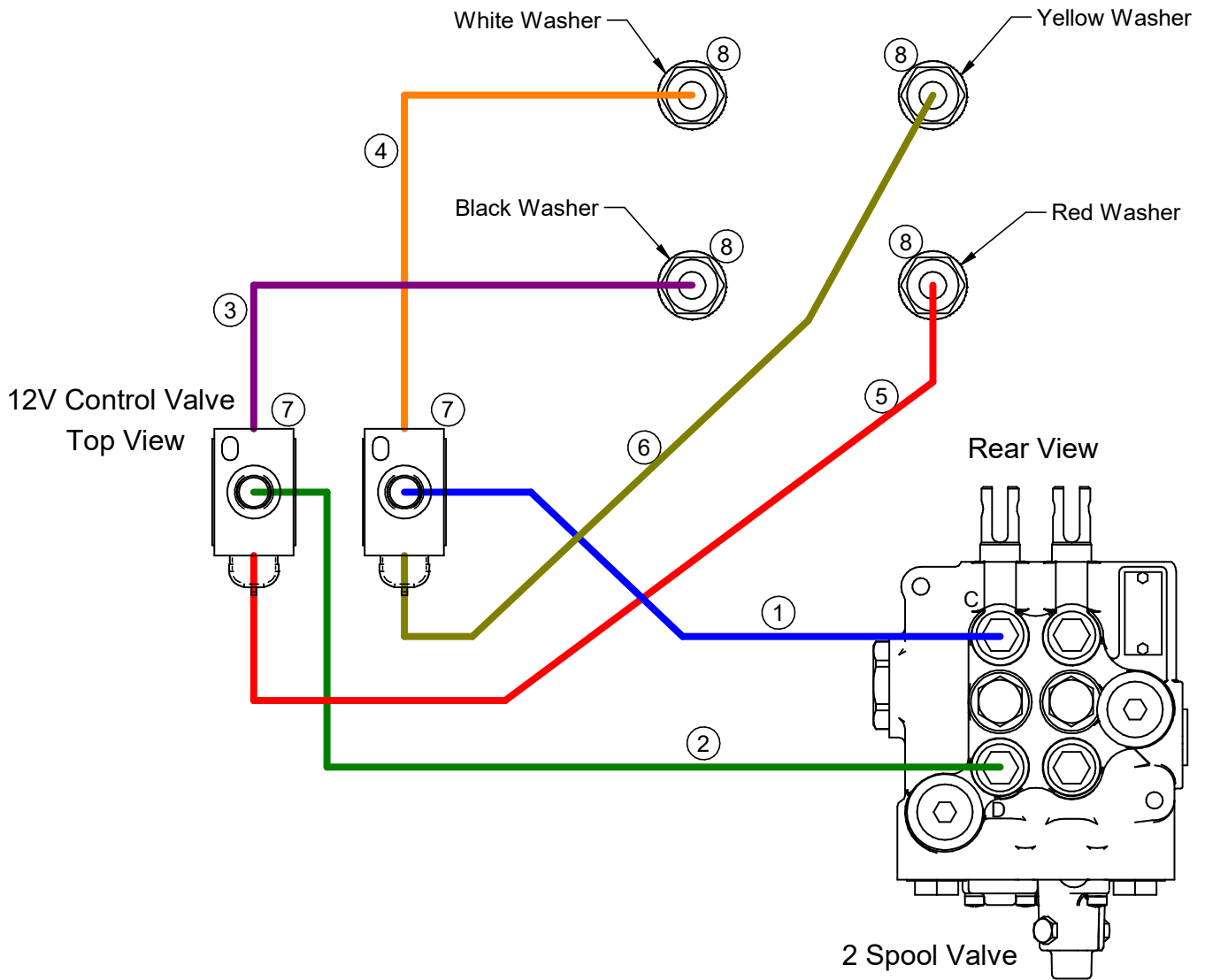

OPTIONS

Dual Front Hydraulic Auxiliary Diagram

REF.	PART NO.	DESCRIPTION	QTY.
1	20.0316	.HOSE, 1/4X5.75 SAE 100R17 AR	1
2	20.0315	.HOSE, 1/4X8.00 SAE 100R17 AR	1
3	20.0310	.HOSE, 1/4X12.00 SAE 100R17 AR	1
4	20.0310	.HOSE, 1/4X12.00 SAE 100R17 AR	1
5	20.0317	.HOSE, 1/4X14.00 SAE 100R17 AR	1
6	20.0317	.HOSE, 1/4X14.00 SAE 100R17 AR	1
7	23.0164	.VALVE, DIRECTIONAL 12V	2
8	23.0106	.COUPLER, HYDRAULIC QUICK - 1/4 FEMALE	4

OPTIONS

ILLUSTRATED DRAWING 70.3040 Suspension Seat Kit

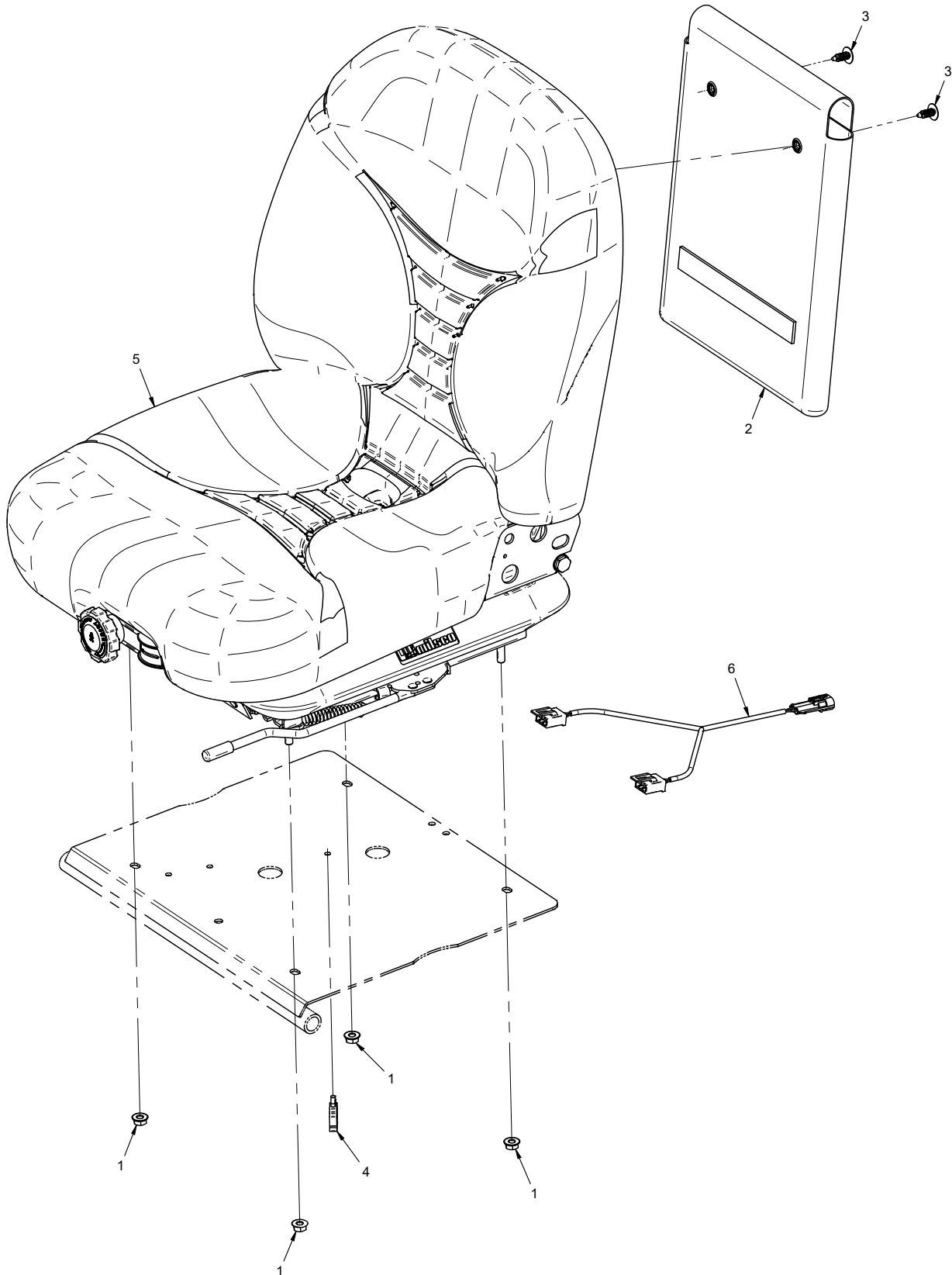

OPTIONS

70.3040 Suspension Seat Kit

REF.	PART NO.	DESCRIPTION	QTY.
1	99.SF05	.NUT, SRF 5/16-18 USS	4
2	47.0362	.POUCH, LITERATURE	1
3	04.0035	.RIVET, PLASTIC 1/4	2
4	30.0135	.CLAMP, LOOM 3/8 ROSEBUD MOUNT	1
5	47.0324	.SEAT, SUSPENSION	1
	31.0062	.SWITCH, SEAT WITH RUBBER BOOT	2
6	32.0143	.HARNESS, 3400/4500 SEAT	1

OPTIONS

ILLUSTRATED DRAWING 70.2016 Trailer Mover Hitch

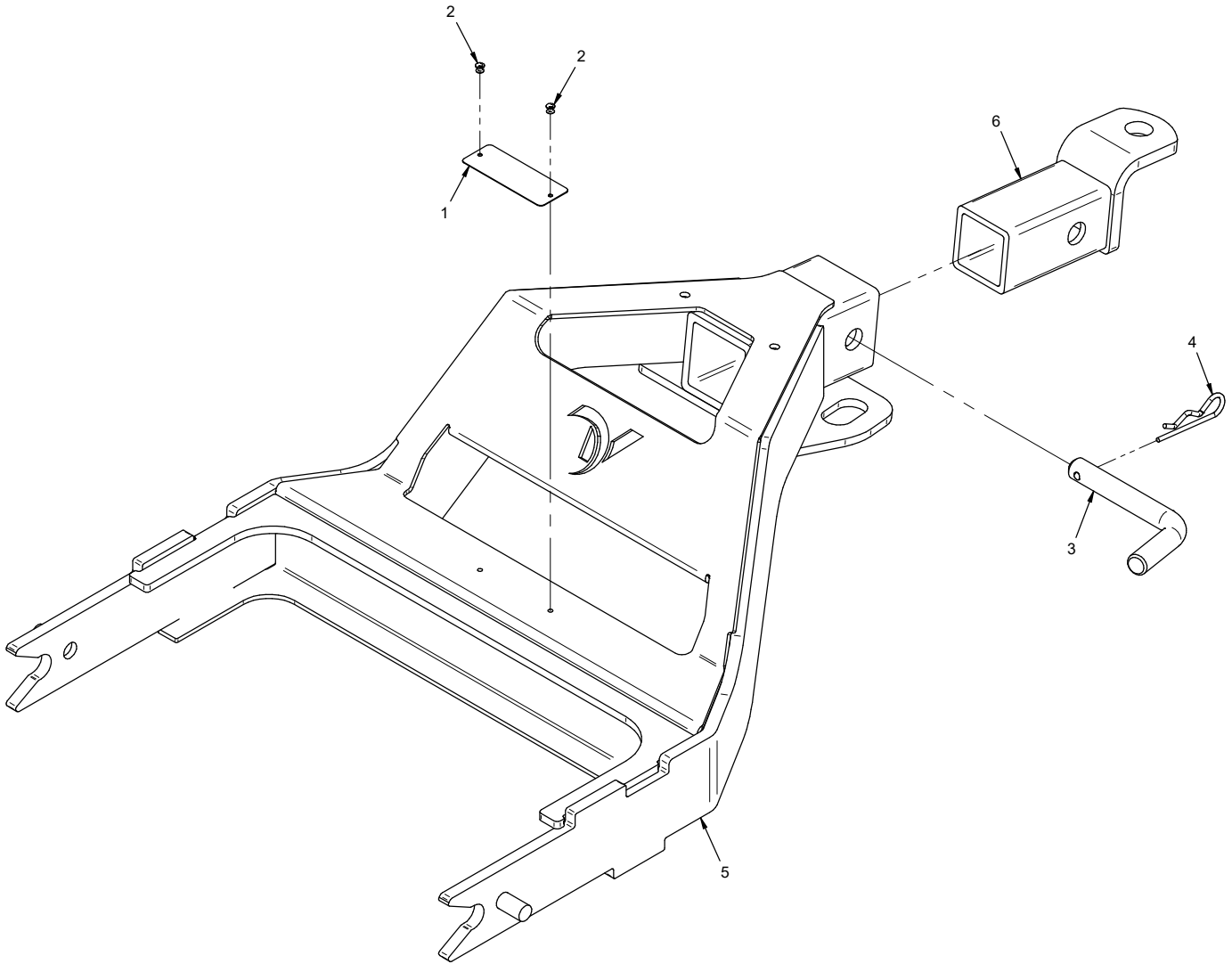

OPTIONS

70.2016 Trailer Mover Hitch

REF.	PART NO.	DESCRIPTION	QTY.
1	N/A	.PLATE, VENTRAC SERIAL NUMBER	1
2	04.0007	.RIVET, POP DOME 1/8 X 1/8 S.S.	2
3	03.0014	.PIN, HITCH 5/8" X 3" USABLE	1
4	02.HP0420	.HAIRPIN, 1/8 X 2 1/2	1
5	62.1461	.FRAME, TOW HITCH	1
6	62.0968	.HITCH, REAR	1