

Operator's Manual

2120M





500 Venture Drive
Orrville, OH 44667
www.ventrac.com

View all manuals



Visit ventrac.com/manuals for the latest version of this operator's manual.

A downloadable parts manual is also available.

To the Owner Contact Information and Product Identification

If you need to contact an authorized Ventrac dealer for information on servicing your product, always provide the product model and serial numbers.

Please fill in the following information for future reference. See the picture(s) below to find the location of the identification numbers. Record them in the spaces provided.

Date of Purchase: _____

Dealer: _____

Dealer Address: _____

Dealer Phone Number: _____

Dealer Fax Number: _____

Model # (A): _____

Serial # (B): _____

Engine Serial # (C) _____



Behind the Shield

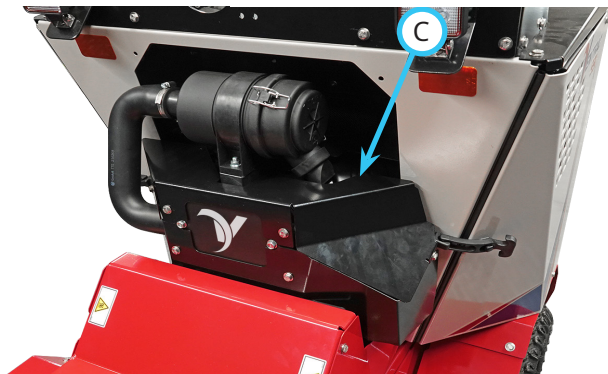

Venture Products Inc. reserves the right to make changes in design or specifications without obligation to make like changes on previously manufactured products.

TABLE OF CONTENTS

INTRODUCTION	PAGE 6
Product Description	6
Why Do I Need an Operator’s Manual?	6
Using Your Manual	7
Manual Glossary	7
SAFETY	PAGE 8
General Safety Procedures	8
Training Required	8
Requirements for Personal Protective Equipment (PPE)	8
Operation Safety.	8
Keep Riders Off	10
Operating On Slopes	10
Truck Or Trailer Transport	10
Maintenance	10
Fuel Safety	11
Hydraulic Safety	12
California Proposition 65	13
Operator Safety Interlock System	13
2120 Safety Procedures.	13
Safety Decals	15
OPERATIONAL CONTROLS	PAGE 18
Standard Control Locations	18
Optional Control Locations	18
Cluster Gauge (A)	19
Ignition Switch (B)	19
USB Receptacle (C).	19
Headlight Switch (D).	19
Drive Control Handles (E).	19
Latch (Front Control Grab Handles)	20
Throttle Lever (G)	20
Choke Handle (H)	20
Heated Hand Grip Switch (I)	20
Hydraulic Control Handle (J)	20
Parking Brake (K)	20
Attachment Latch Handle (L).	21
Latch Handle Lock (M).	21
Auxiliary Hydraulic Quick Couplers (N)	21
Circuit Breaker and Battery Disconnect (O).	21
Fuel Shut-off Valve (P).	21
Rear Work Light Switch (AA)	21
Strobe Light Switch (BB)	21
Power Take Off (PTO) Switch (CC)	21
Brine Pump Switch (DD)	21
Front 12V Switch and 4-Pin Outlet (EE, FF)	22
Horn Switch (GG)	22
Dual Front Hydraulic Auxiliary Switch (HH)	22
Dual Front Hydraulic Auxiliary Valve (II).	22
Weight Transfer Selector Handle (JJ).	22
Attachment Belt Tension Spring (KK)	22
Backup Alarm (LL)	22

TABLE OF CONTENTS

GENERAL OPERATION	PAGE 23
Daily Inspection	23
Starting the Engine	23
Forward and Reverse	23
Turning (Left, Right, and Turn in Place)	24
Stopping the Power Unit	24
Shutting Off the Engine	24
Attaching	25
Detaching	26
Operating Attachments	26
Front Hitch	26
Front Auxiliary Couplers	26
Weight Transfer (Optional Accessory)	27
Front 12 Volt 4-Pin Outlet (Optional Accessory)	27
Operator Cushion Height Adjustment	27
Towing or Pushing the Power Unit	27
SERVICE	PAGE 28
Service and General Maintenance	28
Cleaning and Appearance Care	28
Service Access Points	29
Lubrication Locations	29
Checking the Hydraulic Oil Level	30
Changing the Hydraulic Oil and Filters	31
Servicing the Hydraulic Oil Cooler	32
Checking the Engine Oil Level	32
Changing the Engine Oil and Filter	33
Air Filter Service and Replacement	34
Filling the Fuel Tank	34
Changing the Fuel Filter	35
Cleaning the Engine Compartment and Engine	35
Servicing the Battery	35
Removing the Battery	36
Installing the Battery	36
Cleaning the Battery and Terminals	36
Charging the Battery	36
Jump Starting Procedure	36
Replacing Fuses	37
Replacing the Head Lights	37
Replacing the Tail Lights	37
Replacing the Work Lights	37
Replacing the Strobe Lights	38
Strobe Light Synchronization	38
Changing the Strobe Light Flash Pattern	38
Belt Inspection	38
Pump Drive Belt Replacement	39
PTO Drive Belt Replacement	40
Wheel Removal	40
Wheel Installation	40
Tire Pressure	40
Parking Brake Adjustment	40
Parking Brake Switch Adjustment	41

TABLE OF CONTENTS

Operator Presence Switch Adjustment	41
Drive Control Handle and Neutral Lock Rocker Arm Adjustment	42
Backup Alarm Switch Adjustment	43
Weight Transfer Spring Inspection and Adjustment.	44
Storage	44
Maintenance Schedule	46
Maintenance Checklist	47
Maintenance Log	48

TROUBLESHOOTING **PAGE 50**

Engine.	50
Electrical	51
Hydraulic	51
Power Unit	52

SPECIFICATIONS **PAGE 53**

Engine.	53
Electrical	53
Power Train.	53
Controls and Instrument Panel	53
Other Features.	53
Dimensions.	54
Fluid Capacities and Specifications	54
Belt Chart.	54

INTRODUCTION



Venture Products Inc. is pleased to provide you with your new Ventrac power unit! We hope that Ventrac equipment will provide you with a ONE Tractor Solution.

Please visit our website, or contact your authorized Ventrac dealer for a complete list of items available for your new power unit.

Product Description

The Ventrac 2120 SSV is a dedicated sidewalk snow vehicle with a 4x4 skid steer drive system.

The 86.4 cm (34 inch) working width of the Ventrac 2120 allows access to sidewalks and transitional areas, reducing the need for hand labor.

The Ventrac 2120 is designed with a full arsenal of snow removal attachments and de-icing options. A self-aligning front hitch allows quick and easy mounting of snow removal attachments.

An optional PTO kit is available for powered attachments.

Why Do I Need an Operator's Manual?

This manual has been created to help you gain the important knowledge of what is needed to safely operate and maintain your machine, and to avoid injury and product damage. It is divided into chapters for convenient reference of the appropriate information.

You must read and understand the operator's manual for each piece of Ventrac equipment you own. Reading the operator's manual will help you become familiar with each specific piece of equipment. If this manual becomes damaged or unreadable, it should be replaced immediately. Contact your local Ventrac dealer for a replacement.

When using a Ventrac attachment, be sure to read and follow the safety and operating instructions of both the power unit and the attachment being used to ensure the safest operation possible.

The information in this manual provides the operator with the safest procedures to operate the machine while getting the maximum use out of the unit. Failure to follow the safety precautions listed in this manual may result in personal injury and/or damage to the equipment.

INTRODUCTION

Using Your Manual

This manual identifies potential hazards and safety concerns to help you, as well as others, avoid personal injury and/or damage to the equipment.

Safety should always be the first priority when working on or operating equipment. Accidents are more likely to occur when proper operating procedures are not followed or inexperienced operators are involved.

SYMBOL DEFINITIONS



This symbol identifies potential health and safety hazards. It marks safety precautions. Your safety and the safety of others is involved.

There are three signal words that describe the level of safety concern: Danger, Warning, and Caution.

SIGNAL WORD DEFINITIONS

DANGER

Indicates an imminently hazardous situation which, if not avoided, will result in death or serious injury. This signal word is limited to the most extreme cases.

WARNING

Indicates a potentially hazardous situation which, if not avoided, could result in death or serious injury.

CAUTION

Indicates a potentially hazardous situation which, if not avoided, may result in minor or moderate injury and/or property damage. It may also be used to alert against unsafe practices.

This manual also uses two words to highlight information. **ATTENTION** calls attention to special mechanical information to prevent equipment damage and/or best practices for equipment service and care.

NOTE emphasizes general information that is worthy of special attention.

Note: Right-Hand and Left-Hand orientations may be referred to at different places throughout this manual. Right-Hand and Left-Hand is determined as if facing forward from the operator station.

Manual Glossary

- Power Unit** A Ventrac tractor or other Ventrac engine powered device that may be operated by itself or with an attachment or accessory.
- Attachment** A piece of Ventrac equipment that requires a Power Unit for operation.
- Accessory** A device that attaches to a Power Unit or Attachment to extend its capabilities.
- Machine** Describes any "Attachment" or "Accessory" that is used in conjunction with a power unit.

SAFETY



General Safety Procedures for Ventrac SSV Power Units, Attachments, & Accessories



Training Required

- The owner of this machine is solely responsible for properly training the operators.
- The owner/operator is solely responsible for the operation of this machine and for the prevention of accidents or injuries occurring to him/herself, other people, or property.
- Do not allow operation or service by children or untrained personnel. Local regulations may restrict the age of the operator.
- Before operating this machine, read the operator's manual and understand its contents.
- If the operator of the machine cannot understand this manual, then it is the responsibility of this machine's owner to fully explain the material within this manual to the operator.
- Learn and understand the use of all the controls.
- Know how to stop the power unit and the attachments quickly in the event of an emergency.

Requirements for Personal Protective Equipment (PPE)

- The owner is responsible for ensuring that all the operators use the proper PPE while operating the machine. Whenever you use the machine, use the following PPE:
- Certified eye protection and hearing protection.
- Closed toe, slip resistant footwear.
- Long pants or trousers.
- A dust mask for dusty conditions.
- Appropriate cold weather clothing.
- Additional PPE may be required. Refer to the product safety procedures for any additional requirements.

Operation Safety

- Secure long hair and loose clothing. Do not wear jewelry.
- Inspect the machine before operation. Repair or replace any damaged, worn, or missing parts. Be sure the guards and shields are in proper working condition and are secured in place. Make any necessary adjustments before operating the machine.
- Some pictures in this manual may show shields or covers opened or removed in order to clearly illustrate the instructions. Under no circumstance should the machine be operated without these devices in place.
- Alterations or modifications to this machine can reduce safety and could cause damage to the machine. Do not alter the safety devices or operate with the shields or covers removed.
- Before each use, verify that all the controls function properly and inspect all the safety devices. Do not operate if the controls or safety devices are not in proper working condition.
- Check the parking brake function before operating. Repair or adjust the parking brake if necessary.
- Observe and follow all of the safety decals.
- All the controls are to be operated from the operator's station only.
- Ensure the attachment or accessory is locked or fastened securely to the power unit before operating.
- Ensure that all bystanders are clear of the power unit and the attachment before operating. Stop the machine if someone enters your work area.

SAFETY



General Safety Procedures for Ventrac Power Units, Attachments, & Accessories



- Always be alert to what is happening around you, but do not lose focus on the task you are performing. Always look in the direction the machine is moving.
- Look behind and down before backing up to be sure of a clear path.
- If you hit an object, stop and inspect the machine. Make any necessary repairs before operating the machine again.
- Stop operation immediately at any sign of equipment failure. An unusual noise can be a warning of equipment failure or a sign that maintenance is required. Make any necessary repairs before operating the machine again.
- Do not leave the machine unattended while it is running.
- Always park the machine on level ground.
- Always shut off the engine when connecting the attachment drive belt to the power unit.
- Never leave the operator's station without lowering the attachment to the ground, engaging the parking brake, shutting off the engine, and removing the ignition key. Make sure all moving parts have come to a complete stop before dismounting.
- Never leave the machine unattended without lowering the attachment to the ground, engaging the parking brake, shutting off the engine, and removing the ignition key.
- Only operate in well-lit conditions.
- Do not operate when there is a risk of lightning.
- Never direct the discharge of any attachment in the direction of people, buildings, animals, vehicles, or other objects of value.
- Never discharge material against a wall or obstruction. The material may ricochet back toward the operator.
- Use extra caution when approaching blind corners, shrubs, trees, or other objects that may obscure your vision.
- Do not run the engine in a building without adequate ventilation.
- Do not touch the engine or the muffler while the engine is running or immediately after stopping the engine. These areas may be hot enough to cause a burn.
- Do not change the engine governor settings or over-speed the engine. Operating the engine at excessive speeds may increase the hazard of personal injury.
- To reduce the hazard of fire, keep the battery compartment, engine, and muffler areas free of grass, leaves, excessive grease, and other flammable materials.
- Clear the working area of objects that might be hit or thrown from the machine.
- Keep people and pets out of the working area.
- Know the work area well before operation. Do not operate where traction or stability is questionable.
- Reduce speed when you are operating over rough ground.
- Equipment can cause serious injury and/or death when improperly used. Before operating, know and understand the operation and safety of the power unit and the attachment being used.
- Do not operate the machine if you are not in good physical and mental health, if you will be distracted by personal devices, or if you are under the influence of any substance which might impair your decisions, dexterity, or judgment.

SAFETY



General Safety Procedures for Ventrac Power Units, Attachments, & Accessories



- Children are attracted to machine activity. Be aware of children and do not allow them in the work area. Turn off the machine if a child enters the work area.
- Power units, attachments, and accessories are not designed or intended for travel on public roadways. Never operate or travel on public roads or highways.
- Operate with safety lights when operating near roadways.
- Slow down and be careful of traffic when operating near or crossing roadways. Stop before crossing roads or sidewalks. Use care when approaching areas or objects that may obscure vision.

Keep Riders Off

- Only allow the operator on the power unit. Keep riders off.
- Never allow riders on any attachment or accessory.

Operating On Slopes

- Slopes can cause loss-of-control and tip-over accidents, which can result in severe injury or death. Be familiar with the emergency parking brake, along with the power unit controls and their functions.
- Do not operate on slopes greater than 10 degrees.
- Do not stop or start suddenly when operating on slopes.
- Variables such as wet surfaces and loose ground will reduce the degree of safety. Do not drive where the machine could lose traction or tip over.
- Keep alert for hidden hazards in the terrain.
- Stay away from drop-offs, ditches, and embankments.
- Sharp turns should be avoided when operating on slopes.
- Transport the machine with the attachment lowered or close to the ground to improve stability.
- While operating on slopes, drive in an up and down direction whenever possible. If turning is necessary while driving across slopes, reduce your speed and turn slowly in the downhill direction.

Truck Or Trailer Transport

- Use care when loading or unloading the machine into a truck or trailer.
- Use full width ramps for loading the machine into a truck or trailer.
- The parking brake is not sufficient to lock the machine during transport. Always secure the power unit and/or attachment to the transporting vehicle securely using straps, chains, cables, or ropes. Both the front and rear straps should be directed down and outward from the machine.
- Shut off the fuel supply to the power unit during transport on a truck or trailer.
- Turn the battery disconnect switch to the Off position to shut off electrical power.

Maintenance

- Keep the safety decals legible. Remove all grease, dirt, and debris from the safety decals and instructional labels.
- If any decals are faded, illegible, or missing, contact your dealer promptly for replacements.
- When new components are installed, be sure that the current safety decals are affixed to the replacement components.

SAFETY



General Safety Procedures for Ventrac Power Units, Attachments, & Accessories



- If any component requires replacement, use only original Ventrac replacement parts.
- Always turn the battery disconnect to the Off position or disconnect the battery before performing any repairs. Disconnect the negative terminal first and the positive terminal last. Reconnect the positive terminal first and the negative terminal last.
- Keep all bolts, nuts, screws, and other fasteners properly tightened.
- Always lower the attachment to the ground, engage the parking brake, shut off the engine, and remove the ignition key. Make sure all moving parts have come to a complete stop before cleaning, inspecting, adjusting, or repairing.
- If the power unit, attachment, or accessory requires repairs or adjustments not instructed in the operator's manual, the power unit, attachment, or accessory must be taken to an authorized Ventrac dealer for service.
- Never perform maintenance on the power unit and/or attachment if someone is in the operator's station.
- Always use protective glasses when handling the battery.
- Check the fuel lines for tightness and wear on a regular basis. Tighten or repair them as needed.
- To reduce the hazard of fire, keep the battery compartment, engine, and muffler areas free of grass, leaves, and excess grease.
- Do not touch the engine, the muffler, or other exhaust components while the engine is running or immediately after stopping the engine. These areas may be hot enough to cause a burn.
- Allow the engine to cool before storing and do not store near an open flame.
- Do not change the engine governor settings or over-speed the engine. Operating engine at excessive speeds may increase the hazard of personal injury.
- Springs may contain stored energy. Use caution when disengaging or removing springs and/or spring loaded components.
- An obstruction or blockage in a drive system or moving/rotating parts may cause a buildup of stored energy. When the obstruction or blockage is removed, the drive system or moving/rotating parts may move suddenly. Do not attempt to remove an obstruction or blockage with your hands. Keep your hands, feet, and clothing away from all power-driven parts.

Fuel Safety

- To avoid personal injury or property damage, use extreme care in handling gasoline. Gasoline is extremely flammable and the vapors are explosive.
- Do not refuel the machine while smoking or at a location near flames or sparks.
- Always refuel the machine outdoors.
- Do not store the machine or fuel container indoors where the fumes or fuel can reach an open flame, spark, or pilot light.
- Only store fuel in an approved container. Keep out of the reach of children.
- Never fill containers inside a vehicle or on a truck or trailer bed with a plastic liner. Always place the containers on the ground away from your vehicle before filling.
- Remove the machine from the truck or trailer and refuel it on the ground. If this is not possible, refuel the machine using a portable container, rather than from a fuel dispenser nozzle.

SAFETY



General Safety Procedures for Ventrac Power Units, Attachments, & Accessories



- Never remove the fuel cap or add fuel with the engine running. Allow the engine to cool before refueling.
- Never remove the fuel cap while on a slope. Only remove the fuel cap when parked on a level surface.
- Replace the fuel tank cap and the container cap securely.
- Do not overfill the fuel tank. Only fill to the bottom of the fuel neck, do not fill the fuel neck full. Overfilling of the fuel tank could result in engine flooding, fuel leakage from the tank, and/or damage to the emissions control system.
- If fuel is spilled, do not attempt to start the engine. Move the power unit away from the fuel spill and avoid creating any source of ignition until the fuel vapors have dissipated.
- If the fuel tank must be drained, it should be drained outdoors into an approved container.
- Check the fuel lines for tightness and wear on a regular basis. Tighten or repair them as needed.
- The fuel system is equipped with a shut-off valve. Shut off the fuel when transporting the machine to and from the job, when parking the machine indoors, or when servicing the fuel system.

Hydraulic Safety

- Make sure the hydraulic connections are tight and all hydraulic hoses and tubes are in good condition. Repair any leaks and replace any damaged or deteriorated hoses or tubes before starting the machine.
- Hydraulic leaks can occur under high pressure. Hydraulic leaks require special care and attention.
- Use a piece of cardboard and a magnifying glass to locate suspected hydraulic leaks.
- Keep your body and hands away from pinhole leaks or nozzles that eject high pressure hydraulic fluid. Hydraulic fluid escaping under high pressure can penetrate the skin causing serious injury, leading to severe complications and/or secondary infections if left untreated. If hydraulic fluid is injected into the skin, seek immediate medical attention no matter how minor the injury appears.
- The hydraulic system may contain stored energy. Before performing maintenance or repairs on the hydraulic system, remove any attachments, engage the parking brake, disengage the weight transfer system (if equipped), shut off the engine, and remove the ignition key. To relieve pressure on the auxiliary hydraulic system, shut off the power unit engine and move the hydraulic control lever left and right before disconnecting the auxiliary hydraulic quick couplers.

SAFETY



2120 Safety Procedures



- Do not operate the Ventrac 2120 without an attachment mounted on the front.
- Do not make rapid changes in speed or direction. Reduce vehicle speed on slopes and when making sharp turns to prevent loss of control.
- Do not operate on frozen bodies of water unless you have verified the thickness and strength of the ice and that the travel path is safe.
- The power unit hydraulic system may contain stored energy. Before performing maintenance or repairs on the auxiliary hydraulic circuit, remove attachments, engage the parking brake, disengage weight the transfer system (if equipped), shut off the engine, and remove the ignition key.
- The weight transfer spring may contain stored energy. Always disengage the weight transfer system before performing maintenance or repairs on the weight transfer system, the front hitch, or the lift (front hitch) hydraulics.

California Proposition 65



Warning

Operating, servicing, and maintaining off-road equipment can expose you to chemicals including engine exhaust, carbon monoxide, phthalates, and lead, which are known to the State of California to cause cancer and birth defects or other reproductive harm. To minimize exposure, avoid breathing exhaust, do not idle the engine except as necessary, service equipment in a well-ventilated area and wear gloves or wash your hands frequently when servicing your equipment.

For more information go to www.P65Warnings.ca.gov



Attention

It is a violation of California Public Resource Code Section 4442 to use or operate this engine on forest-covered, brush-covered, or grass-covered land unless the exhaust system is equipped with a spark arrestor maintained in effective working order. If your power unit is not equipped with a spark arrestor, contact your authorized Ventrac dealer for purchase of a spark arrestor.

Operator Safety Interlock System

The 2120 power unit is equipped with a safety interlock system. This system:

- Prevents the engine from starting unless the parking brake is engaged.
- Prevents the PTO from starting if the operator is not on the platform.
- Shuts off the PTO if the operator leaves the platform.
- Shuts off the engine if the operator leaves the platform without engaging the parking brake.
- Prevents the drive control handles from being moved from the neutral position while the parking brake is engaged.

SAFETY



2120 Safety Procedures



Testing the Safety Interlock System

⚠️ WARNING

Never operate the power unit if the safety interlock system is malfunctioning. Do not disengage or bypass any switch. Failure to heed this warning could result in injury to yourself or others, or damage to property.

⚠️ WARNING

The parking brake must be disengaged during portions of the safety interlock system test. Place wheel chocks in front and back of the wheels to prevent the power unit from moving.

ATTENTION

The daily inspection should be performed prior to initial startup for the day.

Perform the following safety interlock tests daily. Before testing, park the power unit on a level surface and place wheel chocks in front and back of the wheels. After testing is complete, engage the parking brake and remove the wheel chocks.

Test 1: with the engine running, engage the parking brake and confirm the drive control handles are locked and the power unit does not attempt to move forward or backward when pushing or pulling the handles.

Tests 2-4 test the 'Engine Start' function. For each test, turn the ignition key to the Run position (do not start the engine). As listed for each test, engage or disengage the parking brake and stand on the operator platform or step off the platform. The engine starter should or should not engage as described for each test.

	Test Number	Parking Brake Engaged	Operator Present on Platform	Engine Starts
Engine Start	2	No	Yes	No
	3	Yes	No	Yes
	4	Yes	Yes	Yes

Tests 5-8 test the 'Engine Run' function. For each test, start the power unit so the engine is running. As listed for each test, engage or disengage the parking brake and stand on the operator platform or step off the platform. The engine should continue running or stop running as described for each test.

	Test Number	Parking Brake Engaged	Operator Present on Platform	Engine Runs
Engine Run	5	Yes	Yes	Yes
	6	Yes	No	Yes
	7	No	Yes	Yes
	8	No	No	No

Tests 9-13 test the 'PTO' function. For each test, turn the ignition key to the Run position (do not start the engine). As listed for each test, place the PTO switch in the On or Off position and stand on the operator platform or step off the platform. The electric PTO clutch will make an audible noise when it engages or disengages.

	Test Number	PTO Switch	Operator Present on Platform	PTO Clutch
PTO	9	Off	Yes	Off
	10	Pull to 'On' Position	No	Off
	11	Pull to 'On' Position	Yes	On
	12	On	Yes	On (Engine will not start)
	13	On	Step Off Operator Platform	PTO Disengages

If the power unit fails any one of the safety interlock tests, the issue must be corrected before operating the power unit.

SAFETY

Safety Decals

The following safety decals must be maintained on your power unit.

Keep all safety decals legible. Remove all grease, dirt, and debris from safety decals and instructional labels. If any decals are faded, illegible, or missing, contact your dealer promptly for replacements.

When new components are installed, be sure that current safety decals are affixed to the replacement components.

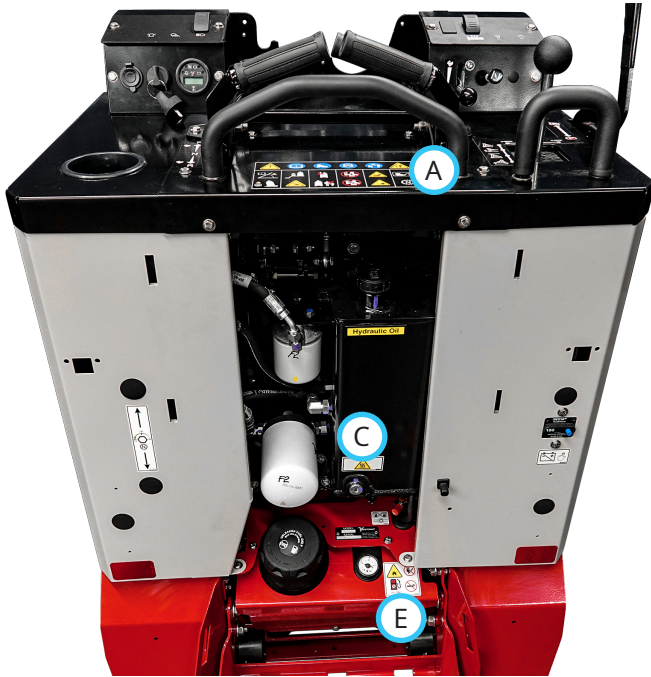

SAFETY



1. WARNING: Read operator's manual.
2. Wear personal protective gear, such as eye protection, boots, ear protection, and warm clothing suitable for weather conditions.
3. Operators must receive training prior to operating the machine.
4. Do not operate with shields or guards removed.
5. WARNING: Read slope operation instructions. Slow down when operating on slopes.
6. WARNING: Keep a safe distance from the edge of drop-offs, curbs, ditches, etc. The machine could roll over if a wheel drops over the edge or if the edge caves in.
7. Do not carry passengers. Stop the machine if someone enters the work area.
8. Do not operate while under the influence of drugs or alcohol.
9. WARNING: Hydraulic fluid is under high pressure and can penetrate skin, causing injury. Keep hands, face, and body away from pinholes or nozzles that eject hydraulic fluid under high pressure.
10. When towing or pushing the power unit, the drive pumps must be disengaged by opening the bypass valve on both pumps or damage to the hydraulic system will result.



1. WARNING: pinching or crushing hazard.
2. Stay away from moving parts.



1. Hot surface. Do not touch.

SAFETY



1. Caustic liquid/chemical burns hazard.
2. Explosion hazard - batteries produce flammable and explosive gases.
3. Do not expose the battery to arcs, sparks, or open flame. Do not smoke near batteries.
4. Keep bystanders away from the battery.
5. Wear eye protection, such as goggles or a face shield, when checking or servicing batteries.
6. Wear protective gear, such as rubber gloves and an apron, when checking or servicing batteries.



1. Warning - Explosion/fire hazard.
2. Keep away from fire, sparks, and pilot lights when refueling or storing machine and fuel.
3. Smoking is prohibited.
4. Use unleaded gasoline only with an ethanol content of 10 percent or less.

Decal	Description	Part Number	Quantity
A	Operator Safety	00.0708	1
B	Pinch Point Hazard	00.0364	1
C	Hot Surface	00.0374	6
D	Battery Hazard	00.0629	1
E	Gasoline Safety	00.0457	1

OPERATIONAL CONTROLS

Standard Control Locations

Become familiar with all the controls before you start the engine and operate the machine.

- A. Cluster Gauge
- B. Ignition Switch
- C. USB Receptacle
- D. Headlight Switch
- E. Drive Control Handles
- F. Latch (Front Control Grab Handles)
- G. Throttle Lever
- H. Choke Handle
- I. Heated Hand Grip Switch
- J. Hydraulic Control Lever
- K. Parking Brake
- L. Attachment Latch Handle
- M. Latch Handle Lock
- N. Auxiliary Hydraulic Quick Couplers
- O. Circuit Breaker and Battery Disconnect
- P. Fuel Shut-off Valve

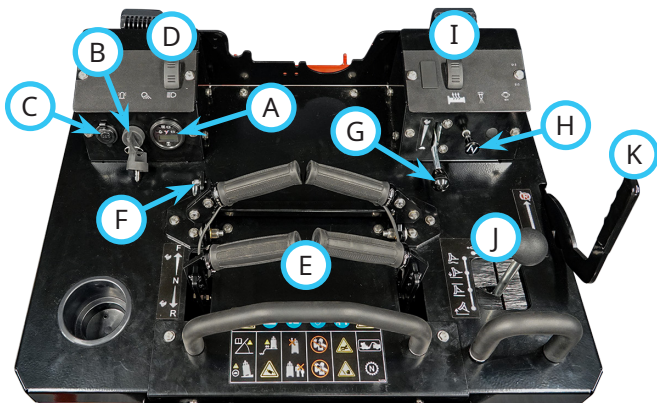

Optional Control Locations

Become familiar with all the controls before you start the engine and operate the machine.

- AA. Work Light Switch
- BB. Strobe Light Switch
- CC. PTO Switch
- DD. Brine Pump Switch
- EE. Front 12V Switch (Momentary On/Off/On)
- FF. Front 12V 4-Pin Outlet
- GG. Horn Switch
- HH. Dual Front Hydraulic Auxiliary Switch
- II. Dual Front Hydraulic Auxiliary Valve
- JJ. Weight Transfer Selector Handle
- KK. Attachment Belt Tension Spring
- LL. Backup Alarm

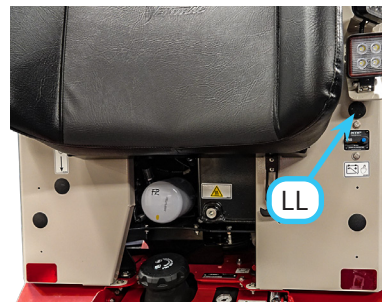
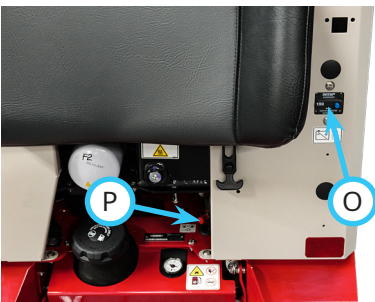
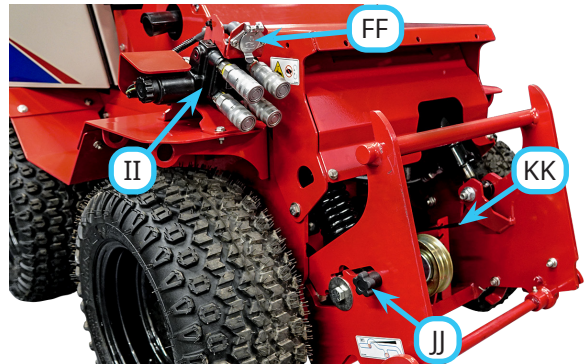
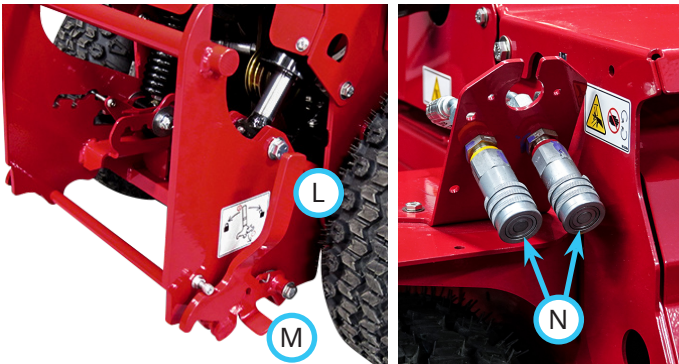
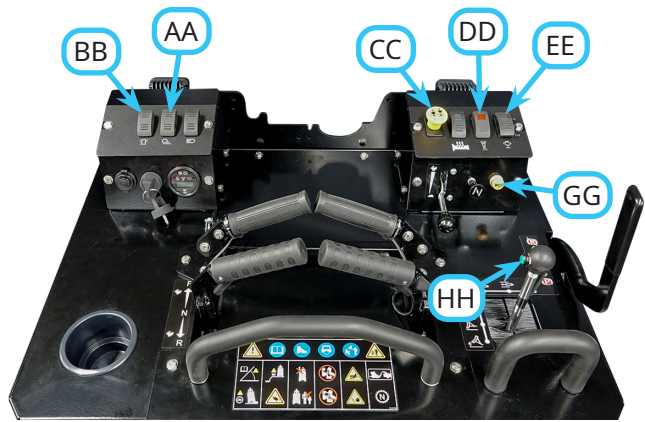

OPERATIONAL CONTROLS

Cluster Gauge (A)



1. Hour Meter
2. Low Engine Oil Pressure Warning Light
3. PTO Indicator Light
4. Parking Brake Indicator Light
5. Low Voltage Warning Light

The **hour meter** displays the accumulated time the engine has been running.

The **low engine oil pressure warning light** activates when the engine oil pressure is below safe levels. The light comes on when the ignition key is switched to the on position and stays illuminated until the engine is started and safe oil pressure develops. If this light comes on during operation, immediately shut off the engine. Do not restart the engine until the problem has been located and corrected.

The **PTO indicator light** activates when power is supplied to the PTO clutch.

The **parking brake indicator light** activates when the parking brake is engaged.

The **low voltage warning light** activates when the voltage drops to unacceptable levels. If this light comes on, shut off any unnecessary lights and accessories to reduce current draw. If voltage continues to drop, park the power unit, shut off the engine, and remove the key from the ignition. Refer to the troubleshooting section for possible problems.

Ignition Switch (B)

1. Off or Stop Position - all 12 volt power going through the key switch is off.
2. On or Run Position - engine run position, 12 volt power is sent to accessories.
3. Start Position - when the key is turned to the start position, the starter will engage.

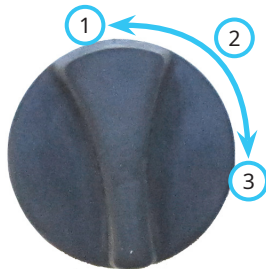

USB Receptacle (C)

The USB receptacle has two USB charging ports with a sealed cover.

Headlight Switch (D)

Pressing the front (1) of the headlight switch turns the headlights on. Pressing the back (0) of the switch turns the lights off.

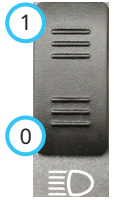

Drive Control Handles (E)

The drive control handles are used to control both the speed and direction of the power unit. The left drive handle controls the left wheels and the right drive handle controls the right wheels.

⚠ WARNING

Slow down when making sharp turns to prevent overturn accidents or loss of control.

Do not make rapid changes in speed or direction. Rapid movement of the drive control handles may result in loss of control that could result in serious injury.

To move **forward**, push both drive control handles forward an equal distance from the neutral position.

To move in **reverse**, pull both drive control handles back an equal distance from the neutral position.

The amount of forward or backward movement of the drive control handles controls the ground speed of the power unit.

To make a **turn**, slow the power unit to an appropriate speed to make the turn, then move the drive control handle toward neutral in the desired direction of turn (e.g. move the left drive control handle toward neutral to make a left turn).

To **stop**, move both drive control handles to the neutral position.

NOTE: refer to General Operation section of this manual for detailed instructions and illustrations for driving and turning the power unit.

OPERATIONAL CONTROLS

Latch (Front Control Grab Handles)

The front control grab handles have an adjustable mount that can be used to limit the travel of the drive control handles, limiting the forward speed of the power unit. Position 1 allows full forward speed, while positions 2 - 4 progressively limit the forward travel of the drive control handles.

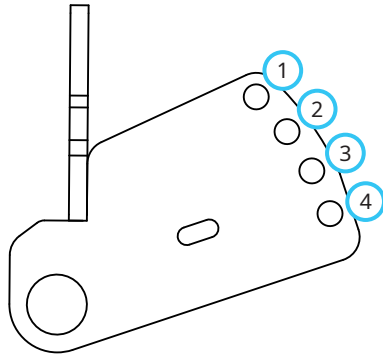

Pull out on the latch pin and move the grab handles to the desired position. Release the latch pin to lock the grab handles in place.

Throttle Lever (G)

Moving the throttle lever forward toward the fast position (1) increases the engine Revolutions Per Minute (RPM). Moving the throttle lever backward toward the slow position (2) decreases the engine RPM.



Choke Handle (H)

Pull the choke handle out to aid in starting a cold engine. Push the choke handle in for operation.

Heated Hand Grip Switch (I)

The heated hand grip switch turns on the heat for the hand grips on the drive control handles and the front grab bars. Pressing the front (1) of the switch turns the heat on high. Pressing the rear (2) turns the heat on low. Return the switch to the middle position to turn the heat off.



Hydraulic Control Handle (J)

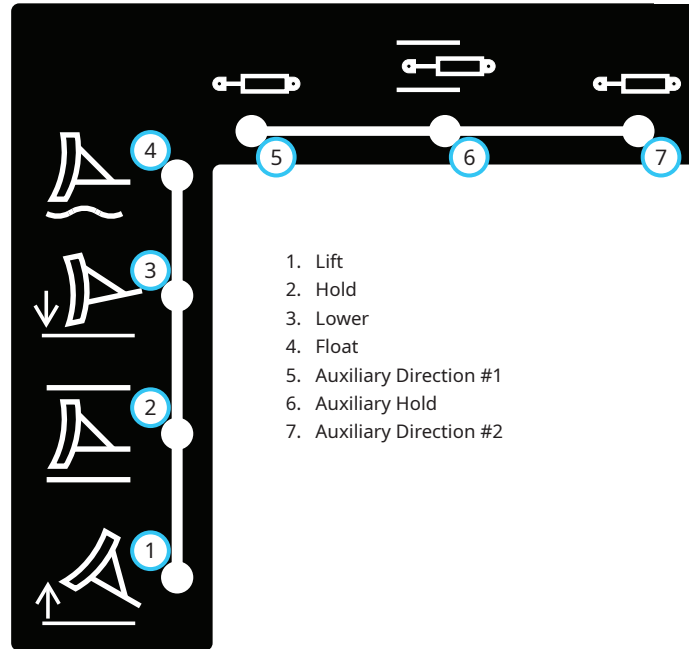

1. Lift
2. Hold
3. Lower
4. Float
5. Auxiliary Direction #1
6. Auxiliary Hold
7. Auxiliary Direction #2

The hydraulic control lever controls the lift of the power unit's front hitch and the auxiliary hydraulic circuit.

Hold is the default position of the hydraulic control lever. It holds the position of the front hitch and the auxiliary circuit.

Pulling the lever back raises the power unit's front hitch. Pushing the lever forward lowers the power unit's front hitch. Float position is attained by pushing the lever forward until the float detent locks the lever in place.

Moving the lever to the left or right controls the functions of attachments that require the auxiliary hydraulic circuit (e.g. angles snow plow right or left).

Parking Brake (K)



1. Parking Brake Disengaged
2. Parking Brake Engaged (Set)

When parking the power unit, always engage the parking brake to prevent accidental movement of the machine.

To engage the parking brake, pull the brake handle back toward the operator.

To disengage the parking brake, push the brake handle forward.

If the operator leaves the platform without engaging the parking brake, the engine will shut off.

OPERATIONAL CONTROLS

Attachment Latch Handle (L)

The attachment latch handle secures the attachment to the power unit's hitch.

Rotate the latch handle backward to disengage the latch tab when attaching or detaching Ventrac attachments.

Rotate the latch handle forward to lock the attachment frame to the front hitch. Ensure the latch tab is engaged in the attachment lower hitch plate and the latch handle lock is in place.

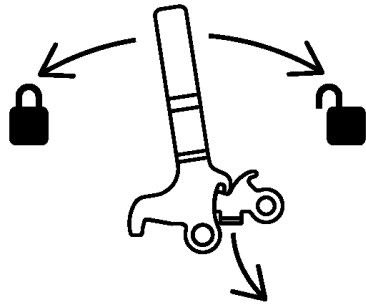

Latch Handle Lock (M)

The latch handle lock prevents the accidental release of the attachment latch handle. To release the attachment latch handle, rotate the latch handle lock down away from the latch handle.

Auxiliary Hydraulic Quick Couplers (N)

The two couplers are a part of the auxiliary hydraulic circuit and are used with an attachment that requires hydraulics (e.g. to angle a snow plow or rotate the discharge on a snow blower).

Circuit Breaker and Battery Disconnect (O)

The circuit breaker/battery disconnect switch controls power to the entire electrical system.

Pushing the button (0) on the switch disables the electrical system, allowing electrical components to be serviced.

When the button on the switch is pushed to disengage electrical power, a reset lever (1) drops down from the switch body. Lift up on the reset lever to restore electrical power.



- 0. Push to disengage power
- 1. Lift to restore power

Fuel Shut-off Valve (P)

The fuel shut-off valve controls the flow of fuel to the power unit engine. Turning the valve counterclockwise (1) to the stop allows fuel to flow to the engine.

Turning the valve clockwise (0) to the stop shuts off the fuel flow to prevent fuel leakage when changing fuel filters or servicing the fuel system. Turn off the fuel shut-off valve when transporting the power unit on a truck or trailer and when parking the power unit indoors.

To prevent fuel leakage when changing fuel filters or servicing the fuel system, turn off the fuel shut-off valve, start the engine, and allow to run until the engine stops.

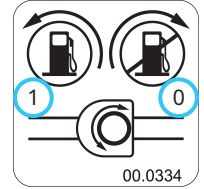

- 0. Fuel Off
- 1. Fuel On

Rear Work Light Switch (AA)

Pressing the front (1) of the rear work light switch turns the rear work lights on. Pressing the back (0) of the switch turns the rear work lights off.

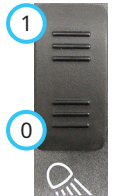

Strobe Light Switch (BB)

Depressing the top (1) of the strobe light switch turns on the strobe light. Depressing the bottom (0) of the switch turns the strobe light off.

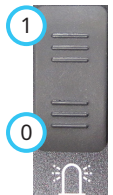

Power Take Off (PTO) Switch (CC)

Pulling up on the PTO switch engages the electric clutch to provide power to the front attachment.

Pushing down on the PTO switch disengages the electric clutch and applies the clutch brake to stop the attachment. NOTE: the engine will shut off if the operator leaves the platform with the PTO engaged. In order to restart the engine, the PTO switch must be turned off.



- 0. PTO Off
- 1. PTO On

Brine Pump Switch (DD)

Pressing the front (1) of the brine pump switch turns on electrical power to the brine pump. Pressing the back (0) of the switch turns the pump off.

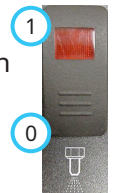

OPERATIONAL CONTROLS

Front 12V Switch and 4-Pin Outlet (EE, FF)

The 4-pin socket provides electrical power to attachments that are equipped with electrical controls. (e.g. broom rotation actuator)

The switch controls the electrical power to the front 4-pin socket. Pressing the top (1) or bottom (2) portion of the momentary on/off/momentary on switch turns on electrical power to the 4-pin socket. Releasing the switch turns off electrical power.



Horn Switch (GG)

Press the horn switch to sound the signal horn. The horn will sound until the horn switch is released.



Dual Front Hydraulic Auxiliary Switch (HH)

The optional switch handle is part of the dual front hydraulic auxiliary kit and is used to select which set of quick couplers is controlled by the left or right movement of the hydraulic control lever. The hydraulic control lever operates the quick couplers with the red and yellow indicators until the button on the handle is pressed. Press and hold the button to switch control to the quick couplers with the white and black indicators. Release the button to return to normal operation.

Dual Front Hydraulic Auxiliary Valve (II)

The dual front hydraulic auxiliary valve is used with attachments that are equipped with four hydraulic hoses. The valve uses a switch on the hydraulic control lever to operate the desired set of quick couplers.

Weight Transfer Selector Handle (JJ)

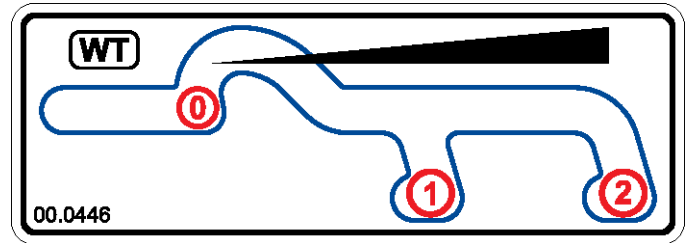

The weight transfer system transfers weight from the attachment to the front wheels of the power unit. Transferring weight from the attachment to the power unit increases traction, aids in lifting the attachment, and lessens the attachment resistance when in contact with the ground and operating with hitch in float.

The operator can select different transfer rates by selecting one of the three positions from no weight transfer (0) to maximum weight transfer (2).

Set weight transfer to (0) when attaching or detaching any attachment.

The weight transfer can only be adjusted with the front hitch fully raised.

Attachment Belt Tension Spring (KK)

The belt tension spring places tension on the attachment drive belt. The spring bracket has several hook positions to allow adjustments in belt tension.

Backup Alarm (LL)

The backup alarm emits an intermittent signal when the power unit is operated in reverse to alert nearby persons that the power unit is backing up.

GENERAL OPERATION

Daily Inspection

⚠ WARNING

Always engage the parking brake, shut off the power unit engine, remove the ignition key, and ensure that all moving parts have come to a complete stop before inspecting the components, or attempting any repair or adjustment.

1. Park the machine on a level surface, with the engine shut off and all fluids cold.
2. Perform a visual inspection of the power unit. Look for loose or missing hardware, damaged components, or signs of wear.
3. Inspect the battery, the electrical connections, and the lights.
4. Ensure the parking brake is properly adjusted.
5. Inspect the hydraulic hoses and the hydraulic fittings to ensure tight, leak free connections.
6. Inspect the fuel lines to ensure tight, leak-free connections.
7. Inspect the belts for damage or excessive wear. Refer to the Belt Inspection section of this manual.
8. Inspect the engine oil level, the hydraulic oil level, and the fuel level. Add fluid or service as required.
9. Ensure the air cleaner and engine compartment are clean.
10. Check the tires for proper inflation.
11. Test the operator safety interlock system.

Starting the Engine

⚠ CAUTION

Use of ether or starting fluids may cause engine damage and/or personal injury. Do not use ether or starting fluids to aid in starting the engine.

The 2120 is equipped with an interlock system for operator safety. The safety interlock system requires the parking brake to be engaged in order for the engine to start.

1. Turn the fuel shut-off valve to the On position.
2. Set the battery disconnect switch to the On position.
3. Pull the choke handle out to the choke on or start position. Choke may not be required if the engine is already warm.
4. Move the throttle lever to the fast idle position.

ATTENTION

Do not run the electric starter continuously for more than five seconds. If the engine does not start in this time, wait 1 minute and try again.

5. Turn the ignition key clockwise to the start position and hold to engage the starter. Release the key when the engine starts. NOTE: if the engine fails to start, refer to the troubleshooting section.
6. After starting the engine, gradually push the choke handle back in to the run position.

ATTENTION

Allow time for the hydraulic oil to circulate before operating the power unit. Failure to allow adequate warm up time may result in severe damage to the hydraulic system. Warm up time is increased in colder weather.

7. The engine and hydraulic oil must be warmed to operating temperature before applying load. Allow the engine to run at half throttle for 3 to 5 minutes.

Forward and Reverse

Verify the intended path is safe and free from obstacles and disengage the parking brake.

Power unit movement is controlled by moving the left and right drive control levers in the desired direction of travel. Push the drive control levers forward to move the power unit in the forward direction.

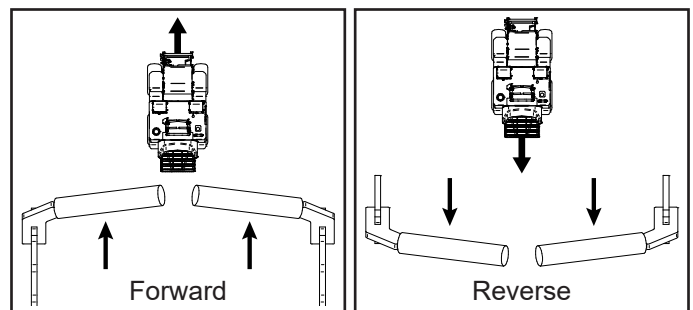

Pull the drive control levers backward to make the power unit move in the reverse direction. Changing the amount the drive control levers are moved instantly changes the ground speed of the power unit. Moving the drive control levers one half stroke will result in approximately one half of the maximum ground speed. Moving the levers to the end of the stroke will result in maximum ground speed.

GENERAL OPERATION

Turning (Left, Right, and Turn in Place)

Turning is accomplished by varying the amount of stroke between the right and left drive control handles. If the drive control handles are not moved the same distance from neutral, the power unit will turn in the direction of the lever closest to the neutral position.

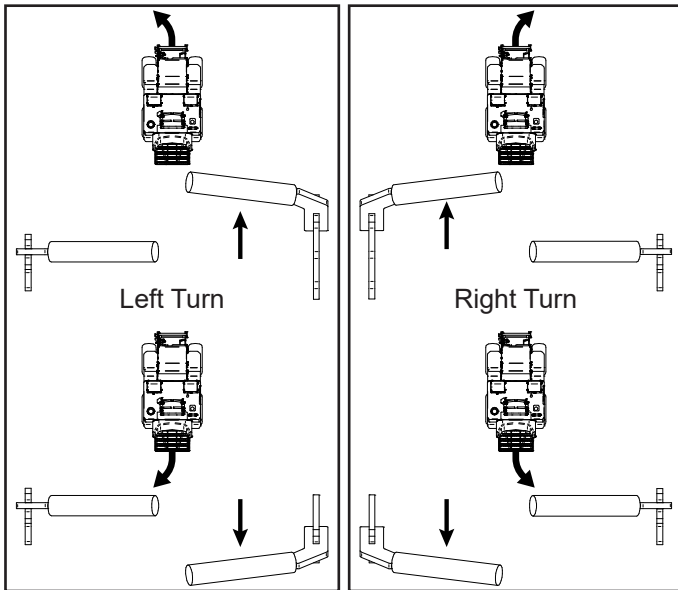

The greater the stroke variance between the left and right drive control levers, the sharper the power unit will turn.

To turn in place, move one lever forward from neutral and the other lever backward from neutral.

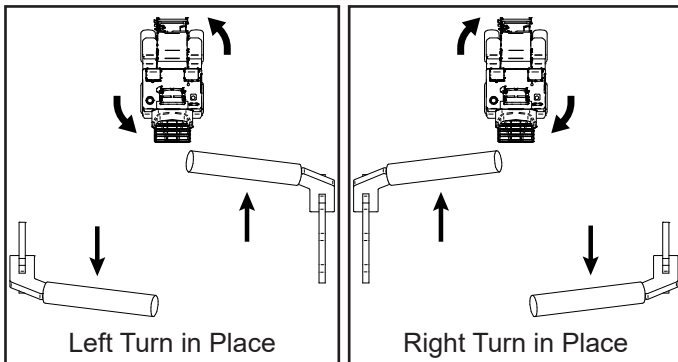

Stopping the Power Unit

To slow or stop the power unit, move the drive control levers in the opposite direction that you are traveling. Return the drive control levers to the neutral position to make a complete stop.

If in the case of an emergency, the power unit cannot be stopped with the drive control levers, pull back on the parking brake handle to engage the parking brake.

CAUTION

If the parking brake is engaged while the power unit is moving, the power unit will come to an abrupt stop.

Shutting Off the Engine

1. Park the power unit on a level surface and engage the parking brake.
2. Move the throttle lever to the slow idle position.
3. Allow the engine to idle for one minute.

ATTENTION

Engine damage can occur from run-on or after-burning if the engine is stopped suddenly from high speed loaded operation. Allow the engine to idle for one minute before shutting off the engine.

4. Turn the ignition key to the Off position and remove the key from the ignition switch.
5. When parking the power unit at the end of the day, push the button on the battery disconnect switch to disengage power and turn the fuel shut-off valve to the Off position.

GENERAL OPERATION

Attaching

1. Align the power unit squarely with the attachment and drive forward slowly until the power unit hitch is close to the attachment frame.
2. Lower the power unit hitch until the hitch tabs (A) are below the top latch plate(s) on the attachment hitch frame.

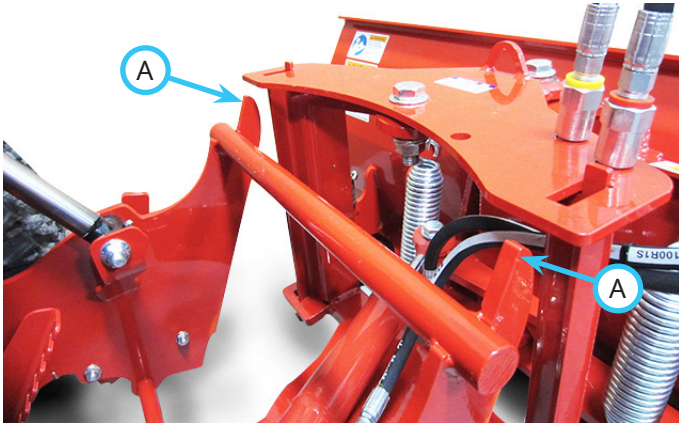

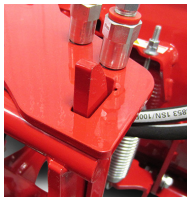
3. Drive forward slowly until the power unit hitch tabs are aligned with the hitch point slots in the attachment hitch frame.
 4. Raise the power unit hitch to engage the tabs in the hitch point slots. Continue to raise the hitch until the attachment is lifted just off the ground.
- 
5. Engage the parking brake and shut off the power unit engine.
 6. Rotate the attachment latch handle forward to the latched position. Make sure the latch tabs (B) are engaged in the lower latch plate, and the latch handle lock (C) is engaged to prevent accidental disengagement of the latch handle.

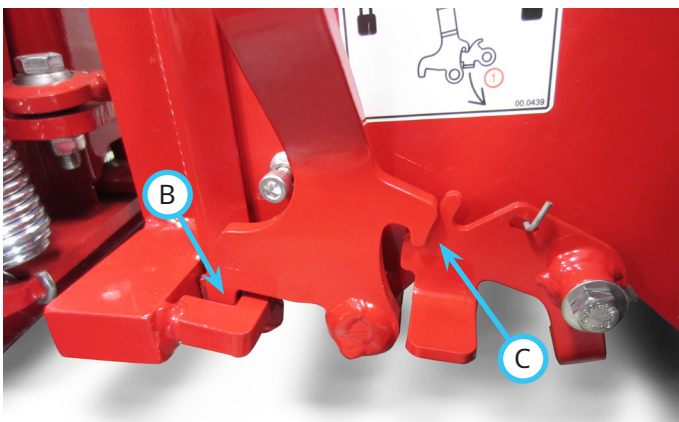

7. Place the attachment belt* onto the PTO drive pulley on the power unit. Ensure the belt is properly seated in each pulley.

8. Engage the drive belt tension spring (D) on the power unit to apply tension to the attachment belt.

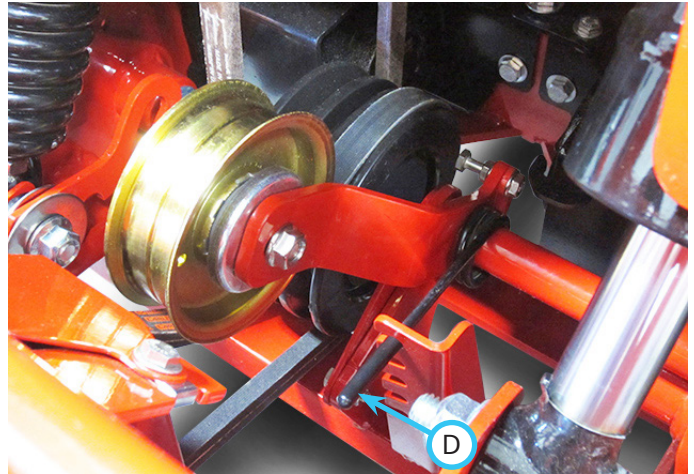

9. Wipe hose ends* clean and connect to the power unit's hydraulic quick couplers. Connect the hoses and quick couplers so the colored indicator washers are paired together.
10. Connect the electric actuator plug* to the matching socket on the power unit.

*Applies only if the attachment is equipped.

GENERAL OPERATION

Detaching

1. Park the power unit on a level surface and engage the parking brake.
2. Lower the attachment to the ground.
3. Shut off power unit engine.
4. Disconnect the electric actuator plug* from the socket on the power unit.
5. Move the hydraulic control lever left and right to release pressure from the auxiliary hydraulic circuit and disconnect the hydraulic quick couplers* from the power unit. Store hose ends in the attachment frame holes.
6. Disengage the drive belt tension spring on the power unit.
7. Remove the attachment belt from the PTO drive pulley of the power unit.
8. Disengage the latch handle lock and rotate the attachment latch handle back to unlatch from the lower latch plate on the attachment.
9. Restart the power unit and lower the power unit hitch to clear the top latch plate on the attachment hitch frame, while slowly backing away from the attachment.

*Applies only if the attachment is equipped.

Operating Attachments

Refer to the operator's manual for each attachment for the proper use and operation of the particular attachment. The operator must read and understand the operator's manual prior to using an attachment.

Front Hitch

The front hitch is used to secure attachments to the power unit and to raise and lower the attachment. The front hitch is controlled by the hydraulic control lever. Pull the lever back to raise the attachment and push the lever forward to lower the attachment. Push the lever forward until the float detent engages and holds the lever in place to operate in float.

Front Auxiliary Couplers

CAUTION

Dirt and other debris in the hydraulic system can cause damage to the system. Wipe the mating parts of the couplers clean before connecting.

If the attachment requires auxiliary hydraulics, couple the attachment hoses with the front auxiliary couplers. Insert the end of the attachment hose into the power unit coupler and push until it locks in place.

To disconnect the couplers, pull back on the collar on the power unit coupler to release the attachment hose.

The couplers that the hoses are attached to will affect the direction the hydraulic control lever is moved to control the action of the attachment. Connect the hoses and quick couplers so the colored indicator washers are paired together (red to red, yellow to yellow).

The auxiliary couplers are controlled by moving the hydraulic control lever to the left or right.

NOTE: pressure buildup in the attachment hoses and the power unit couplers may occur, causing difficult installation of hoses. If hoses do not easily connect, try one or both of the following steps.

1. To release the pressure from power unit couplers, turn off the engine and move the hydraulic control lever left and right to release pressure in the power unit's hydraulic circuit.
2. To release pressure in the attachment hose, loosen one of the hose ends and retighten after pressure is released.



WARNING

Hydraulic fluid is under high pressure and can penetrate skin causing injury. Keep your hands, face, and body away from pinholes or nozzles that can eject hydraulic fluid under high pressure.

GENERAL OPERATION

Weight Transfer (Optional Accessory)

The weight transfer system transfers weight from the attachment to the front wheels of the power unit. Transferring weight from the attachment to the power unit increases traction, aids in lifting the attachment, and lessens the attachment resistance when in contact with the ground when operating with the hitch in float.

The operator can select different transfer rates by selecting one of the three positions from no weight transfer (0) to maximum weight transfer (2). Set the weight transfer to (0) when attaching or detaching any attachment.

To set the weight transfer, raise the front hitch to its maximum height and move the weight transfer selector handle to the desired position.

NOTE: if the adjustment knob will not easily move positions, the weight transfer spring may need to be adjusted. Refer to the service section for adjustment instructions.

Selecting the proper amount of weight transfer depends on the attachment, conditions, and operator preference. A lightweight attachment will not operate in float with full weight transfer on. A heavy attachment may be difficult to lift and control without weight transfer engaged.

Front 12 Volt 4-Pin Outlet (Optional Accessory)

Certain attachments or accessories require a 12 volt auxiliary outlet. Plug the attachment's 12 volt power cord into the 4-pin outlet. The actions of the front 12 volt outlet are controlled by a momentary on/off/on switch on the right dash panel.

Operator Cushion Height Adjustment

The operator cushion has five different height settings. To adjust the operator cushion height:

1. Remove the four bolts (A) that fasten both sides of the cushion mount plate to the bracket.
2. Move the operator cushion up or down to the desired position.
3. Reinstall the bolts and torque to 9 Nm (79 in-lbs).



Towing or Pushing the Power Unit

ATTENTION

Avoid damage to your power unit! Before towing, read and understand the information below. Severe damage will occur to the unit if the proper towing procedure is not followed.

Failure to open the bypass valves on both pumps when towing or pushing the power unit will result in damage to the hydraulic drive system.

1. Place the drive control handles in the neutral position and engage the parking brake.
2. Shut off the engine and remove the ignition key.
3. Remove the plastic plugs (A) from the left rear tower panel to access the bypass valves.
4. Open the bypass valve on both pumps by turning them counterclockwise 1/4 to 1/2 turn. This allows the hydraulic oil to flow past the pump so the wheels can turn.



CAUTION

When the pump bypass valves are open and the parking brake is released, the power unit can free-wheel. Do not attempt to tow or push the power unit on steep slopes. Use extreme caution and move the power unit slowly when towing or pushing.

5. Release the parking brake and push or tow the power unit slowly to the desired location. Do not exceed 5 km/h (3 mph). NOTE: the steering will not function when towing or pushing the power unit.
6. Engage the parking brake.
7. Close the bypass valve on both pumps. Torque to 12.5 - 14.5 Nm (110 - 130 in-lbs).
8. Reinstall the plastic plugs into the holes in the left rear tower panel.

SERVICE

⚠ WARNING

Always engage the parking brake, shut off the power unit engine, remove the ignition key, and ensure that all moving parts have come to a complete stop before inspecting the components, or attempting any repair or adjustment.

ATTENTION

Ventrac recommends that service be performed by a qualified technician. If you are unsure how to perform the service procedure(s), contact your Ventrac dealer.

ATTENTION

If any component requires replacement, use only original Ventrac replacement parts.

Service and General Maintenance

Proper and timely service of this power unit is critical to keep the power unit in a safe and reliable operating condition. Follow the maintenance schedule at the end of the service section. For convenience, a frequent service guide decal and a quick reference decal have been placed on the inside of the right door.

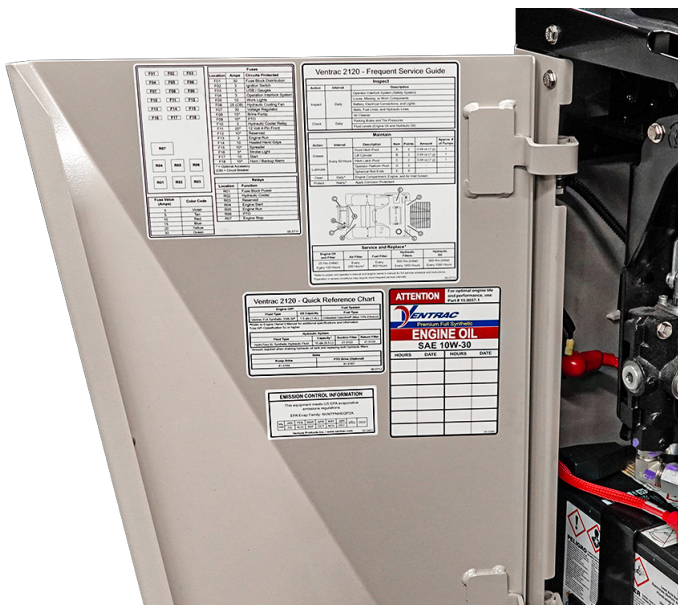

Cleaning and Appearance Care

For best results, and to maintain the finish of the power unit, clean or wash the power unit to remove dirt, salt deposits, and ice or snow accumulations.

ATTENTION

To maintain the finish of the power unit, thoroughly wash the equipment after each use to remove any corrosive agents (e.g. salt). Failure to clean the equipment may result in corrosion of (including but not limited to) steel, aluminum, and electrical components. Equipment that will experience repeated exposure to corrosive agents should be pretreated with a corrosion preventative.

⚠ CAUTION

If the engine has been running, it must be allowed to cool in order to prevent damage to the block and the exhaust manifold.

Do not direct high pressure water at the engine, air cleaner, muffler, hydraulic oil cooler, or any electrical components.

Allow the power unit and all components to cool before washing. Refer to the specific service section for proper cleaning techniques for the engine and engine compartment. Use mild soap and water to clean the power unit. Harsh chemical cleaners could cause damage to the finish or the components.

After cleaning, use touch up paint to repair any chips or scratches in the finish.

SERVICE

Service Access Points

Throughout the service chapter, various access points are referred to. The following list and images identify shields and covers that may need to be removed or opened during service.



- 1. Operator cushion
- 2. Left door
- 3. Left engine cover
- 4. Accessory mount / shield frame



- 5. Right door
- 6. Right engine cover
- 7. PTO drive cover
- 8. PTO belt cover (under the muffler)

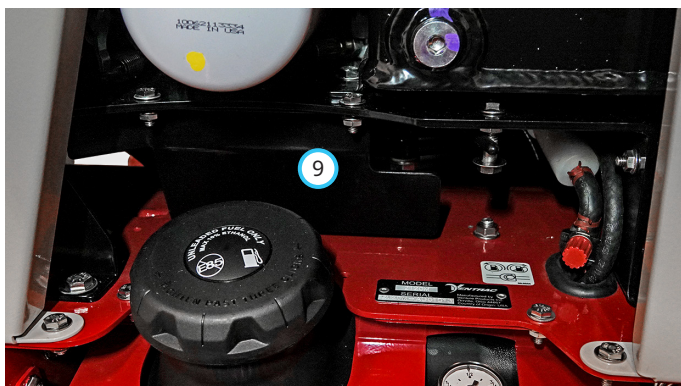

- 9. Pump belt drive cover

Lubrication Locations

Lubrication is required at the following locations. Refer to the maintenance schedule for service intervals and the amount of grease. Refer to the fluid capacities and specifications section for the grease type.

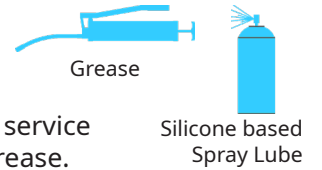

Grease the lift cylinder lower end, the front hitch pivots, and the attachment latch handle pivots.

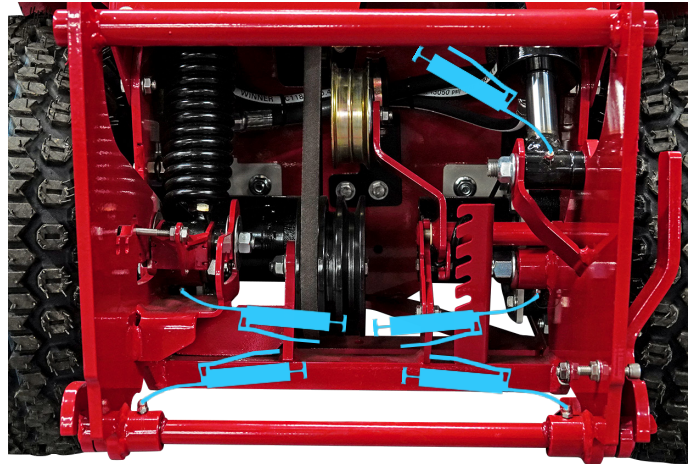

Remove the left engine shield and grease the lift cylinder upper end.

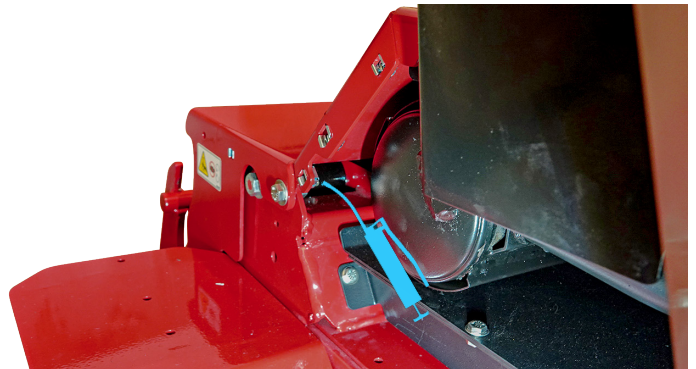

Lubricate the operator platform pivots.

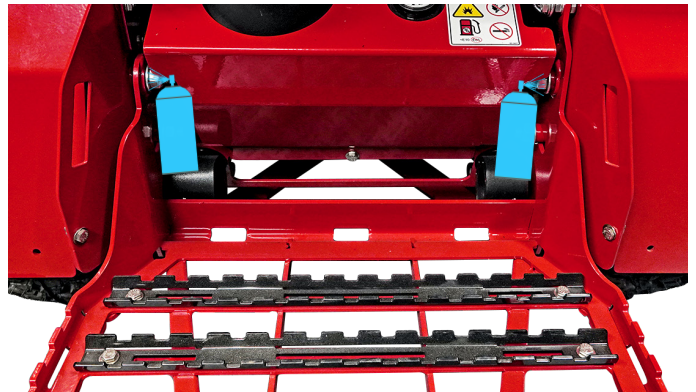

SERVICE

Lubricate the spherical rod ends on the valve control links.

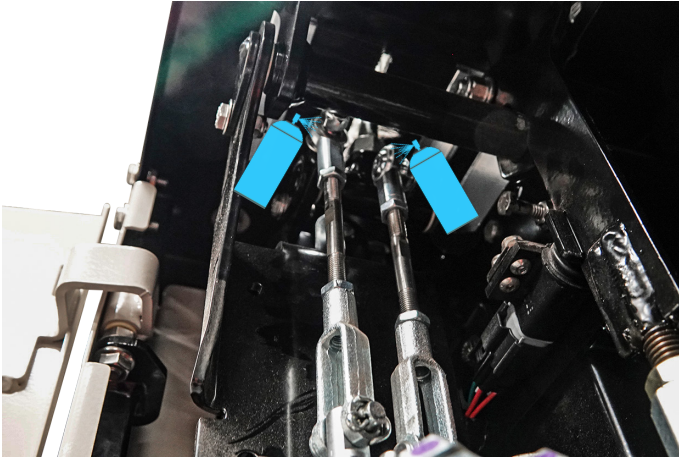

Lubricate the spherical rod ends on the pump control links.

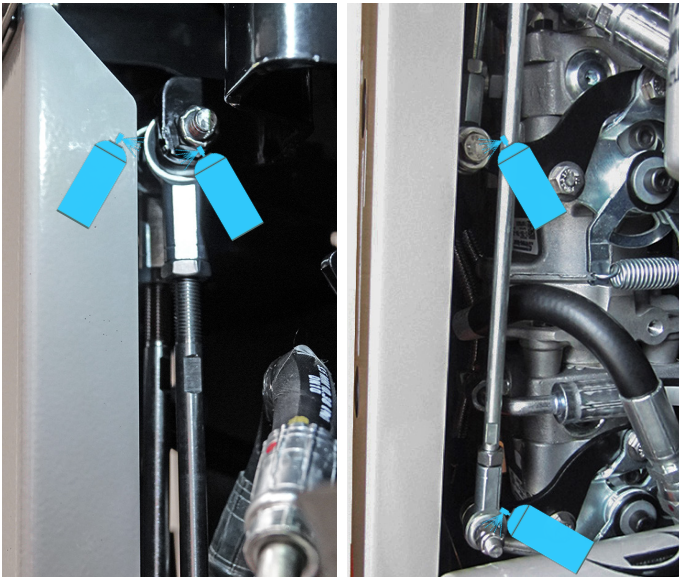

Checking the Hydraulic Oil Level

Check the hydraulic oil level when the hydraulic system is cold, prior to operating the power unit. If the hydraulic system is warm, allow one hour for the hydraulic system to cool before checking the oil level. Checking the oil level when the hydraulic system is warm will produce an inaccurate oil level reading.

ATTENTION

After connecting a new attachment or kit that runs off the power unit's hydraulic system, run the attachment or kit through a complete cycle, then stop and check the hydraulic oil level.

1. Park the power unit on a level surface.
2. Fully raise the front hitch.
3. Engage the parking brake and shut off the engine.
4. Remove the key from the ignition switch and allow time for the hydraulic system to cool.
5. Remove the operator cushion from the rear panels of the power unit.
6. Remove the dipstick (A) from the hydraulic oil tank and wipe with a clean cloth.
7. Set the dipstick back in place without threading in.
8. Remove the dipstick and check the oil level. The level should be between the two notches on the dipstick.
9. If the hydraulic oil level is low, add Ventrac HydroTorq XL synthetic hydraulic oil until the proper level is reached.
10. Reinstall the dipstick into the hydraulic oil tank.
11. Place the operator cushion back on the power unit.



SERVICE

Changing the Hydraulic Oil and Filters

1. Drive the front wheels of the power unit onto 2 x 4 blocks to raise the front of the power unit 4 - 5 cm (1-1/2 - 2 inches).
2. Fully raise the front hitch.
3. Shut off the engine and allow time for the hydraulic system to cool.
4. Remove the operator cushion from the rear panels of the power unit.
5. Place a drain pan (minimum 11.5 liter / 12 quart) beneath the operator platform.
6. Using a funnel with a hose attached and routed down through the operator platform to the drain pan, hold the funnel underneath the drain port (A) on the hydraulic oil tank.

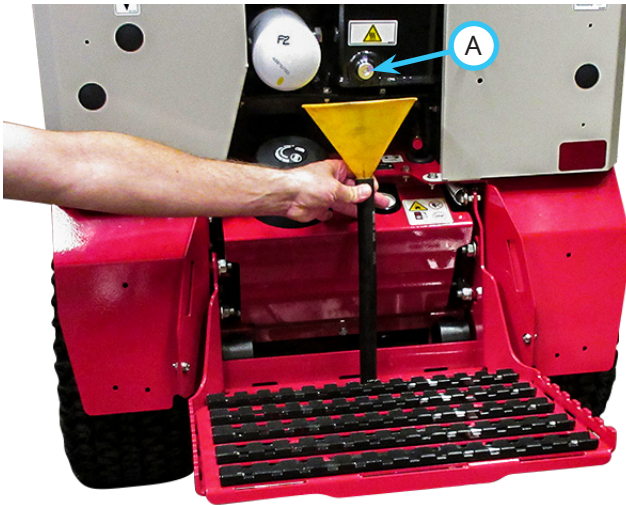

7. Remove the drain plug from the hydraulic oil tank and allow the hydraulic oil to drain from the system. Loosen the dipstick on the hydraulic oil tank to allow venting.
8. Clean the drain plug, reinstall into the hydraulic oil tank, and torque to 42 Nm (31 ft-lbs).
9. Clean the hydraulic filters and filter heads.
10. Place a rag under the large filter and over the fuel tank area to soak up spilled oil.

11. Use a strap type filter wrench to unscrew both the large and small hydraulic filters (B) from the filter heads. After removal, drain the filters into the drain pan.

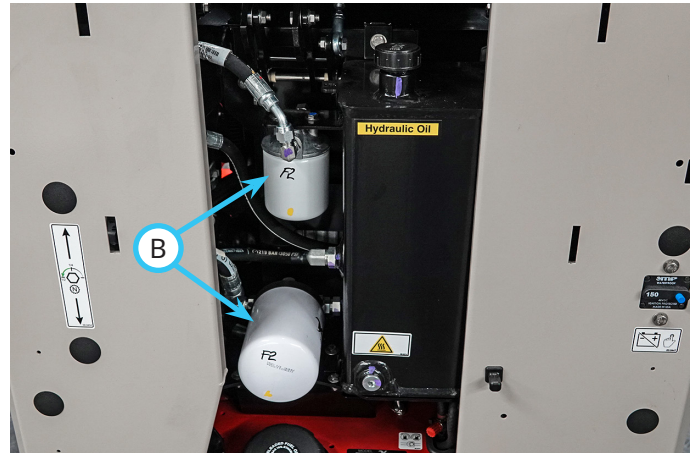

12. Ensure the filter mounting surfaces are clean.
13. Apply a thin film of clean oil to the gasket of the new large filter and screw the filter onto the filter head until the gasket makes contact with the mounting surface. Tighten the filter an additional 3/4 of a turn (may require using a strap type filter wrench).
14. Apply a thin film of clean oil to the gasket of the new small filter and screw the filter on to the filter head until the gasket makes contact with the mounting surface. Tighten the filter an additional 1 turn (may require using a strap type filter wrench).
15. Clean up any spilled oil and dispose of the used oil and filters in accordance with local laws.

ATTENTION

Oil is hazardous to the environment. Drain the oil into an approved container and dispose of the used oil in accordance with local laws.

16. Add Ventrac HydroTorq XL synthetic hydraulic oil to the hydraulic oil tank until the proper level is reached.
17. Start the power unit and let it run for several minutes at low idle engine speed. Drive the power unit back and forth in forward and reverse for several cycles.
18. Shut off the power unit engine and engage the parking brake. Allow the power unit to sit for a minimum of five minutes.
19. Check the hydraulic oil level and add Ventrac HydroTorq XL synthetic hydraulic oil, if necessary.
20. Place the operator cushion back on the power unit.

SERVICE

Servicing the Hydraulic Oil Cooler

1. Open the left door and brush any dirt or debris from the grill on the oil cooler fan (A).

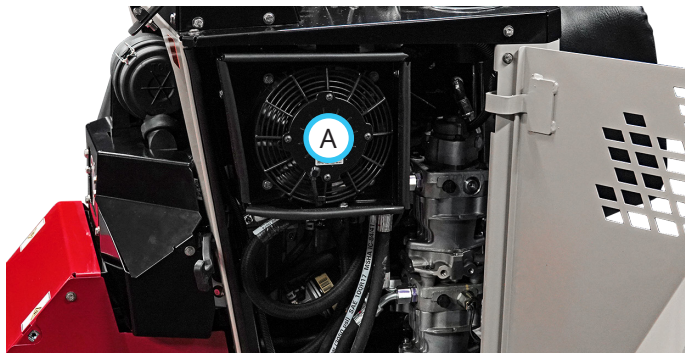

2. Remove the operator cushion to access the back of the cooler and use low pressure air to blow back through the oil cooler to remove accumulated dust or debris from the oil cooler fins.

Checking the Engine Oil Level

ATTENTION

Failure to check the engine oil regularly could lead to serious damage to your engine, if the engine is run with an incorrect oil level.

- Check the engine oil level with the power unit sitting on a level surface and with the engine shut off and the oil cold.
- Keep the oil level between the **Full** and **Add** marks.
- Do not add oil with the engine running.

1. If the power unit has been running, allow the engine and oil to cool.
2. Open the right door.
3. Remove the oil dipstick (A) from the engine and wipe with a clean cloth.

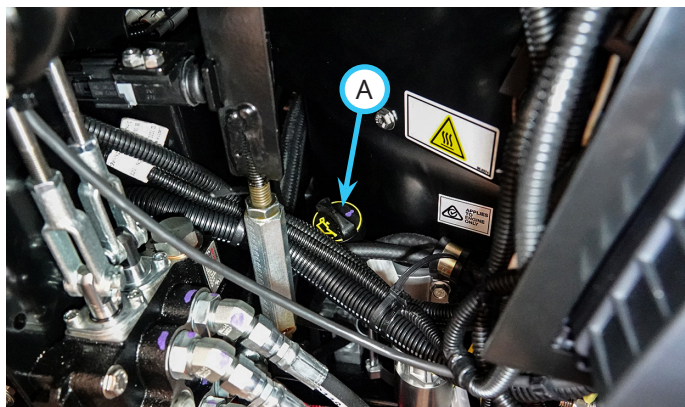

4. Insert the dipstick back into the engine without threading it in and remove again.
5. Check the oil level. The level should be between the Full (B) and Add (C) marks on the dipstick.



6. If the oil level is low, add small amounts of engine oil to bring the oil level no higher than the Full (B) mark on the dipstick.
7. If the oil level is above the Full (B) mark, drain some engine oil to achieve the proper level.
8. Reinstall the dipstick and close the right door.

SERVICE

Changing the Engine Oil and Filter

⚠ CAUTION

Contact with engine oil can irritate your skin. Wear protective gloves when working with engine oil. If you come in contact with engine oil, wash it off your skin immediately.

ATTENTION

Oil is hazardous to the environment. Drain engine oil into an approved container. Dispose of used engine oil in accordance with local laws.

1. Start the power unit engine and allow it to run until the engine reaches operating temperature.
2. Park the power unit on a level surface.
3. Shut off the engine and allow the engine to cool from hot to warm.

⚠ WARNING

Hot engine oil can cause severe burns. Allow the engine temperature to drop from hot to warm before draining the engine oil.

4. Open the left and right doors.
5. Place a drain pan on the operator platform.
6. Pull the engine oil drain hose (A) out of the rear of the tower frame so the end is above the drain pan.



7. Remove the drain cap from the drain hose and drain the engine oil into the pan while the oil is warm.

8. Place a small drain pan or shop towels under the oil filter (B) and turn the filter counterclockwise to remove.
9. Wiper the filter mounting surface with a clean cloth.
10. Apply a thin film of clean oil to the gasket of the new oil filter.
11. Screw the new filter onto the engine until the gasket makes contact with the mounting surface. Tighten the filter 1/2 to 3/4 turn more by hand.
12. Clean the end of the oil drain hose and make sure the O-ring is in place on the end of the hose fitting. Reinstall the drain cap and torque to 47 Nm (35 ft-lbs).
13. Remove the oil dipstick from the engine.
14. Add oil to the engine. Refer to the Engine Owner's Manual for proper oil specifications and capacity.

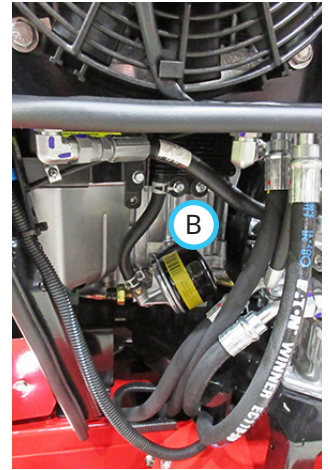

ATTENTION

For optimal engine life and performance, use Ventrac full synthetic engine oil (Part Number 15.0037-1).

15. Install the oil dipstick and wipe up any oil spills.
16. Start the power unit and let it run at low idle engine speed for approximately two to three minutes.
17. Shut off the engine and remove the ignition key.
18. Check for leaks around the oil filter. If any leaks are evident, the filter may need tightened further, or the filter may need to be removed, the gasket and filter mount cleaned, and the filter reinstalled.
19. Check the engine oil level after allowing the engine to cool for approximately two minutes and add oil if necessary.
20. Close the left and right doors.

SERVICE

Air Filter Service and Replacement

ATTENTION

When the air filter element is removed, an opening is created to the internal parts of the engine. Be sure nothing falls into the canister that could make its way into the engine. Have the new filter element ready to install immediately after removing the old filter element.

Improper service to the engine air filter can result in severe engine damage.

- Never run the engine without a proper air filter installed.
- Never wash or clean the paper filter element.

1. If the power unit has been running, allow the engine to cool.
2. Release both latches (A) on the engine air filter assembly, unhook the latches from the main filter housing, and remove the filter cap (B).

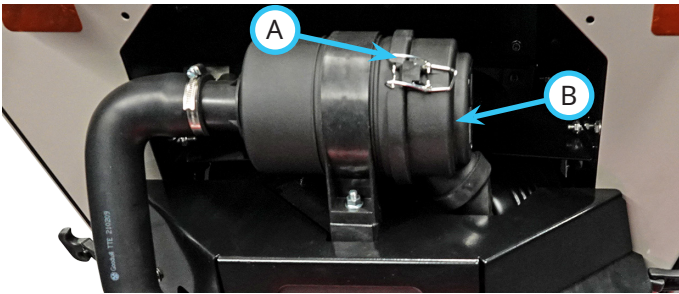

3. Remove and discard the filter element (C).

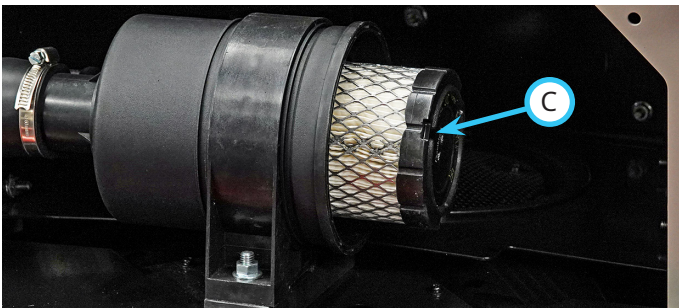

4. Install the new air filter element.
5. Reinstall the filter cap and fasten both latches.

Filling the Fuel Tank

⚠ DANGER

Fuel is flammable and explosive. Follow all safety instructions in the Fuel Safety section and in the Engine Owner's Manual.

⚠ WARNING

Long term exposure to fuel vapors can cause serious injury or illness. Avoid prolonged breathing of fuel vapors.

If fuel is spilled on your skin or clothing, change your clothing and wash the affected area immediately.

ATTENTION

Improper fuel can damage your engine. Only use fuel that meets the fuel grade and specifications listed in the Engine Owner's Manual.

1. Park the power unit on a level surface.
2. If the power unit has been running, allow the engine to cool.
3. Wipe the fuel cap (A) clean to prevent any dirt from falling into the fuel tank and remove the fuel cap.

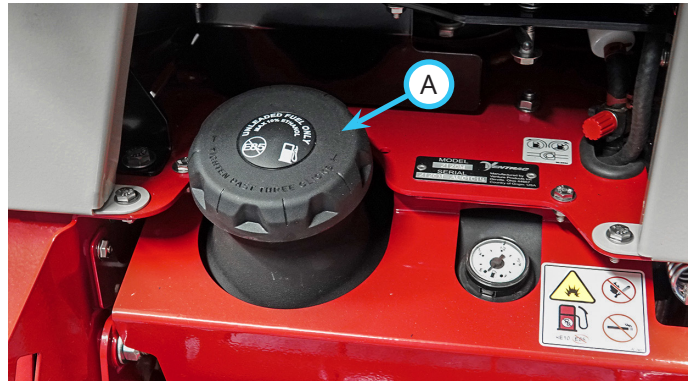

4. Add fuel to the tank until the fuel level reaches the bottom of the fuel neck. Do not overfill by filling the fuel neck, as this may cause engine flooding. Keep the fuel nozzle in contact with the rim of the fuel neck until fueling is completed.
5. Replace the fuel cap and tighten.
6. Wipe up any spills and allow the fuel vapors to dissipate before starting the engine.

SERVICE

Changing the Fuel Filter

1. Turn the fuel shut-off valve to the Off position and allow the engine to run until it stops.
2. Remove the ignition key.
3. Loosen the hose clamps and remove the fuel filter (A).

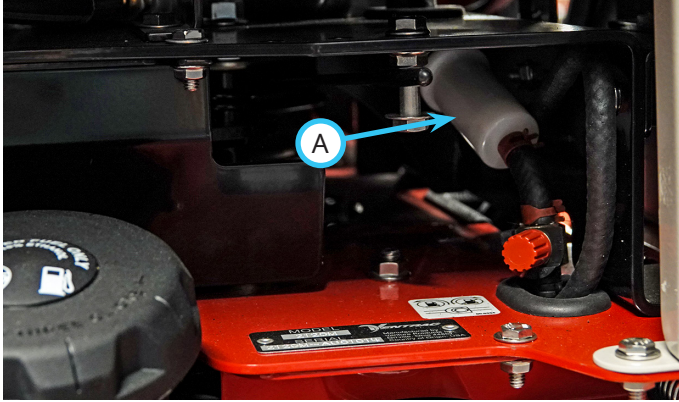

4. Install the new fuel filter with the flow arrow pointing toward the engine and fasten securely with the hose clamps.
5. Turn the fuel shut-off valve to the On position.

ATTENTION

The initial engine start after changing the fuel filter may require a longer cranking time for the engine to start. Do not run the starter continuously for more than 5 seconds. If the engine does not start in this time, wait 1 minute and try again.

6. Start the engine and inspect the filter hose connections for leaks.

Cleaning the Engine Compartment and Engine

Clean the engine compartment and the engine daily or prior to each use, to reduce the risk of the engine overheating or the ignition of accumulated debris.

1. If the power unit has been running, allow the engine to cool.
2. Open the left and right doors.
3. Remove accumulated dust or debris from the engine compartment and the engine. Clean any debris from the rotating screen on the engine.
4. Close the left and right doors.

Servicing the Battery

⚠ DANGER

The battery produces a flammable and explosive gas. The battery may explode.

- Wear eye protection and gloves.
- Do not smoke near the battery.
- Keep arcs, sparks, and open flames away from the battery.
- Do not allow direct metal contact across the battery posts.
- Remove the negative battery cable first when disconnecting the battery.
- Install the negative battery cable last when connecting the battery.

⚠ WARNING

Battery electrolyte contains sulfuric acid. It is poisonous and can cause severe chemical burns.

1. Wear eye and skin protection.
2. If battery electrolyte is spilled on your skin or clothing, change your clothing and wash the affected skin immediately. Seek medical attention, if necessary.
3. If battery electrolyte is splashed into your eyes, flush immediately with water for 15-30 minutes and seek immediate medical attention.
4. If battery electrolyte is swallowed, get medical attention immediately. Drink large quantities of water, followed by Milk of Magnesia, beaten egg, or vegetable oil. DO NOT induce vomiting.

ATTENTION

Batteries contain poisonous and hazardous substances. Dispose of used batteries in accordance with local laws.

SERVICE

Removing the Battery

1. Open the right door.
2. Disconnect the negative (-) battery cable (A).

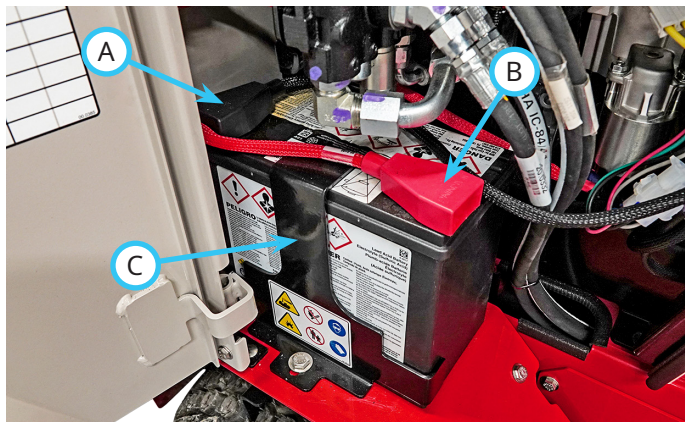

3. Disconnect the positive (+) battery cable (B).
4. Remove the battery mount bracket (C).
5. Remove the battery.

Installing the Battery

1. Place the battery on the right rear fender with the negative post to the rear.
2. Install the battery mount bracket and torque the bolt to 42 Nm (31 ft-lbs).
3. Apply dielectric grease and connect the positive battery cable to the positive battery post first.
4. Apply dielectric grease and connect the negative battery cable to the negative battery post last.
5. Place the covers back over the battery terminals.
6. Close the right door.

Cleaning the Battery and Terminals

1. Remove the battery from the power unit.
2. Wash the battery with a solution of 4 tablespoons (59 mL) of baking soda to 1 gallon (3.8 L) of water. Be careful not to get the soda solution into the cell.
3. Rinse the battery with clean water and wipe dry.
4. Clean the battery posts and the battery cable terminals with a wire brush.
5. Reinstall the battery in the power unit.

Charging the Battery

⚠ DANGER

Batteries produce explosive gases. Charge the battery in a well ventilated area where the gases produced by charging can dissipate. Do not charge where the battery could be exposed to sparks, open flames, or other sources of ignition.

Never charge a frozen battery, as it may explode. Allow the battery to warm up and inspect for cracks or damage before charging.

To preserve optimum battery performance and life, do not allow the battery to stand in a discharged state for long periods of time. If the battery is not being used, check the battery voltage every 30 days and recharge the battery if the voltage drops to 12.4 volts or lower.

Keep the battery fully charged in cold weather to prevent damage due to freezing.

1. If possible, remove the battery from the power unit before charging.
2. Refer to the battery charger's manual for specific charging instructions.
3. If electrolyte is expelled or excessive gassing occurs, or if the temperature of the battery exceeds 52° C (125° F), charging must be temporarily stopped to permit cooling. After cooling, reduce the charging rate before starting the charger again.

Jump Starting Procedure

⚠ DANGER

The battery produces a flammable and explosive gas. The battery may explode.

- Wear eye protection and gloves.
- Do not jump start a cold or frozen battery. Allow the battery to warm up and inspect for cracks or damage.
- Do not jump start a cracked or damaged battery.
- Do not attempt to jump start the power unit using a battery of a different voltage.

1. Inspect the discharged battery for terminal corrosion and loose connections. Clean the terminals and tighten the connections prior to jump starting.
2. Make sure the vehicle used to jump start the power unit has a 12 volt, negative ground, electrical system.

SERVICE

3. Pull the boosting vehicle up close to the disabled power unit. Be sure the vehicles do not touch.
4. Shut off the boosting vehicle's engine and engage the parking brake.

ATTENTION

Attempting to start the disabled unit with the boosting vehicle's engine running could cause damage to the regulator.

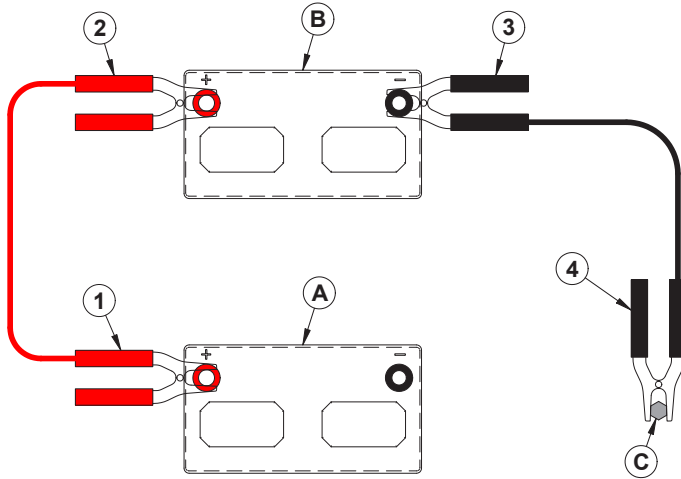

A. Discharged Battery
B. Booster Battery

C. Ground Stud

5. Connect one end of the positive (+) booster cable to the positive (+) terminal (1) of the discharged battery.
6. Connect the other end of the positive (+) booster cable to the positive (+) terminal (2) of the booster battery.
7. Connect the negative (-) booster cable to the negative (-) terminal (3) of the booster battery.
8. Connect the other end of the negative (-) booster cable to the disabled power unit's ground stud (4).
9. Start the disabled power unit and remove the booster cables in reverse order of installation (negative booster cable first).

Replacing Fuses

1. Press the button on the battery disconnect switch.
2. Open the right door.
3. Remove the cover (A) from the fuse panel.

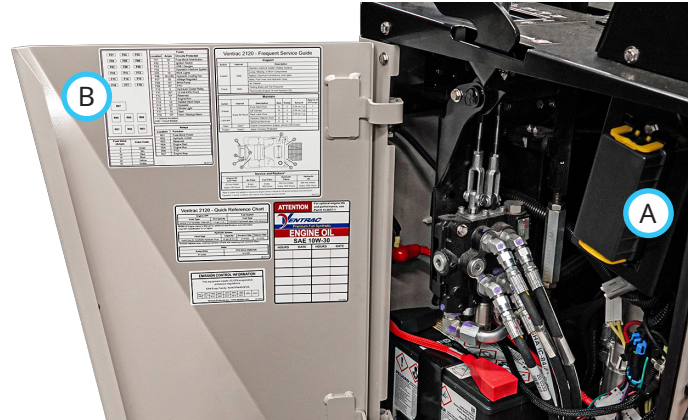

4. Identify and pull the defective fuse from the socket. Fuse positions, amperage, and circuits are printed on the fuse panel decal (B) located on the right door.
5. Insert a new fuse into the socket. Be sure to use the correct amperage fuse or damage may occur to the power unit.
6. Reinstall the sealed cover onto the fuse panel and close the right door.
7. Reset the battery disconnect switch.

Replacing the Head Lights

The head lights are equipped with LEDs and do not use a replaceable bulb. If a head light no longer functions, the entire work light must be replaced.

Replacing the Tail Lights

The optional tail lights are equipped with LEDs and do not use a replaceable bulb. If a tail light no longer functions, the entire tail light must be replaced.

Replacing the Work Lights

The optional work lights are equipped with LEDs and do not use a replaceable bulb. If a work light no longer functions, the entire work light must be replaced.

SERVICE

Replacing the Strobe Lights

The optional strobe lights are equipped with LEDs and do not use a replaceable bulb. If a strobe light no longer functions, the entire strobe light must be replaced. If a strobe light requires replacement, the strobe lights will need to be synchronized after the new light is installed and the flash pattern may need to be reset. Refer to the following sections for the strobe light synchronization and flash pattern change instructions.

Strobe Light Synchronization

1. Turn the ignition key to the engine run position but do not start the engine.
2. Turn the strobe light switch to the On position.
3. Open the right access door and locate the 2 position MP280 connector with a red wire (A-172) and a yellow wire (A-177) (may also have a Strobe Program label on the wire loom).



4. Remove the cap from the connector.
5. Use a jumper wire to connect the two terminals for seven seconds.
6. Remove the jumper wire.
7. Proceed to changing the flash pattern.

Changing the Strobe Light Flash Pattern

The strobe lights have seventeen different flash patterns. To change the flash pattern:

1. Turn the ignition key to the engine run position but do not start the engine.
2. Turn the strobe light switch to the On position.
3. Open the right access door and locate the 2 position MP280 connector with a red wire (A-172) and a yellow wire (A-177) (may also have a Strobe Program label on the wire loom).
4. Remove the cap from the connector.

5. Use a jumper wire to connect the two terminals momentarily (less than 1 second) to change to the next flash pattern. Repeat until the desired flash pattern is reached.
6. Turn the strobe light switch to the Off position.
7. Turn the ignition key to the Stop position.
8. Reinstall the cap onto the connector.
9. Close the right access door.

Belt Inspection

Inspecting the belts of the power unit can prevent sudden belt failure by finding problems before they cause a belt to break. Inspect the belts prior to operation as part of the daily inspection or anytime a problem is suspected. There may be a belt problem if there is a squealing or chattering sound or the smell of a slipping belt.

They belts used on this power unit are a hydraulic pump drive belt and an optional PTO drive belt.

The pump drive belt (A) can be inspected by opening the left door and checking the belt at the pump drive pulley. Removing the pump belt drive cover and disengaging the belt tension spring will allow the belt to be removed from the pump drive pulley for easier inspection.

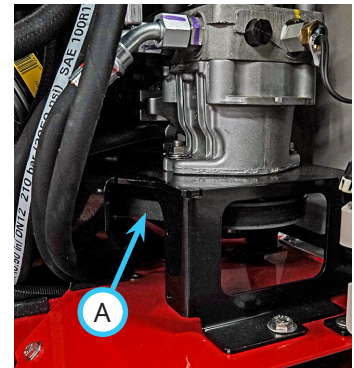

The PTO drive belt (B) can be inspected at the front hitch.

Typical wear on a drive belt may result in the conditions shown in the diagram. If any of these conditions occur, the drive belt will require replacement.

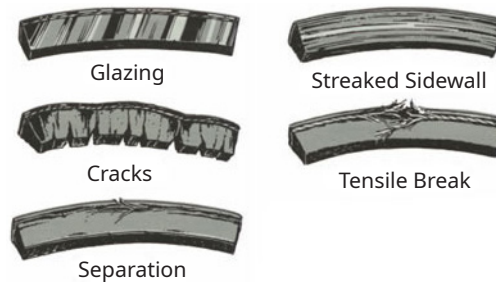
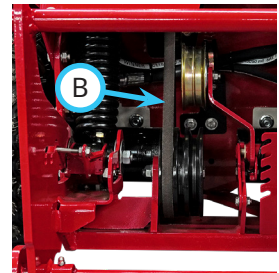

SERVICE

Pump Drive Belt Replacement

1. If the power unit is not equipped with a PTO kit, skip to step 11. If the power unit is equipped with a PTO kit, follow the steps below.
2. If the power unit has been running, allow the engine and muffler to cool before proceeding.
3. Remove the PTO drive cover.
4. Remove the left and right engine covers.
5. Remove the right center fender platform (A).

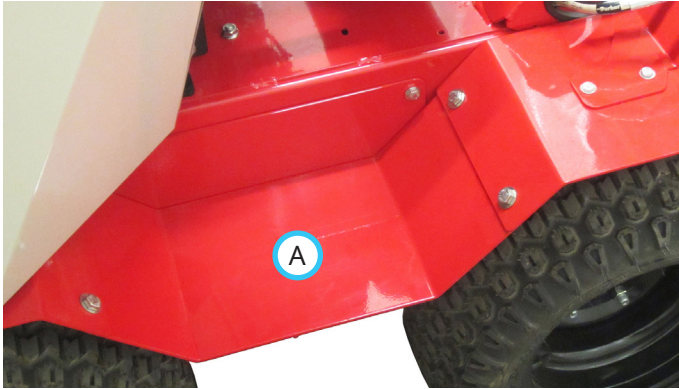

6. Remove the right frame side cover (B).

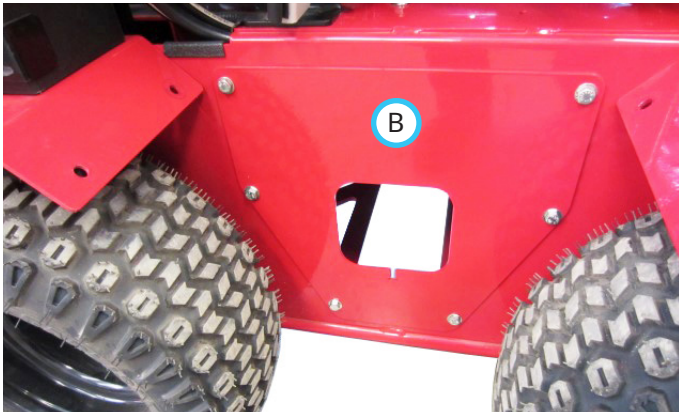

7. Use a 3/8" drive ratchet to rotate the PTO belt tension arm far enough to remove the belt from the belt tension pulley.
8. Remove the PTO belt from the clutch pulley and pull the belt down inside the main frame.
9. Remove the bolts that fasten the clutch torque bracket (C) to the engine mount frame.

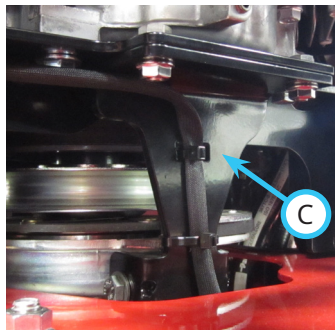

10. Unplug the PTO wire harness connector (D) from the clutch.

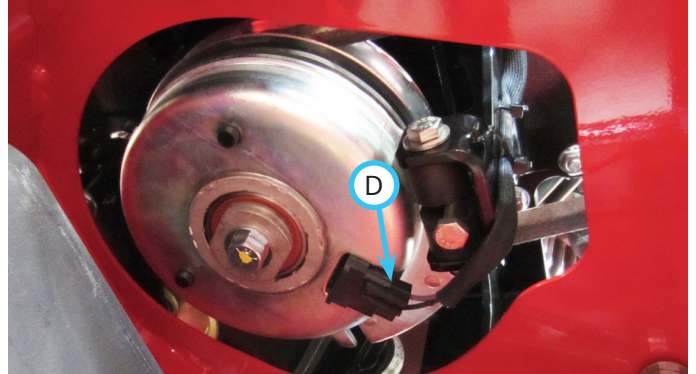

11. Remove the operator cushion.
12. Remove the pump drive belt cover.
13. Disengage the pump belt tension spring.
14. Open the left door.
15. Remove the pump belt from the pump drive pulley.
16. Remove the pump belt from the engine pulley and pull down between the PTO clutch and the clutch torque bracket (if equipped) to remove.
17. Install the new pump belt onto the engine pulley and pump pulley.
18. Ensure the belt is properly seated in the pulleys and engage the belt tension spring.
19. If the power unit is not equipped with a PTO kit, skip to step 27.
20. Reinstall the clutch torque bracket onto the engine mount frame. Make sure the anti-rotation bolt on the clutch is located between the rubber bumpers on the clutch torque bracket. Torque bolts to 24 Nm (210 in-lbs).
21. Reconnect the PTO wire harness to the clutch.
22. Reinstall the PTO belt onto the clutch pulley.
23. Use a 3/8" drive ratchet to rotate the PTO belt tension arm far enough to install the belt onto the belt tension pulley.
24. Reinstall the PTO drive cover. Torque the bolts to 11 Nm (100 in-lbs).
25. Reinstall the right frame side cover and torque the bolts to 24 Nm (210 in-lbs).
26. Reinstall the right center fender platform and torque the bolts to 24 Nm (210 in-lbs).
27. Reinstall the left and right engine covers and torque the bolts to 11 Nm (100 in-lbs).
28. Reinstall the pump belt drive cover and torque the bolts to 11 Nm (100 in-lbs).
29. Reinstall the operator cushion.
30. Close the left door.

SERVICE

PTO Drive Belt Replacement

1. Remove the PTO drive cover.
2. Remove the left and right engine covers.
3. Remove the PTO belt cover.
4. Use a 3/8" drive ratchet to rotate the PTO belt tension arm far enough to remove the belt from the belt tension pulley.
5. Remove the PTO belt from the clutch pulley. Pull the belt end down around the clutch body, then pull forward and up between the clutch torque bracket and the power unit frame.
6. Remove the belt from the front idler pulleys.
7. Install the new belt by sliding one end of the belt down through the main frame in front of the clutch torque bracket. Pull the end back underneath the bracket and install onto the clutch pulley.
8. Route the belt forward to the idler pulleys. Twist the belt so the left side of the belt lays in the v-idler pulley and the back of the right side of the belt lays against the flat idler pulley.
9. Use a 3/8" drive ratchet to rotate the PTO belt tension arm far enough to install the belt onto the double idler pulley. Position in the groove next to the pulley mounting bracket.
10. Reinstall the PTO belt cover and the PTO drive cover. Torque the bolts to 11 Nm (100 in-lbs).
11. Reinstall the left and right engine covers and torque the bolts to 11 Nm (100 in-lbs).

Wheel Removal

1. Loosen the wheel lug nuts, but do not remove.
2. Lift up the power unit to raise the wheel off the ground and secure with a jack stand.
3. Remove the lug nuts and lift the wheel off the mounting studs.

Wheel Installation

1. Place the wheel onto the mounting studs with the hub side of the rim against the axle hub. NOTE: the valve stem will be to the outside of the power unit.
2. Install the lug nuts and tighten by hand until the wheel is held against the axle hub.
3. Lift the power unit up slightly, remove the jack stand, and lower the power unit to the ground.
4. Tighten the wheel nuts in a crisscross sequence as shown. Torque to 115 Nm (85 ft-lbs).

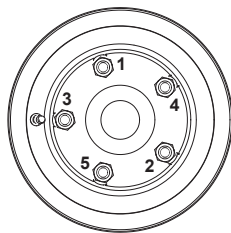

Tire Pressure

Maintain the tire pressure at 124 kPa (18 psi). Check the tire pressure prior to operation, as part of the daily inspection. Keep the tires evenly inflated. Keep the tires inflated to the proper pressure to prevent premature wear and/or poor traction.

Parking Brake Adjustment

As the tire tread wears down, the parking brake will need to be adjusted in order to hold securely.

When replacing worn tires with new tires, the parking brake will need to be adjusted in order to properly engage.

⚠ WARNING

The parking brake must be disengaged as part of the adjustment procedure. Park the power unit on a level surface and place wheel chocks in front and back of the wheels to prevent the power unit from rolling forward or backward.

1. Place wheel chocks in front and back of the wheels to prevent the power unit from rolling during the adjustment procedure.
2. Disengage the parking brake.
3. Loosen the locking nuts (A) on the sleeve nut (B).

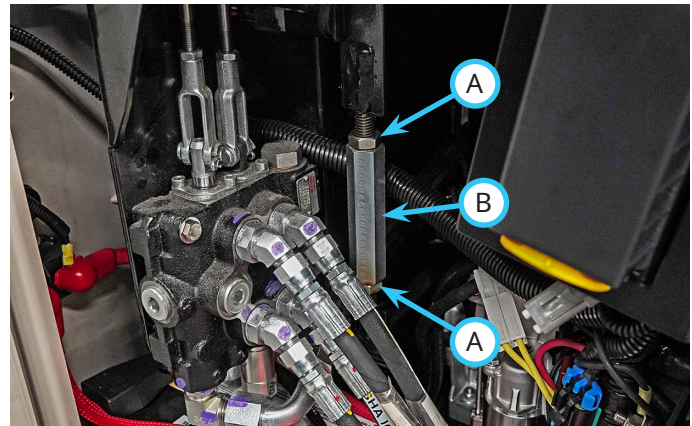

4. Turn the sleeve nut to raise or lower the brake plates that contact the tires.
5. Adjust the sleeve nut until the parking brake handle requires 20.5 - 22.7 kg (45 - 50 lbs) of force to engage the parking brake.
6. Tighten the locking nuts against the sleeve nut.
7. Engage the parking brake and remove the wheel chocks.

SERVICE

Parking Brake Switch Adjustment

An improperly adjusted parking brake switch can prevent the engine from cranking. If the parking brake is engaged, but the parking brake indicator light on the cluster gauge is not activated, the parking brake switch will need to be adjusted.

1. Engage the parking brake.
2. Open the right door.
3. Loosen the hardware (A) that fastens the parking brake switch bracket to the frame panel.

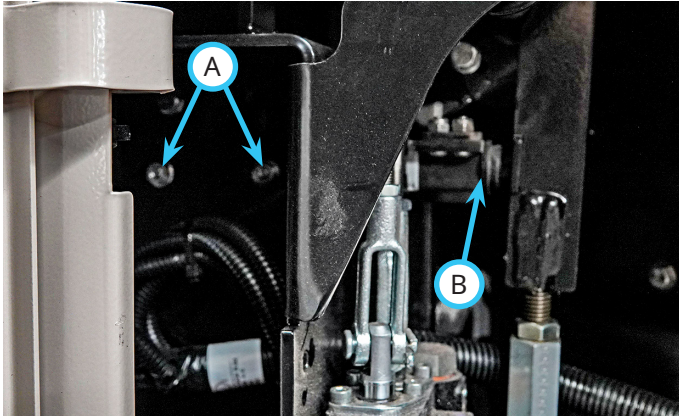

4. Position the bracket so the switch (B) is activated by the parking brake link and tighten the hardware to secure the switch bracket.
5. Turn the ignition key to the On position and check the cluster gauge to verify the parking brake indicator light is activated.
6. Torque the mounting bolts to 11 Nm (100 in-lbs) and close the right door.

Operator Presence Switch Adjustment

⚠ WARNING

An improperly adjusted operator presence switch can prevent the power unit from operating or can allow unsafe power unit movement and operation.

⚠ WARNING

The parking brake must be disengaged as part of the adjustment procedure. Park the power unit on a level surface and place wheel chocks in front and back of the wheels to prevent the power unit from rolling forward or backward.

1. Place wheel chocks in front and back of the wheels to prevent power unit from rolling during the adjustment procedure.

2. Loosen the hardware that fastens the platform switch bracket (A) to the frame.

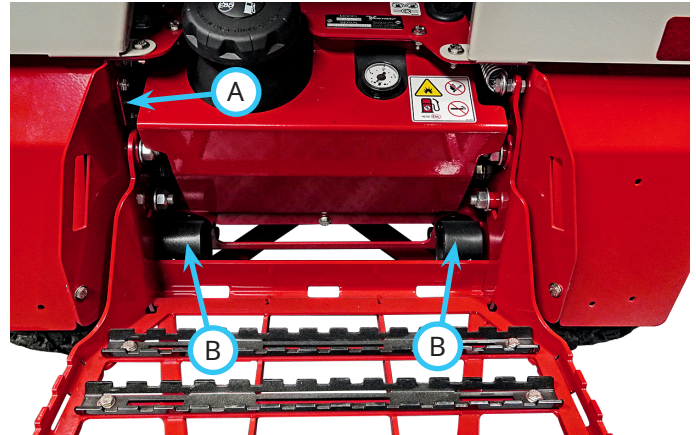

3. Move the switch bracket up or down in small increments. If the power unit fails test number 9 in the Safety Interlock System section, the switch bracket must be moved up away from the platform. If the engine shuts off when the parking brake is disengaged but the operator is present on the platform, the switch bracket will need to be moved down toward the platform.
4. Disengage the parking brake.
5. Turn the ignition key to the On position, but do not start the engine.
6. Move the operator platform down until a click can be heard from the relay in the fuse panel and note the position of the platform.
7. Adjust the switch bracket until the relay activates at approximately the position when the operator platform contacts the elastomer springs (B) on the power unit frame.
8. After adjustment is complete, torque the platform switch bracket hardware to 100 in-lbs (11 Nm).
9. Engage the parking brake, turn the ignition key to the Off position, and remove the wheel chocks.

SERVICE

Drive Control Handle and Neutral Lock Rocker Arm Adjustment

Note: drive tracking and top forward speed are controlled by the pump stop bolt (A) on both pumps. The pump stop bolts are set at the factory and are not intended to be adjusted.

To check and adjust the neutral lock rocker arms and drive control handles:

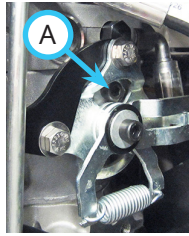

1. Remove the operator cushion.

WARNING

The parking brake may need to be disengaged as part of the adjustment procedure. Park the power unit on a level surface and place wheel chocks in front and back of the wheels to prevent the power unit from rolling forward or backward.

2. Place wheel chocks in front and back of wheels to prevent power unit from rolling during adjustment procedure.
3. Check the gap between the bearings on the neutral lock rocker arm (A) and the back of the neutral lock plates (B). There should be an approximately 1.5 mm (1/16 inch) gap.

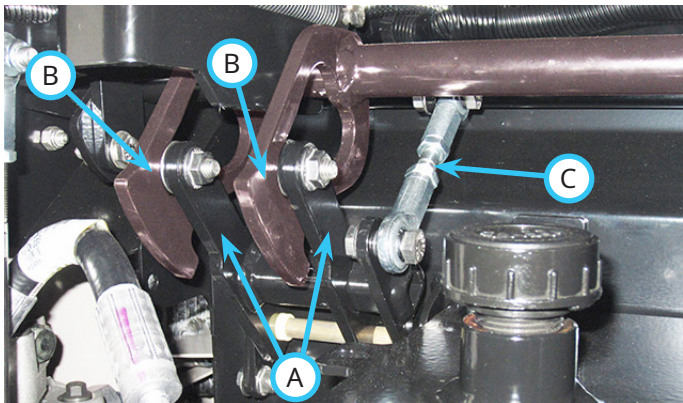

4. If the neutral lock rocker arm needs to be adjusted, loosen the jam nuts from the rod ends on the neutral lock link rod (C).
5. Adjust the neutral lock rocker arm by turning the neutral lock link rod. Lengthen the rod to move the bearings toward the back of the neutral lock plates. Shorten the rod to move the bearings away from the back of the neutral lock plates.
6. When adjustment is complete, tighten the jam nuts against the rod ends.
7. Check to make sure the bearings on the neutral lock rocker arm are not under tension from contact with the upper or lower edge of the pocket in the neutral lock plates.

8. If the bearings are under tension, the pump link rods will need to be adjusted.
9. Remove the four bolts that fasten the left rear tower cover (D) to the power unit and remove the cover to access the pump control links.

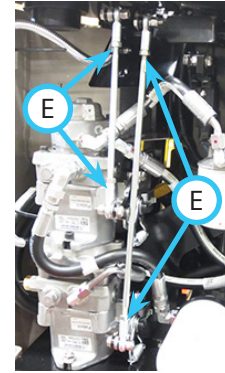

10. Loosen the jam nuts (E) from the rod ends on the pump link rod requiring adjustment and turn the rod to adjust the neutral lock plate. Lengthen the pump link rod to raise the neutral lock plate and shorten the rod to lower the neutral lock plate. The pump link rod will turn easily when tension is released and the bearings are not making contact with the neutral lock plates.
NOTE: the longer pump link rod adjusts the right drive control handle and neutral lock plate. The shorter pump link rod adjusts the left drive control handle and neutral lock plate.
11. When adjustment is complete, tighten the jam nuts against the rod ends.
12. Set the front control grab handles in the full forward position.
13. Disengage the parking brake.
14. Loosen the hardware (F) that fastens the right drive control handle to the right control arm.
15. Raise the pump control arm (G) for the right drive pump until it contacts the stop on the pump. Secure the pump control arm in this position until the right drive control handle has been adjusted and fastened in place.

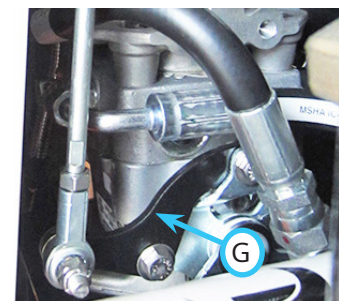
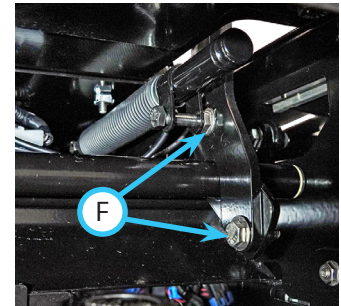

SERVICE

16. Push the right drive control handle forward until the tip of the drive handle just contacts the front control grab handle.

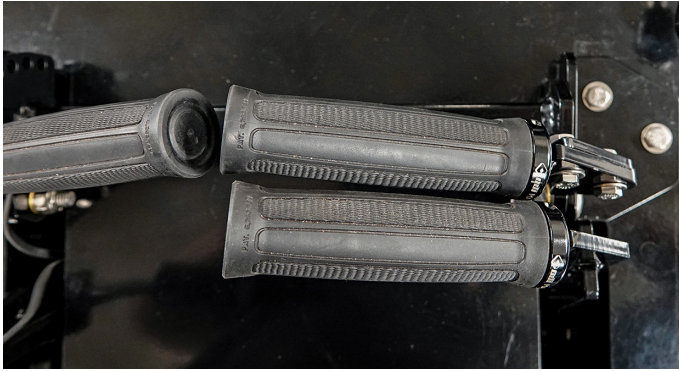

17. Tighten the hardware that fastens the right drive control handle to the right control arm. Torque to 24 Nm (210 in-lbs).
18. Release the right pump control arm.
19. Repeat steps 14 - 18 for the left drive control arm.
20. Check to ensure the left and right drive control handles are aligned when returned to the neutral position.
21. Check to ensure the left and right drive control handles do not move when the parking brake is engaged.
22. Reinstall the left rear tower cover. Torque the bolts to 11 Nm (100 in-lbs).
23. Reinstall the operator cushion.

Backup Alarm Switch Adjustment

The backup alarm is activated by two switches that are engaged when the drive control handles are moved in reverse. If the switches are out of adjustment, the alarm may not sound when the power unit is driven in reverse, or the alarm may sound when the power unit is not in reverse. To adjust the backup alarm switches:

1. Remove the operator cushion.

WARNING

The parking brake must be disengaged as part of the adjustment procedure. Park the power unit on a level surface and place wheel chocks in front and back of the wheels to prevent the power unit from rolling forward or backward.

2. Place wheel chocks in front and back of wheels to prevent power unit from rolling during adjustment procedure.

3. Loosen the bolt (A) that fastens the switch mounting plate to the switch bracket.

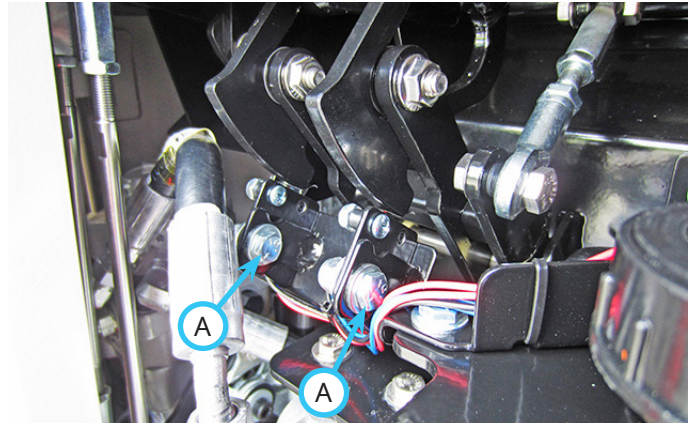

4. Raise the mounting plate and switch until you hear the switch click to engage.
5. Lower the switch slightly until the switch disengages and tighten the bolt.
6. Repeat steps 3 - 5 for the second switch.
7. Disengage the parking brake and turn the ignition key to the On position without starting the power unit engine.
8. Pull the left drive control handle all the way back, then pull the right drive control handle backward. The backup alarm should sound before the right handle moves more than 3/8 inch (9.5 mm).
9. Pull the right drive control handle all the way back, then pull the left drive control handle backward. The backup alarm should sound before the left handle moves more than 3/8 inch (9.5 mm).
10. If either switch does not activate within the stated range of movement, readjust that switch until it is set in the correct range.
11. Engage the parking brake and remove the key from the ignition switch.
12. Torque the bolts on both switch mounting plates to 11 Nm (100 in-lbs).
13. Reinstall the operator cushion.

SERVICE

Weight Transfer Spring Inspection and Adjustment

If the weight transfer adjustment knob does not easily move between positions, the weight transfer spring may need to be adjusted.

1. Remove the lock nut (A) and the fender washer (B) from the bolt in the lower end of the weight transfer spring assembly.

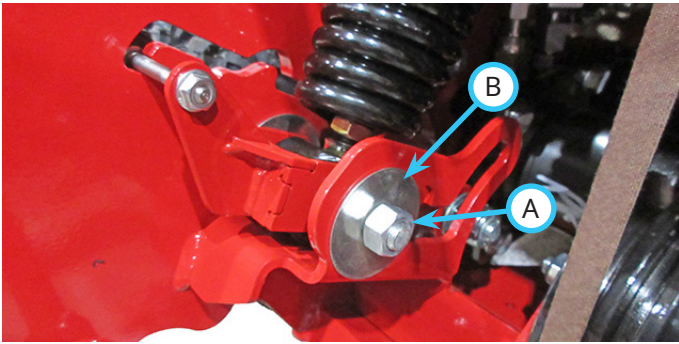

2. Check to see if the bolt is centered in the weight transfer slot as shown. If the bolt is not centered in the slot, the spring assembly length must be adjusted.

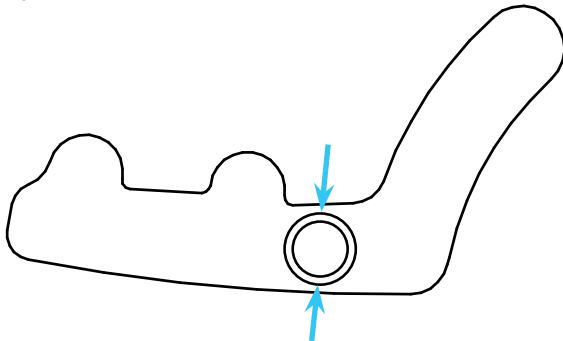

3. Loosen the locking nut (C) and tighten the adjusting nut (D) to lengthen the assembly or loosen the adjusting nut to shorten the assembly.

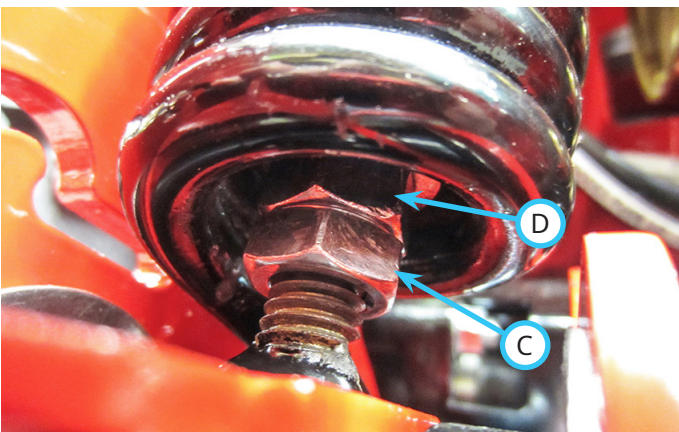

4. When the spring assembly is adjusted correctly to center the bolt in the weight transfer slot, tighten the locking nut against the adjusting nut to lock the adjusting nut in place.
5. Install the fender washer (B) onto the bolt and fasten with the lock nut (A). Tighten the lock nut until there is a 1.5 - 3 mm (1/16 - 1/8 inch) clearance between the fender washer and the weight transfer bracket.

Storage

Preparing the Power Unit for Storage

1. Clean the power unit.

ATTENTION

Attempting to start the disabled unit with the boosting vehicle's engine running could cause damage to the regulator.

2. Inspect for loose or missing hardware, damaged components, or signs of wear. Repair or replace any damaged or worn components.
3. Inspect the safety decals. Replace any decals that are faded, illegible, or missing.
4. Inspect the hydraulic hoses and fittings for leaks and/or wear. Service as required.
5. Inspect the fuel lines for leaks.
6. Ensure the parking brake is properly adjusted.
7. Inspect the electrical system and connections.
8. Test the operator safety interlock system.
9. Inspect the belts and pulleys for damage or excessive wear. Service as required.
10. Check the hydraulic oil level. Add fluid or service as required.
11. Ensure the air cleaner and engine compartment are clean.
12. Check the tires for proper inflation.
13. Grease or lubricate all points specified in the Lubrication Locations section. Wipe off any excess grease or oil.
14. Inspect the painted components for chips, scratches, or rust. Clean and touch up the surfaces as needed.

After all the above steps have been performed, complete the preparation for storage by performing the steps for either long term storage (four months or longer) or short term storage (less than four months).

SERVICE

Long Term Storage (4 Months or Longer)

1. Change the engine oil to prevent damage that can be caused by acidic buildup in used motor oil.
2. Drain all the fuel out of the fuel tank, start the power unit's engine, and allow to run until the engine stops to ensure all the fuel is out of the fuel lines, carburetor passages, injectors, etc.
3. Turn the key to the Off position and remove the ignition key.
4. Engage the parking brake.
5. Turn the fuel shut-off valve to the Off position.
6. Press the button on the battery disconnect switch.
7. If the power unit is being stored in a cold climate (below 2° C [35° F]), remove the battery from the power unit and store in a warm location. Check the battery charge periodically and charge the battery, if needed.

Short Term Storage (Less Than 4 Months)

1. Add a quality gasoline fuel stabilizer to the fuel tank. Follow the manufacturer's recommended mixing ratios.
2. Start the power unit's engine and run for ten minutes to allow the fuel stabilizer to travel all through the fuel system.
3. Shut off the engine and remove the ignition key.
4. Engage the parking brake.
5. Turn the fuel shut-off valve to the Off position.
6. Press the button on the battery disconnect switch.
7. Check the battery charge periodically and charge the battery, if needed.

Removing the power Unit from Storage

1. Clean the power unit to remove any accumulated dust or debris.
2. Inspect the power unit as instructed in the Daily Inspection section of this manual.
3. Test the power unit to ensure that all the components and systems are working properly.

SERVICE

Maintenance Schedule

Maintenance Schedule	# of locations	# of pumps	As Needed	After First 8 Hours	Daily	At 50 hours	At 100 hours	At 150 hours	At 200 hours	At 250 hours	At 300 hours	At 350 hours	At 400 hours	At 450 hours	At 500 hours	At 550 hours	At 600 hours	At 650 hours	At 700 hours	At 750 hours	At 800 hours	At 850 hours	At 900 hours	At 950 hours	At 1,000 hours	Yearly	1,500 Hours*	
Grease and Lubrication: Refer to the Lubrication Section																												
Front Hitch Pivot	2	1	✓			✓	✓	✓	✓	✓	✓	✓	✓	✓	✓	✓	✓	✓	✓	✓	✓	✓	✓	✓	✓	✓		
Attachment Latch Handle Pivot	2	1	✓			✓	✓	✓	✓	✓	✓	✓	✓	✓	✓	✓	✓	✓	✓	✓	✓	✓	✓	✓	✓	✓		
Lift Cylinder	2	1	✓			✓	✓	✓	✓	✓	✓	✓	✓	✓	✓	✓	✓	✓	✓	✓	✓	✓	✓	✓	✓	✓		
Operator Platform Pivot	2	#	✓			✓	✓	✓	✓	✓	✓	✓	✓	✓	✓	✓	✓	✓	✓	✓	✓	✓	✓	✓	✓	✓		
Spherical Rod Ends	6	#	✓			✓	✓	✓	✓	✓	✓	✓	✓	✓	✓	✓	✓	✓	✓	✓	✓	✓	✓	✓	✓	✓		
Engine¹																												
Check the Engine Oil Level					✓																							
Change the Engine Oil and Filter ¹			✓			✓	✓	✓	✓	✓	✓	✓	✓	✓	✓	✓	✓	✓	✓	✓	✓	✓	✓	✓	✓	✓		
Clean or Replace the Spark Plugs						✓	✓	✓	✓	✓	✓	✓	✓	✓	✓	✓	✓	✓	✓	✓	✓	✓	✓	✓	✓	✓	✓	
Inspect the Air Filter					✓																							
Replace the Air Filter			**			✓	✓	✓	✓	✓	✓	✓	✓	✓	✓	✓	✓	✓	✓	✓	✓	✓	✓	✓	✓	✓		
Clean the Engine Compartment, Engine, and the Engine Rotating Screen			**		✓																							
Clean the Oil Cooler Fins			**										✓								✓							
Check the Valve Clearance									✓						✓					✓					✓			
Replace the Fuel Filter			✓									✓								✓								
Drain Water and Sediment from Fuel Tank			✓																						✓			
Hydraulic System																												
Check the Hydraulic Oil Level					✓																							
Change the Hydraulic Filters ^{**}															✓													✓
Change the Hydraulic Oil ^{**}														✓														✓
Parking Brake																												
Parking Brake Inspection and Adjustment					✓																							
Electrical																												
Clean the Battery Terminals and Compartment			✓																									✓
Inspection																												
Inspect the Operator Interlock System					✓																							
Inspect the Safety Decals					✓																							
Inspect for Loose, Missing, or Worn Components					✓																							
Inspect the Battery, Electrical Connections, and Lights					✓																							
Inspect the Belts, Fuel Lines, and Hydraulic Lines					✓																							
Check the Tire Pressure					✓																							
Check the Wheel Lug Nuts. Torque to 115 Nm (85 ft-lbs)						✓	✓	✓	✓	✓	✓	✓	✓	✓	✓	✓	✓	✓	✓	✓	✓	✓	✓	✓	✓	✓		
Check the Front Hitch Pivot Bolts. Torque to 203 Nm (150 ft-lbs)							✓	✓	✓	✓	✓	✓	✓	✓	✓	✓	✓	✓	✓	✓	✓	✓	✓	✓	✓	✓		
**Operation in severe conditions may require more frequent service intervals.																												
¹ Consult the Engine Owner's Manual for engine oil information and complete servicing information.																												
*Silicon Based Spray Lubricant																												
^{**} Hydraulic oil and filters: initial change at 500 hours, then change the hydraulic oil and filters every 1,000 hours.																												

SERVICE

Maintenance Checklist

Maintenance Schedule	# of locations	# of pumps	As Needed	After First 8 Hours	Daily	At 50 hours	At 100 hours	At 150 hours	At 200 hours	At 250 hours	At 300 hours	At 350 hours	At 400 hours	At 450 hours	At 500 hours	At 550 hours	At 600 hours	At 650 hours	At 700 hours	At 750 hours	At 800 hours	At 850 hours	At 900 hours	At 950 hours	At 1,000 hours	Yearly	1,500 Hours*
Grease and Lubrication: Refer to the Lubrication Section																											
Front Hitch Pivot	2	1																									
Attachment Latch Handle Pivot	2	1																									
Lift Cylinder	2	1																									
Operator Platform Pivot	2	#																									
Spherical Rod Ends	6	#																									
Engine ¹																											
Check the Engine Oil Level																											
Change the Engine Oil and Filter ¹																											
Clean or Replace the Spark Plugs																											
Inspect the Air Filter																											
Replace the Air Filter																											
Clean the Engine Compartment, Engine, and the Engine Rotating Screen																											
Clean the Oil Cooler Fins																											
Check the Valve Clearance																											
Replace the Fuel Filter																											
Drain Water and Sediment from Fuel Tank																											
Hydraulic System																											
Check the Hydraulic Oil Level																											
Change the Hydraulic Filters [%]																											
Change the Hydraulic Oil [%]																											
Parking Brake																											
Parking Brake Inspection and Adjustment																											
Electrical																											
Clean the Battery Terminals and Compartment																											
Inspection																											
Inspect the Operator Interlock System																											
Inspect the Safety Decals																											
Inspect for Loose, Missing, or Worn Components																											
Inspect the Battery, Electrical Connections, and Lights																											
Inspect the Belts, Fuel Lines, and Hydraulic Lines																											
Check the Tire Pressure																											
Check the Wheel Lug Nuts. Torque to 115 Nm (85 ft-lbs)																											
Check the Front Hitch Pivot Bolts. Torque to 203 Nm (150 ft-lbs)																											
**Operation in severe conditions may require more frequent service intervals.																											
¹ Consult the Engine Owner's Manual for engine oil information and complete servicing information.																											
[*] Silicon Based Spray Lubricant																											
[%] Hydraulic oil and filters: initial change at 500 hours, then change the hydraulic oil and filters every 1,000 hours.																											

TROUBLESHOOTING

Engine

Symptom:	Possible Cause:
The starter will not engage.	The battery disconnect switch is in the Off position. The PTO switch is engaged. A blown fuse in the start circuit. The parking brake is not engaged. The parking brake switch is out of adjustment. Low battery voltage.
The engine cranks, but won't start.	The fuel shut-off valve is turned off. The fuel tank is empty. A faulty fuel pump. A plugged fuel filter. A blockage in the fuel line. Poor engine compression.
The engine runs rough.	Plugged or partially plugged air filter. Plugged or partially plugged fuel filter. Stale, dirty fuel or wrong seasonal fuel mixture. The fuel level is low. Faulty spark plugs. Moisture in the spark plug pockets. Incorrect choke setting. A faulty fuel pump. Dirty or faulty carburetor. Incorrect valve clearance. Valve seat failure.
The engine is low on power.	Plugged or partially plugged air filter. Plugged or partially plugged fuel filter. Dirty or faulty carburetor. Low cylinder compression.
The engine overheats.	The engine compartment has debris buildup.
The oil light comes on when the engine is running.	The oil level is low. A faulty oil sender. A faulty or plugged oil pump.
The engine emits white smoke.	The engine temperature is low.
The engine uses excessive fuel.	Plugged or restricted air filter or air intake hoses. A dirty or faulty carburetor.
The engine uses excessive oil.	The engine has an oil leak. The oil is an incorrect viscosity. Plugged or restricted air filter or air intake hoses. The engine has worn rings or cylinder walls. The engine has worn or faulty valves.

TROUBLESHOOTING

Electrical

Symptom:	Possible Cause:
The battery does not charge.	Loose or corroded battery connections. A broken or loose wire in the charge system. A blown fuse in the charge system. The battery is defective. A faulty regulator. A faulty alternator.
The lights do not activate.	A blown fuse. A faulty light. A broken wire. A faulty light switch.
The PTO does not engage.	A blown fuse. The operator is not on the operator platform. A faulty or out of adjustment operator presence switch. A faulty PTO switch. A faulty PTO relay. PTO belt failure. A faulty clutch.

Hydraulic

Symptom:	Possible Cause:
The front attachment does not lift.	The hydraulic oil level is low. An excessive load on the front lift. The hydraulic oil suction filter is plugged. A faulty hydraulic lift cylinder. The pump charge pressure is low. Missing hardware on the lift cylinder. Missing hardware on the hydraulic control lever links.
Excessive noise in the hydraulic system.	The hydraulic oil level is low. The hydraulic oil suction filter is plugged. Incorrect oil used in the hydraulic system. Cold weather - allow the power unit to warm up.
The cooler fan isn't working, the hydraulic system overheats.	The circuit breaker for the hydraulic cooling fan is tripped. The hydraulic cooler is dirty/plugged . A faulty hydraulic cooling fan temperature sender. A faulty hydraulic cooling fan. The hydraulic system is overstressed.

TROUBLESHOOTING

Power Unit

Symptom:	Possible Cause:
The power unit will not move with the engine running.	The hydraulic oil level is low. The parking brake is engaged. The pump control rod linkage is loose or disconnected. The tow valve is bypassing at the hydraulic pump. Pump drive belt failure. A faulty hydraulic pump or motor.
The engine stalls when the parking brake is disengaged while the operator is on the platform.	Faulty or out of adjustment operator presence switch.

SPECIFICATIONS

Engine

Manufacturer	Vanguard
Model Number	386777
Type	Gasoline
Cylinders.	2
Displacement	627 cc (38.26 ci)
Engine Gross Power	17 kW (23 Hp)
Peak Torque.	43.4 Nm (32 ft-lbs) @ 3,000 RPM
Operating Range	1,550-3,600 RPM
Cooling System	Air Cooled
Alternator	20-50 Amp

Electrical

Battery.	500 Cold Cranking Amps
Voltage.	12 Volts

Power Train

Type	Hydrostatic (All Wheel Drive)
Forward Speed	12.9 km/h (8 mph)
Reverse Speed	9.7 km/h (6 mph)
Brakes	Hydro-Dynamic
Hydraulic Oil Filtration	10 Micron and 25 Micron

Controls and Instrument Panel

Throttle Control.	Cable
Directional Control	Right and Left Drive Control Handles
Gauges.	Hour Meter, Fuel
Parking/Emergency Brake.	Tire Brake Bar
Optional PTO (Power Take Off)	Electric with Brake

Other Features

Tires	18 x 8.5-10 (46 x 22-26 cm)
Headlight	LED (1,000 Lumen)
Attachment System	Quick Attach Hitch

SPECIFICATIONS

Dimensions

Wheelbase.	71 cm (28 inches)
Overall Length	170 cm (67 inches)
Overall Height.	140 cm (55 inches)
Overall Width	86.4 cm (34 inches)
Weight*	453.6 kg (1,000 pounds)

Venture Products, Inc. reserves the right to change these specifications without notice.

*Weight varies based on setup (optional accessories).

Fluid Capacities and Specifications

	Fluid Type	Capacity	Filter #1	Filter #2
Engine Oil	Synthetic 10W-30*	1.4 liters (1.5 quarts)	13.842921	-
Hydraulic Oil	HydroTorq XL Synthetic Hydraulic Oil	9.5 liters (10 quarts)	21.0122 (Suction filter)	21.0124 (Return filter)
Fuel System	Unleaded Gasoline (Max 10% Ethanol)	12.5 liters (3.3 gallons)	13.691035	-
Grease	Lithium Complex NLGI #2	Refer to the Maintenance Chart	-	-

* = Use API Classification SJ or higher. For optimal engine life and performance, use Ventrac full synthetic engine oil (Part Number 15.0037-1).

Belt Chart

Location	Belt Size	Ventrac Part Number
Pump Drive Belt	B41 Custom	81.0164
PTO Drive Belt (Optional)	B86 Custom	81.0167

Visit ventrac.com/manuals for the latest version of this operator's manual. A downloadable parts manual is also available.

[View all manuals](#)

