



Operator's Manual
& Parts Drawings

ND420

Snow Plow

Serial Number ND420-AA01001 - AA01428





500 Venture Drive
Orrville Oh 44667
www.ventrac.com

View all manuals



Visit ventrac.com/manuals for the latest version of this operator's manual.

A downloadable parts manual is also available.

To the Owner Contact Information and Product Identification

If you need to contact an authorized Ventrac dealer for information on servicing your product, always provide the product model and serial numbers.

Please fill in the following information for future reference. See the picture(s) below to find the location of the identification numbers. Record them in the spaces provided.

Date of Purchase: _____

Dealer: _____

Dealer Address: _____

Dealer Phone Number: _____

Dealer Fax Number: _____

Model # (A): _____

Serial # (B): _____

Affix Part/Serial Number label here.

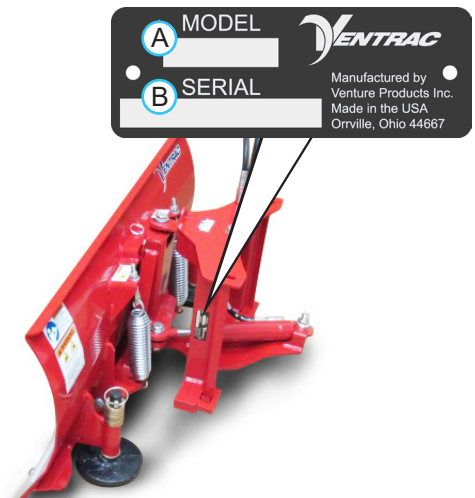

Venture Products Inc. reserves the right to make changes in design or specifications without obligation to make like changes on previously manufactured products.

TABLE OF CONTENTS

INTRODUCTION	PAGE 5
Product Description	5
Why Do I Need an Operator's Manual?	5
Using Your Manual	6
Manual Glossary	6
SAFETY	PAGE 7
Safety Decals	7
General Safety Procedures	8
Training Required	8
Personal Protective Equipment Requirements	8
Operation Safety	8
Preventing Accidents	9
Keep Riders Off	9
Operating On Slopes	10
Roadway Safety	10
Truck Or Trailer Transport	10
Maintenance	11
Fuel Safety	11
Hydraulic Safety	12
ND420 Safety Procedures	13
OPERATIONAL CONTROLS	PAGE 14
Safety Trip Control	14
Plow Blade Angle	14
GENERAL OPERATION	PAGE 15
Daily Inspection	15
Attaching	15
Detaching	15
Operating Procedure	15
Transport of Snow Plow	16
Resetting the Blade Safety Trip Control	16
Skid Shoe Adjustment	16
SERVICE	PAGE 17
Cleaning and General Maintenance	17
Cutting Edge Reversal/Replacement	17
Skid Shoe Replacement	17
Optional Polyurethane Cutting Edge Adjustment/Reversal	17
Lubrication Locations	18
Storage	18
Maintenance Schedule	19
Maintenance Checklist	19

TABLE OF CONTENTS

SPECIFICATIONS	PAGE 20
Dimensions	20
Features	20
PARTS	PAGE 22
Hitch Frame & Upper Link.....	22
Blade Pivot Frame, Blade, & Cutting Edge	24
Hydraulic Power Angle	26
70.8181 Polyurethane Edge Kit	28
WARRANTY	PAGE 30

INTRODUCTION



Venture Products Inc. is pleased to provide you with your new Ventrac snow plow! We hope that Ventrac equipment will provide you with a ONE Tractor Solution.

Listed below are just some of the items that can provide you *versatility* as you use your snow plow. Please visit our website, or contact your authorized Ventrac dealer for a complete list of items available for your new ND420 snow plow.

Accessories	Item Description	Part Number
	Polyurethane Cutting Edge Kit	70.8181

Product Description

The Ventrac ND420 snow plow is designed solely for the purpose of snow removal from sidewalks and other small areas that are difficult to reach or clear with large equipment.

The snow plow has a working width of 42 inches (107 cm) and can be angled 30 degrees in either direction. The snow plow is raised, lowered, and angled using the power unit's auxiliary control lever.

Adjustable skid shoes allow the plow height to be adjusted to match cutting edge wear and surface conditions.

Why Do I Need an Operator's Manual?

This manual has been created to help you gain the important knowledge of what is needed to safely operate, maintain, and service your machine. It is divided into sections for convenient reference of the appropriate section.

You must read and understand the operator's manual for each piece of Ventrac equipment you own. Reading the operator's manual will help you become familiar with each specific piece of equipment. Understanding the operator's manual will help you, as well as others, avoid personal injury and/or damage to the equipment. Keep this manual with the machine at all times. The manual should remain with the machine even if it is sold. If this manual becomes damaged or unreadable, it should be replaced immediately. Contact your local Ventrac dealer for a replacement.

When using a Ventrac attachment, be sure to read and follow the safety and operating instructions of both the power unit and the attachment being used to ensure the safest operation possible.

The information in this manual provides the operator with the safest procedures to operate the machine while getting the maximum use out of the unit. Failure to follow the safety precautions listed in this manual may result in personal injury and/or damage to the equipment.

INTRODUCTION

Using Your Manual

Throughout this manual, you will encounter special messages and symbols that identify potential safety concerns to help you as well as others avoid personal injury or damage to the equipment.

SYMBOL DEFINITIONS



ATTENTION

This symbol identifies potential health and safety hazards. It marks safety precautions. Your safety and the safety of others is involved.

There are three signal words that describe the level of safety concern: Danger, Warning, and Caution. Safety should always be the #1 priority when working on or operating equipment. Accidents are more likely to occur when proper operating procedures are not followed or inexperienced operators are involved.

Note: Right-Hand and Left-Hand orientations may be referred to at different places throughout this manual. Right-Hand and Left-Hand is determined as if facing forward from the operator station.

SIGNAL WORD DEFINITIONS

⚠ DANGER

Indicates an imminently hazardous situation which, if not avoided, will result in death or serious injury. This signal word is limited to the most extreme cases.

⚠ WARNING

Indicates a potentially hazardous situation which, if not avoided, could result in death or serious injury.

⚠ CAUTION

Indicates a potentially hazardous situation which, if not avoided, may result in minor or moderate injury and/or property damage. It may also be used to alert against unsafe practices.

Manual Glossary

Power Unit A Ventrac tractor or other Ventrac engine powered device that may be operated by itself or with an attachment or accessory.

Attachment A piece of Ventrac equipment that requires a Power Unit for operation.

Accessory A device that attaches to a Power Unit or Attachment to extend its capabilities.

Machine Describes any "Attachment" or "Accessory" that is used in conjunction with a power unit.

SAFETY

Safety Decals

The following safety decals must be maintained on your ND420 snow plow.

Keep all safety decals legible. Remove all grease, dirt, and debris from safety decals and instructional labels. If any decals are faded, illegible, or missing, contact your dealer promptly for replacements.

When new components are installed, be sure that current safety decals are affixed to the replacement components.

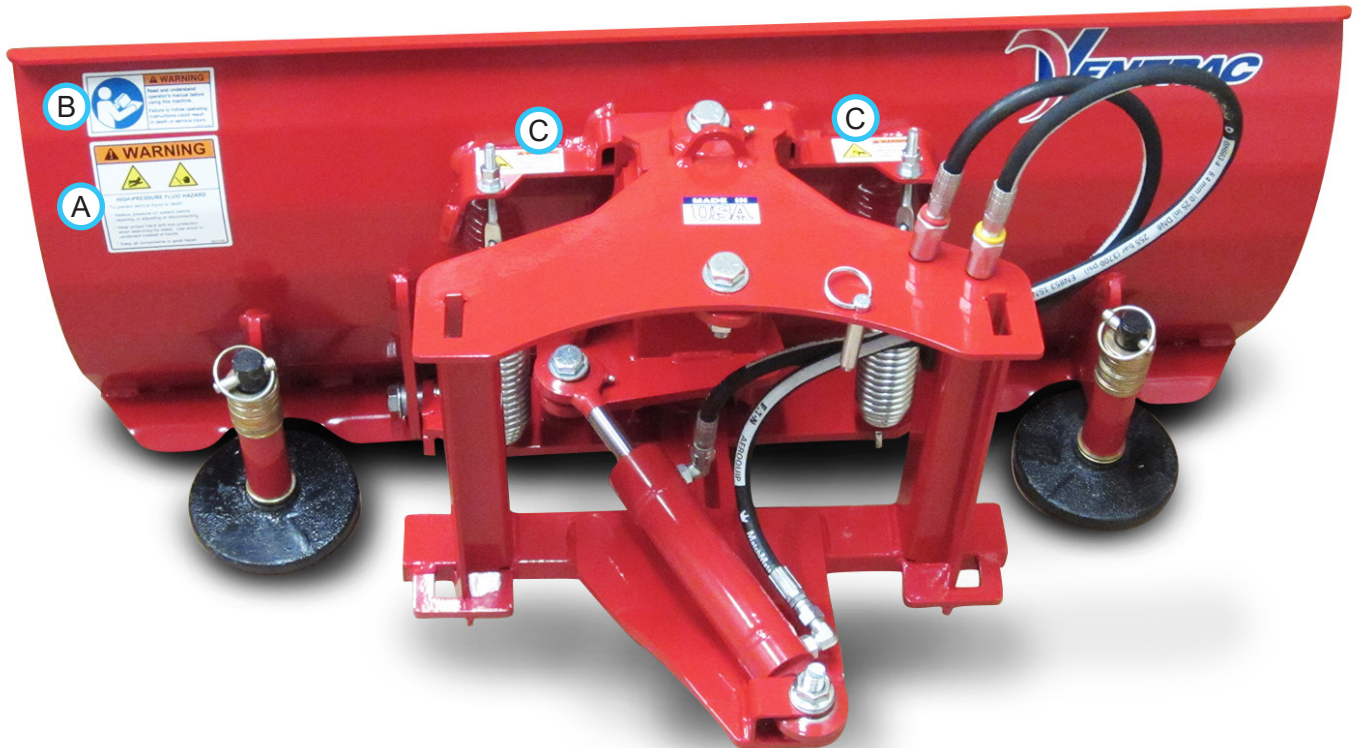

Decal	Description	Part Number	Quantity
A	Warning, High Pressure Fluid Hazard	00.0103	1
B	Warning, Read Owner's Manual	00.0217	1
C	Warning, Pinch Point	00.0218	2

SAFETY



General Safety Procedures for Ventrac SSV Power Units, Attachments, & Accessories



Training Required

- The owner of this machine is solely responsible for properly training the operators.
- The owner/operator is solely responsible for the operation of this machine and for the prevention of accidents or injuries occurring to him/herself, other people, or property.
- Do not allow operation or service by children or untrained personnel. Local regulations may restrict the age of the operator.
- Before operating this machine, read the operator's manual and understand its contents.
- If the operator of the machine cannot understand this manual, then it is the responsibility of this machine's owner to fully explain the material within this manual to the operator.
- Learn and understand the use of all the controls.
- Know how to stop the power unit and the attachments quickly in the event of an emergency.

Requirements for Personal Protective Equipment (PPE)

- The owner is responsible for ensuring that all the operators use the proper PPE while operating the machine. Whenever you use the machine, use the following PPE:
- Certified eye protection and hearing protection.
- Closed toe, slip resistant footwear.
- Long pants or trousers.
- A dust mask for dusty conditions.
- Appropriate cold weather clothing.
- Additional PPE may be required. Refer to the product safety procedures for any additional requirements.

Operation Safety

- Secure long hair and loose clothing. Do not wear jewelry.
- Inspect the machine before operation. Repair or replace any damaged, worn, or missing parts. Be sure the guards and shields are in proper working condition and are secured in place. Make any necessary adjustments before operating the machine.
- Some pictures in this manual may show shields or covers opened or removed in order to clearly illustrate the instructions. Under no circumstance should the machine be operated without these devices in place.
- Alterations or modifications to this machine can reduce safety and could cause damage to the machine. Do not alter the safety devices or operate with the shields or covers removed.
- Before each use, verify that all the controls function properly and inspect all the safety devices. Do not operate if the controls or safety devices are not in proper working condition.
- Check the parking brake function before operating. Repair or adjust the parking brake if necessary.
- Observe and follow all of the safety decals.
- All the controls are to be operated from the operator's station only.
- Ensure the attachment or accessory is locked or fastened securely to the power unit before operating.
- Ensure that all bystanders are clear of the power unit and the attachment before operating. Stop the machine if someone enters your work area.
- Always be alert to what is happening around you, but do not lose focus on the task you are performing. Always look in the direction the machine is moving.
- Look behind and down before backing up to be sure of a clear path.

SAFETY



General Safety Procedures for Ventrac Power Units, Attachments, & Accessories



- If you hit an object, stop and inspect the machine. Make any necessary repairs before operating the machine again.
- Stop operation immediately at any sign of equipment failure. An unusual noise can be a warning of equipment failure or a sign that maintenance is required. Make any necessary repairs before operating the machine again.
- Do not leave the machine unattended while it is running.
- Always park the machine on level ground.
- Always shut off the engine when connecting the attachment drive belt to the power unit.
- Never leave the operator's station without lowering the attachment to the ground, engaging the parking brake, shutting off the engine, and removing the ignition key. Make sure all moving parts have come to a complete stop before dismounting.
- Never leave the machine unattended without lowering the attachment to the ground, engaging the parking brake, shutting off the engine, and removing the ignition key.
- Only operate in well-lit conditions.
- Do not operate when there is a risk of lightning.
- Never direct the discharge of any attachment in the direction of people, buildings, animals, vehicles, or other objects of value.
- Never discharge material against a wall or obstruction. The material may ricochet back toward the operator.
- Use extra caution when approaching blind corners, shrubs, trees, or other objects that may obscure your vision.
- Do not run the engine in a building without adequate ventilation.
- Do not touch the engine or the muffler while the engine is running or immediately after stopping the engine. These areas may be hot enough to cause a burn.
- Do not change the engine governor settings or over-speed the engine. Operating the engine at excessive speeds may increase the hazard of personal injury.
- To reduce the hazard of fire, keep the battery compartment, engine, and muffler areas free of grass, leaves, excessive grease, and other flammable materials.
- Clear the working area of objects that might be hit or thrown from the machine.
- Keep people and pets out of the working area.
- Know the work area well before operation. Do not operate where traction or stability is questionable.
- Reduce speed when you are operating over rough ground.
- Equipment can cause serious injury and/or death when improperly used. Before operating, know and understand the operation and safety of the power unit and the attachment being used.
- Do not operate the machine if you are not in good physical and mental health, if you will be distracted by personal devices, or if you are under the influence of any substance which might impair your decisions, dexterity, or judgment.
- Children are attracted to machine activity. Be aware of children and do not allow them in the work area. Turn off the machine if a child enters the work area.

Keep Riders Off

- Only allow the operator on the power unit. Keep riders off.
- Never allow riders on any attachment or accessory.

SAFETY



General Safety Procedures for Ventrac Power Units, Attachments, & Accessories



Operating On Slopes

- Slopes can cause loss-of-control and tip-over accidents, which can result in severe injury or death. Be familiar with the emergency parking brake, along with the power unit controls and their functions.
- Do not operate on slopes greater than 10 degrees.
- Do not stop or start suddenly when operating on slopes.
- Variables such as wet surfaces and loose ground will reduce the degree of safety. Do not drive where the machine could lose traction or tip over.
- Keep alert for hidden hazards in the terrain.
- Stay away from drop-offs, ditches, and embankments.
- Sharp turns should be avoided when operating on slopes.
- Transport the machine with the attachment lowered or close to the ground to improve stability.
- While operating on slopes, drive in an up and down direction whenever possible. If turning is necessary while driving across slopes, reduce your speed and turn slowly in the downhill direction.

Roadway Safety

- Operate with safety lights when operating on or near roadways.
- Obey all state and local laws concerning operation on roadways.
- Slow down and be careful of traffic when operating near or crossing roadways. Stop before crossing roads or sidewalks. Use care when approaching areas or objects that may obscure vision.
- If there is any doubt of safety conditions, discontinue the machine operation until a time when the operation can be performed safely.

Truck Or Trailer Transport

- Use care when loading or unloading the machine into a truck or trailer.
- Use full width ramps for loading the machine into a truck or trailer.
- The parking brake is not sufficient to lock the machine during transport. Always secure the power unit and/or attachment to the transporting vehicle securely using straps, chains, cables, or ropes. Both the front and rear straps should be directed down and outward from the machine.
- Shut off the fuel supply to the power unit during transport on a truck or trailer.
- Turn the battery disconnect switch to the Off position to shut off electrical power.

Maintenance

- Keep the safety decals legible. Remove all grease, dirt, and debris from the safety decals and instructional labels.
- If any decals are faded, illegible, or missing, contact your dealer promptly for replacements.
- When new components are installed, be sure that the current safety decals are affixed to the replacement components.
- If any component requires replacement, use only original Ventrac replacement parts.
- Always turn the battery disconnect to the Off position or disconnect the battery before performing any repairs. Disconnect the negative terminal first and the positive terminal last. Reconnect the positive terminal first and the negative terminal last.
- Keep all bolts, nuts, screws, and other fasteners properly tightened.
- Always lower the attachment to the ground, engage the parking brake, shut off the engine, and remove the ignition key. Make sure all moving parts have come to a complete stop before cleaning, inspecting, adjusting, or repairing.

SAFETY



General Safety Procedures for Ventrac Power Units, Attachments, & Accessories



- If the power unit, attachment, or accessory requires repairs or adjustments not instructed in the operator's manual, the power unit, attachment, or accessory must be taken to an authorized Ventrac dealer for service.
- Never perform maintenance on the power unit and/or attachment if someone is in the operator's station.
- Always use protective glasses when handling the battery.
- Check the fuel lines for tightness and wear on a regular basis. Tighten or repair them as needed.
- To reduce the hazard of fire, keep the battery compartment, engine, and muffler areas free of grass, leaves, and excess grease.
- Do not touch the engine, the muffler, or other exhaust components while the engine is running or immediately after stopping the engine. These areas may be hot enough to cause a burn.
- Allow the engine to cool before storing and do not store near an open flame.
- Do not change the engine governor settings or over-speed the engine. Operating engine at excessive speeds may increase the hazard of personal injury.
- Springs may contain stored energy. Use caution when disengaging or removing springs and/or spring loaded components.
- An obstruction or blockage in a drive system or moving/rotating parts may cause a buildup of stored energy. When the obstruction or blockage is removed, the drive system or moving/rotating parts may move suddenly. Do not attempt to remove an obstruction or blockage with your hands. Keep your hands, feet, and clothing away from all power-driven parts.

Fuel Safety

- To avoid personal injury or property damage, use extreme care in handling gasoline. Gasoline is extremely flammable and the vapors are explosive.
- Do not refuel the machine while smoking or at a location near flames or sparks.
- Always refuel the machine outdoors.
- Do not store the machine or fuel container indoors where the fumes or fuel can reach an open flame, spark, or pilot light.
- Only store fuel in an approved container. Keep out of the reach of children.
- Never fill containers inside a vehicle or on a truck or trailer bed with a plastic liner. Always place the containers on the ground away from your vehicle before filling.
- Remove the machine from the truck or trailer and refuel it on the ground. If this is not possible, refuel the machine using a portable container, rather than from a fuel dispenser nozzle.
- Never remove the fuel cap or add fuel with the engine running. Allow the engine to cool before refueling.
- Never remove the fuel cap while on a slope. Only remove the fuel cap when parked on a level surface.
- Replace the fuel tank cap and the container cap securely.
- Do not overfill the fuel tank. Only fill to the bottom of the fuel neck, do not fill the fuel neck full. Overfilling of the fuel tank could result in engine flooding, fuel leakage from the tank, and/or damage to the emissions control system.
- If fuel is spilled, do not attempt to start the engine. Move the power unit away from the fuel spill and avoid creating any source of ignition until the fuel vapors have dissipated.
- If the fuel tank must be drained, it should be drained outdoors into an approved container.
- Check the fuel lines for tightness and wear on a regular basis. Tighten or repair them as needed.
- The fuel system is equipped with a shut-off valve. Shut off the fuel when transporting the machine to and from the job, when parking the machine indoors, or when servicing the fuel system.

SAFETY



General Safety Procedures for Ventrac Power Units, Attachments, & Accessories



Hydraulic Safety

- Make sure the hydraulic connections are tight and all hydraulic hoses and tubes are in good condition. Repair any leaks and replace any damaged or deteriorated hoses or tubes before starting the machine.
- Hydraulic leaks can occur under high pressure. Hydraulic leaks require special care and attention.
- Use a piece of cardboard and a magnifying glass to locate suspected hydraulic leaks.
- Keep your body and hands away from pinhole leaks or nozzles that eject high pressure hydraulic fluid. Hydraulic fluid escaping under high pressure can penetrate the skin causing serious injury, leading to severe complications and/or secondary infections if left untreated. If hydraulic fluid is injected into the skin, seek immediate medical attention no matter how minor the injury appears.
- The hydraulic system may contain stored energy. Before performing maintenance or repairs on the hydraulic system, remove any attachments, engage the parking brake, disengage the weight transfer system (if equipped), shut off the engine, and remove the ignition key. To relieve pressure on the auxiliary hydraulic system, shut off the power unit engine and move the hydraulic control lever left and right before disconnecting the auxiliary hydraulic quick couplers.

SAFETY



ND420 Safety Procedures



- Attachment hydraulic system may contain stored energy. Before performing maintenance or repairs on the hydraulic system, the attachment's auxiliary hydraulic hoses must be disconnected from the power unit. Lower the attachment to the ground, shut off power unit engine, move the hydraulic control lever left and right to relieve auxiliary hydraulic pressure, and disconnect the auxiliary hydraulic quick couplers.
- Always block up the snow plow securely when adjusting the skid shoes.
- Operators should be familiar with the area they are clearing and make preparations ahead of time. Place guide stakes appropriately and remove stones, markers, or other debris that may be hidden after a snowfall. Curbs, offsets, steps, man hole covers, broken or raised pavement, etc. should be noted. Operators should map areas to be cleared before the winter season so they can review potential hazards prior to clearing snow in the area.
- If an area is to be cleared that is unfamiliar to the operator, travel slowly and use **EXTREME CAUTION**. Inquire of anyone who might know of potential hazards.
- Never travel at speeds that would cause injury to the operator or damage to the machine if the machine were to be stopped suddenly by an unseen, immovable object.
- Always operate the snow plow with the safety trip control in the unlocked position, unless operating at very slow speeds.
- Ensure there are no objects between the snow plow and the power unit. When the blade is angled, objects may be crushed between the blade and power unit.
- Do not operate in poor visibility conditions.

OPERATIONAL CONTROLS

Safety Trip Control

The safety trip control allows the plow blade to be locked to the frame with a pin or unlocked which allows the plow blade to trip when it hits an immovable object.

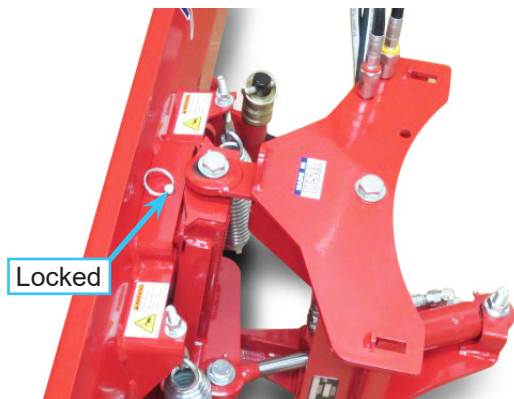
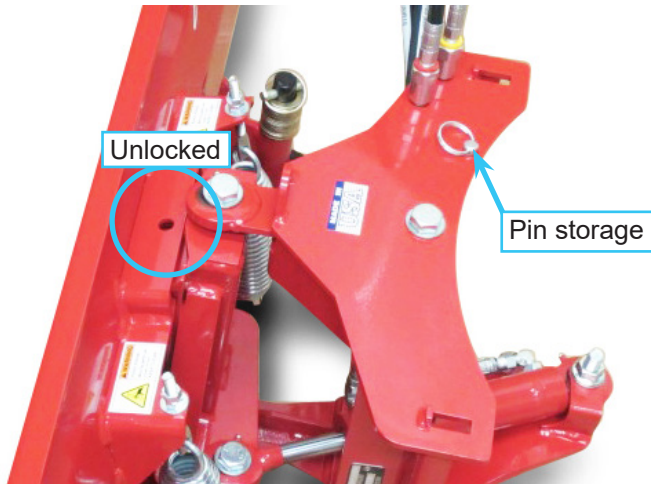

The unlocked position helps prevent sudden stops caused when contact is made with sidewalk joints, curbs, broken pavement, or other immovable objects. The unlocked position should be used for most applications. When using the plow in the unlocked position, store the pin in the hitch frame hole.

The locked position should only be used for pushing or scraping at very slow speeds.

⚠ CAUTION

The plow blade will not trip with the pin in the locked position. The machine must be operated at a very slow speed to prevent personal injury or damage to the machine if an immovable object is struck.

Plow Blade Angle

The hydraulic control lever* on the power unit controls the angle of the plow blade. The plow blade can be angled up to 30 degrees to the right or left.

⚠ WARNING

When plow blade is being angled, pinch points are created at the trailing edge of the plow blade. Make sure there are no people or objects present between the plow blade and the power unit.

* Refer to power unit operator's manual for operation of power unit controls.

GENERAL OPERATION

Daily Inspection

⚠ WARNING

Always set the parking brake, shut off power unit engine, remove the ignition key, and ensure all moving parts have come to a complete stop before inspecting components, or attempting any repair or adjustment.

1. Park machine on a level surface, with the engine shut off and all fluids cold.
2. Perform a visual inspection of both the power unit and the snow plow. Look for loose or missing hardware, damaged components, or signs of wear.
3. Inspect hydraulic hoses, hydraulic fittings, and fuel lines to ensure tight, leak free connections.
4. Inspect the cutting edge and skid shoes for wear and service as required.
5. Refer to the power unit operator's manual. Check the power unit's engine oil, hydraulic oil, tire pressure, and fuel level. Add fluid or service as required.
6. Test the power unit's operator safety interlock system*.

Attaching

1. Align the power unit squarely with the snow plow. Lower the power unit hitch until the hitch tabs are below the top plate (A) on the snow plow hitch frame.
2. Drive forward slowly until the power unit hitch tabs are aligned with the hitch point slots (B) in the snow plow hitch frame. Raise the power unit hitch to engage the tabs in the hitch frame. Continue to raise the hitch until the snow plow is lifted off the ground.
3. Engage the parking brake* and shut off the power unit engine.
4. Rotate the attachment latch handle* forward to the latched position. Make sure the latch tabs are engaged in the lower latch plates, and the latch handle lock is engaged to prevent accidental disengagement of the latch handle.
5. Wipe hose ends clean and connect to the power unit's hydraulic quick couplers. Connect the hoses and quick couplers so the red indicators are paired together and the yellow indicators are paired together.

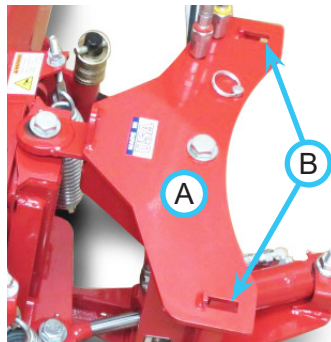

Detaching

1. Park the power unit on a level surface and set the parking brake.*
2. Lower the snow plow to the ground.
3. Shut off power unit engine.
4. Move the hydraulic control lever left and right to release pressure from the auxiliary hydraulic circuit, disconnect the hydraulic quick couplers from the power unit, and store the hose ends in the top frame holes on the snow plow.
5. Disengage the latch handle lock* and rotate the attachment latch handle* back to unlatch from the lower hitch point on the snow plow.
6. Restart the power unit and lower the power unit hitch to clear the top plate on the snow plow hitch frame while slowly backing away from the snow plow.

Operating Procedure

Before operation, perform daily inspection and verify skid shoes are set at the desired position.

Set weight transfer (if equipped) to the Off position.

Move the power unit's hydraulic control lever to the left or right to set the desired angle and direction of the plow blade.

Move the machine into position and lower the snow plow to the ground. If skid shoes are used to determine the depth of the plow, place the power unit's hydraulic control lever in the float position by pushing it forward until the detent engages. The lever will stay in this position until intentionally removed.

When cleaning hard packed snow from hard surfaces, slight down pressure on the snow plow may be used. Push the hydraulic control lever forward until there is slight down pressure on the plow and then release.

Drive forward slowly while keeping a close watch for potential hazards.

⚠ WARNING

Never push snow at high speeds or attempt to gain momentum and ram a snow pile. Sudden deceleration caused by a large amount of snow or hidden objects may cause injury to the operator and/or damage to the machine.

* Refer to power unit operator's manual for operation of power unit controls.

GENERAL OPERATION

Transport of Snow Plow

Transport the snow plow in the raised position to reduce wear of the machine and to prevent the snow plow blade from catching on curbs or other obstacles. Travel slowly over rough or slippery surfaces in order to maintain control of the power unit.

Resetting the Blade Safety Trip Control

⚠ WARNING

Pinching Hazard

If the blade safety trip control activates, the plow blade may suddenly return to the operating position. Do not leave the operator platform or attempt to manually reset the plow blade.

If the blade safety trip control is activated but the plow blade does not reset itself, do not attempt to raise the snow plow. Slowly back away from the obstacle. The plow blade will return to the operating position when it is moved away from the obstacle on which it is caught.

Skid Shoe Adjustment

Skid shoes are provided to keep the cutting edge off the surface to be cleared, especially when clearing snow from gravel driveways or walkways.

The skid shoe height is determined by the placement of spacer washers between the skid shoe and the skid shoe mount. Extra washers are stored on top of the skid shoe mount.

1. Park the power unit and snow plow on a level surface and engage the parking brake.
2. Determine the number of spacer washers that need to be moved to reach the desired skid shoe height.

⚠ WARNING

Do not make skid shoe adjustments unless the snow plow is securely supported with blocks or jack stands.

Hydraulic drift or accidental release of hydraulic pressure could allow the snow plow to lower and trap a person or appendage, if the snow plow is not securely supported.

3. Raise the snow plow to the highest position and adjust the plow angle so the plow blade is perpendicular to the power unit. Support the plow blade securely with blocks or jack stands.

4. Remove the linch pin (A) and the spacer washers (B) from the top of the skid shoe mount.

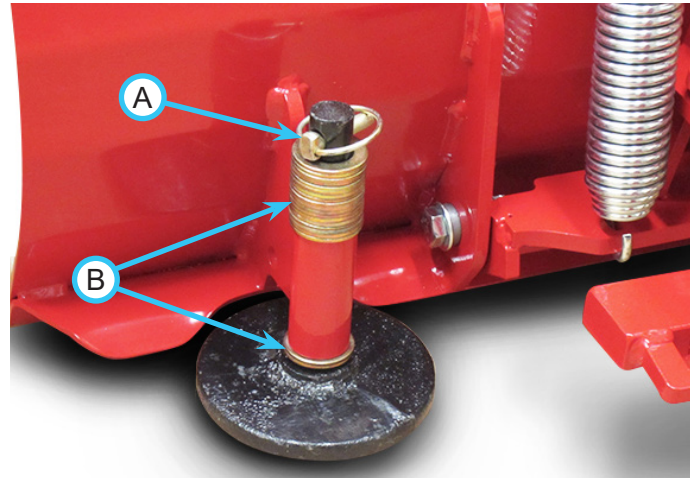

5. Remove the skid shoe from the bottom of the skid shoe mount. Add or remove spacer washers to reach the desired skid shoe height.
6. Insert the skid shoe back into the skid shoe mount, place any extra spacer washers on top of the skid shoe mount, and fasten the skid shoe in place with the linch pin. Both the left and right skid shoes should be set at the same height.
7. Remove blocks or jack stands and lower the snow plow to the ground.

NOTE: skid shoes should be set low enough to support the back of the snow plow when it is detached from the power unit, so the plow frame is in position for easy reattachment.

SERVICE

WARNING

Always set the parking brake, shut off power unit engine, remove the ignition key, and ensure all moving parts have come to a complete stop before inspecting components or attempting any repair or adjustment.



Attention

If any component requires replacement, use only original Ventrac replacement parts.

Cleaning and General Maintenance

For best results, and to maintain the finish of the snow plow, clean or wash the snow plow to remove dirt, salt deposits, and snow or ice accumulations.



Attention

To maintain the finish of the power unit and attachment, thoroughly wash the equipment after each use to remove any corrosive agents (e.g., salt). Failure to clean the equipment may result in corrosion of (including but not limited to) steel, aluminum, and electrical components. Equipment that will experience repeated exposure to corrosive agents should be pretreated with a corrosion preventative.

Cutting Edge Reversal/Replacement

If the cutting edge wears down near the blade frame structure, remove the cutting edge and flip it over so the unworn top edge is now on the bottom. Reinstall the cutting edge onto the plow blade. When both sides of the cutting edge have been worn down, the cutting edge will need to be replaced.

Skid Shoe Replacement

Skid shoes should be replaced when wear surface is less than 1/8" (3 mm) thick.

Optional Polyurethane Cutting Edge Adjustment/Reversal

When the polyurethane cutting edge wears down near the blade frame, remove the poly edge from the blade frame, move down to align the upper set of mounting holes with the holes in the blade frame, and reinstall onto the blade frame. This provides an additional 1-1/8" (28.5 mm) of wear.

When the poly edge wears down near the blade frame again, remove the poly edge and flip it over so the unworn top edge is now on the bottom. Reinstall the poly edge onto the blade frame using the lower set of mounting holes. When the poly edge wears down, reposition to use the upper set of mounting holes to provide an additional 1-1/8" (28.5 mm) of wear.

After both sides of the polyurethane cutting edge have been worn down, the cutting edge will need to be replaced.

SERVICE

Lubrication Locations

Lubrication is required at the following locations using a lithium complex NLGI #2 grease. Refer to the maintenance schedule for service intervals and amount of grease.

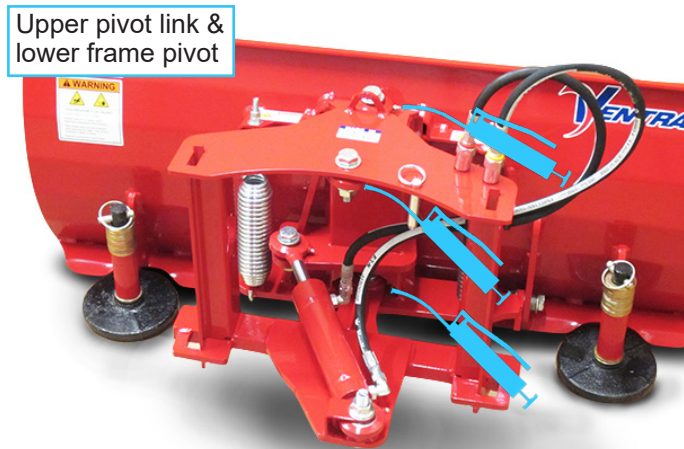
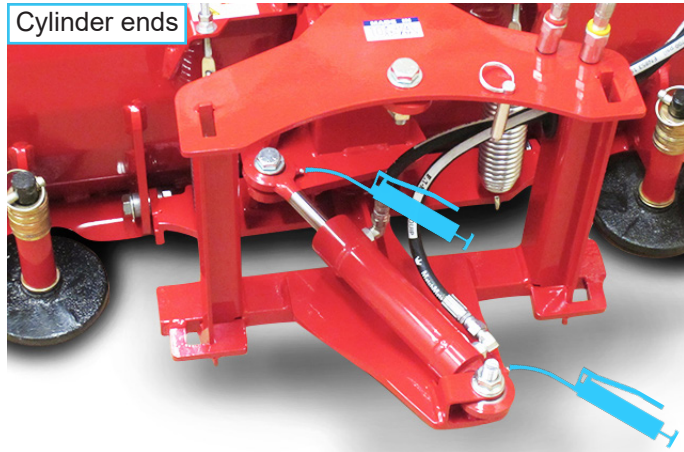

Angling the snow plow blade to the left helps increase access to the grease fitting in the lower frame pivot.

Storage

Preparing the Snow Plow for Storage

1. Clean the snow plow.



Attention

To maintain the finish of the power unit and attachment, thoroughly wash the equipment to remove any corrosive agents (e.g., salt). Failure to clean the equipment may result in corrosion of (including but not limited to) steel, aluminum, and electrical components.

2. Inspect for loose or missing hardware, damaged components, or signs of wear. Repair or replace as necessary.
3. Inspect safety decals. Replace any safety decals that are faded, illegible, or missing.
4. Inspect cutting edge and skid shoes for wear and service as required.
5. Service all lubrication points.
6. Inspect painted surfaces for chips, scratches, or rust. Clean and touch up surfaces as needed.

Removing the Snow Plow from Storage

1. Clean the snow plow to remove any accumulated dust or debris.
2. Inspect the snow plow as instructed in the daily inspection section of this manual.
3. Test the snow plow to ensure all components are working properly.

SERVICE

Maintenance Schedule

Maintenance Schedule	# of Locations	# of Pumps	AS NEEDED	Daily	At 50 Hours	At 100 Hours	At 150 Hours	At 200 Hours	At 250 Hours	At 300 Hours	At 350 Hours	At 400 Hours	At 450 Hours	At 500 Hours	At 550 Hours	At 600 Hours	At 650 Hours	At 700 Hours	At 750 Hours	At 800 Hours	At 850 Hours	At 900 Hours	At 950 Hours	At 1000 Hours	Yearly	
	Grease & Lubrication: See Lubrication Section																									
Cylinder Ends	2	^	**		✓	✓	✓	✓	✓	✓	✓	✓	✓	✓	✓	✓	✓	✓	✓	✓	✓	✓	✓	✓	✓	
Upper Pivot Link	2	^	**		✓	✓	✓	✓	✓	✓	✓	✓	✓	✓	✓	✓	✓	✓	✓	✓	✓	✓	✓	✓	✓	
Lower Frame Pivot	1	^	**		✓	✓	✓	✓	✓	✓	✓	✓	✓	✓	✓	✓	✓	✓	✓	✓	✓	✓	✓	✓	✓	
Inspection																										
Inspect for Loose, Missing, or Worn Components.				✓																						
Inspect Cutting Edge, Skid Shoes, Fittings, & Hydraulic Hoses				✓																						
Inspect Safety Decals				✓																						
** Operation in severe conditions may require more frequent service intervals.																										
^ Grease until fresh grease is visible.																										

Maintenance Checklist

Maintenance Checklist	# of Locations	# of Pumps	At 50 Hours	At 100 Hours	At 150 Hours	At 200 Hours	At 250 Hours	At 300 Hours	At 350 Hours	At 400 Hours	At 450 Hours	At 500 Hours	At 550 Hours	At 600 Hours	At 650 Hours	At 700 Hours	At 750 Hours	At 800 Hours	At 850 Hours	At 900 Hours	At 950 Hours	At 1000 Hours	Yearly		
	Grease & Lubrication: See Lubrication Section																								
Cylinder Ends	2	^																							
Upper Pivot Link	2	^																							
Lower Frame Pivot	1	^																							
Inspection																									
Inspect for Loose, Missing, or Worn Components.																									
Inspect Cutting Edge, Skid Shoes, Fittings, & Hydraulic Hoses																									
Inspect Safety Decals																									
** Operation in severe conditions may require more frequent service intervals.																									
^ Grease until fresh grease is visible.																									

SPECIFICATIONS

Dimensions

Overall Height	19-1/2 inches (49.5 cm)
Overall Length	21 inches (53.3 cm)
Overall Width	42 inches (106.7 cm)
Angled Width	36 inches (91.4 cm)
Weight	165 pounds (74.5 kg)
Angle30 degrees
Ground clearance in raised position (no angle)	11 inches (27.9 cm)

Features

- Reversible and replaceable cutting edge
- Adjustable skid shoes
- Spring controlled plow blade safety trip mechanism
- Self leveling blade

Blank Page

PARTS

ILLUSTRATED DRAWING Hitch Frame & Upper Link

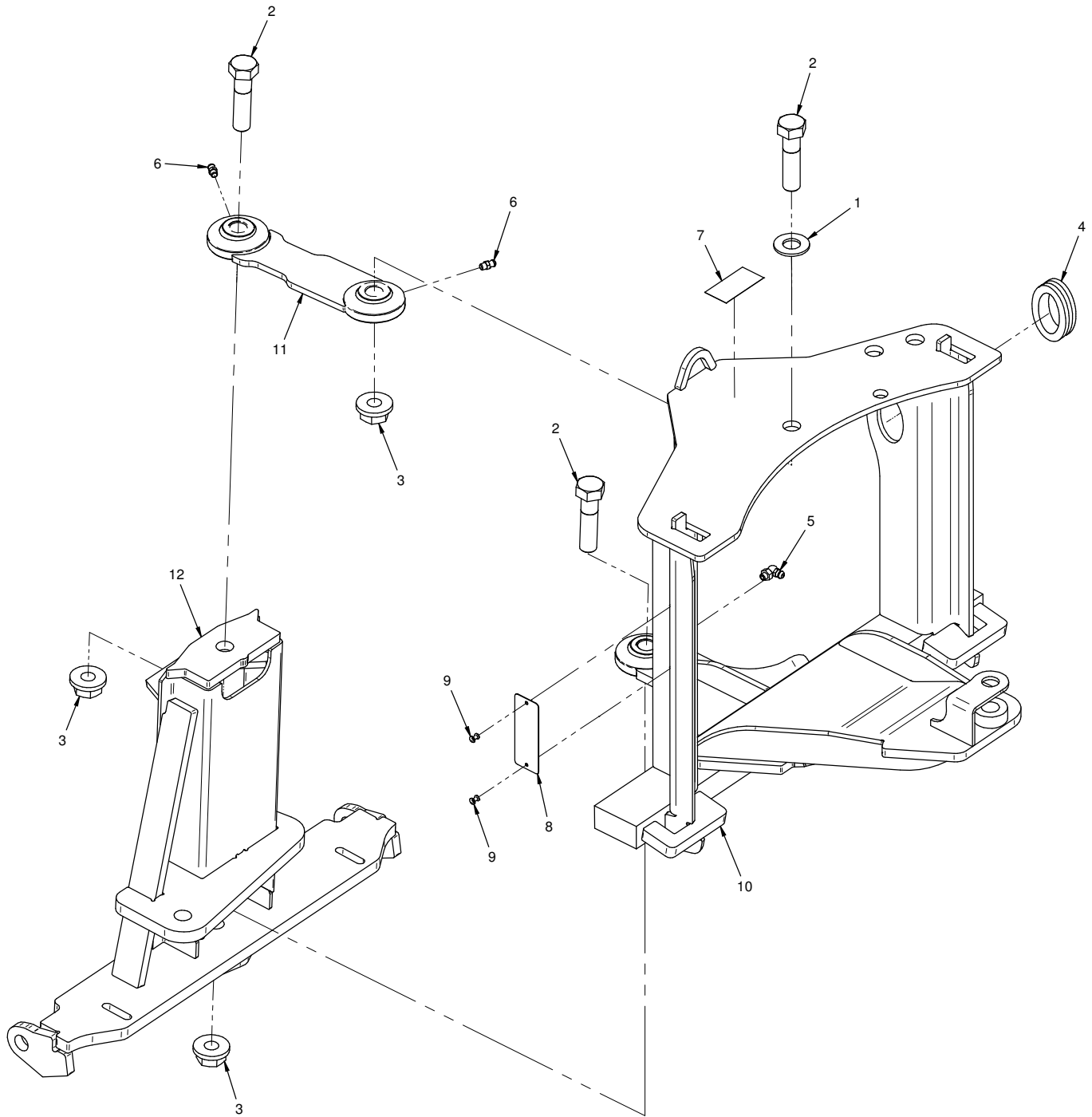

PARTS

Hitch Frame & Upper Link

REF.	PART NO.	DESCRIPTION	QTY.
1	95.10	.Washer, Flat 5/8 SAE	1
2	90.1020	.Bolt, 5/8-11 USS x 2-1/2	3
3	99.E0094	.Locknut, 5/8-11 Flanged Stover	3
4	05.0036	.Grommet, 1-1/2ID, 2-1/8OD, 9/16T	1
5	29.GF0002	.Grease Ftg, 1/4 SAE 90	1
6	29.GF0001	.Grease Ftg, 1/4 SAE ST	2
7	00.0100	.Decal, Made In USA	1
8	N/A	.Plate, Ventrac Serial Number	1
9	04.0029	.Rivet, Pop 1/8" X 1/4"	2
10	ND-6003	.Frame, Main Hitch	1
11	ND-6004	.Link, Upper Pivot	1
12	ND-6002	.Frame, Blade Pivot	1

PARTS

ILLUSTRATED DRAWING Blade Pivot Frame, Blade, & Cutting Edge

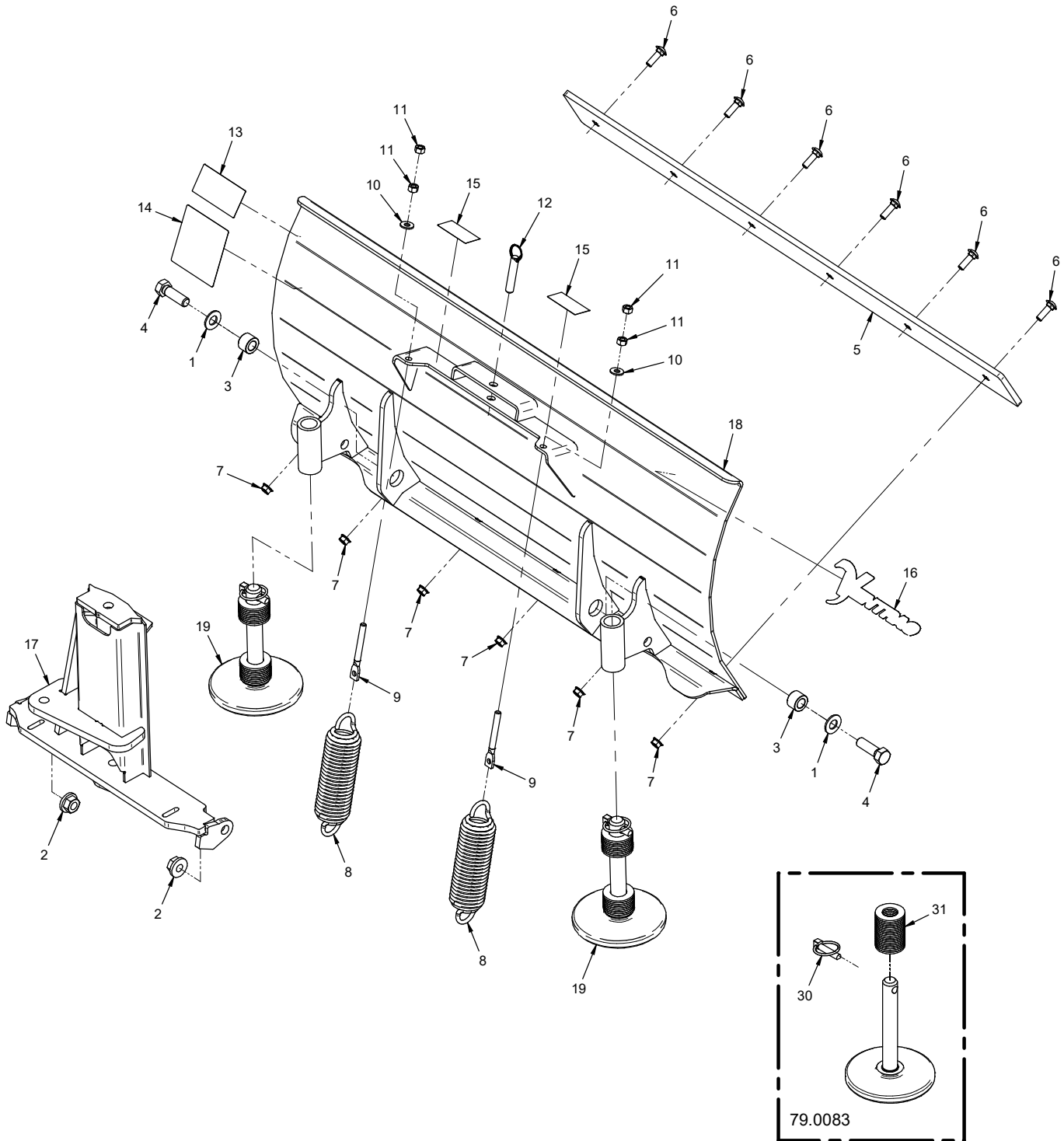

PARTS

Blade Pivot Frame, Blade, & Cutting Edge

REF.	PART NO.	DESCRIPTION	QTY.
1	95.10	.Washer, Flat 5/8 SAE	2
2	99.E0094	.Locknut, 5/8-11 Flanged Stover	2
3	64.1997	.Bushing, Blade Pivot	2
4	90.1016	.Bolt, 5/8-11 UNC x 2	2
5	78.0063	.Cutting Edge, 3/8" x 3-1/2" x 42"	1
6	97.0610	.Bolt, Carriage 3/8 x 1-1/4	6
7	99.SF06	.Nut, SRF 3/8-16 USS	6
8	41.0075	.Spring, Ext 2" OD X 8-3/8" LG	2
9	99.K0094	.Bolt, Hanger 3/8-16 X 4	2
10	94.05	.Washer, Flat 5/16 USS	2
11	92.06	.Nut, Hex 3/8-16 UNC	4
12	03.0007	.Pin, Ball 1/2 x 1.8"	1
13	00.0217	.Decal, Warning Read Owners Man	1
14	00.0103	.Decal, Hazard - High Press. Fluid	1
15	00.0218	.Decal, Warning Pinch Point	2
16	00.0383	.Decal, Ventrac	1
17	ND-6002	.Frame, Blade Pivot	1
18	ND-6001	.Blade, Main Weldment	1
19	79.0083	.Shoe, Skid Round Asm.	2
30	03.0005	.Pin, Linch	1
31	95.16	.Washer, Flat 1 SAE	19

PARTS

ILLUSTRATED DRAWING Hydraulic Power Angle

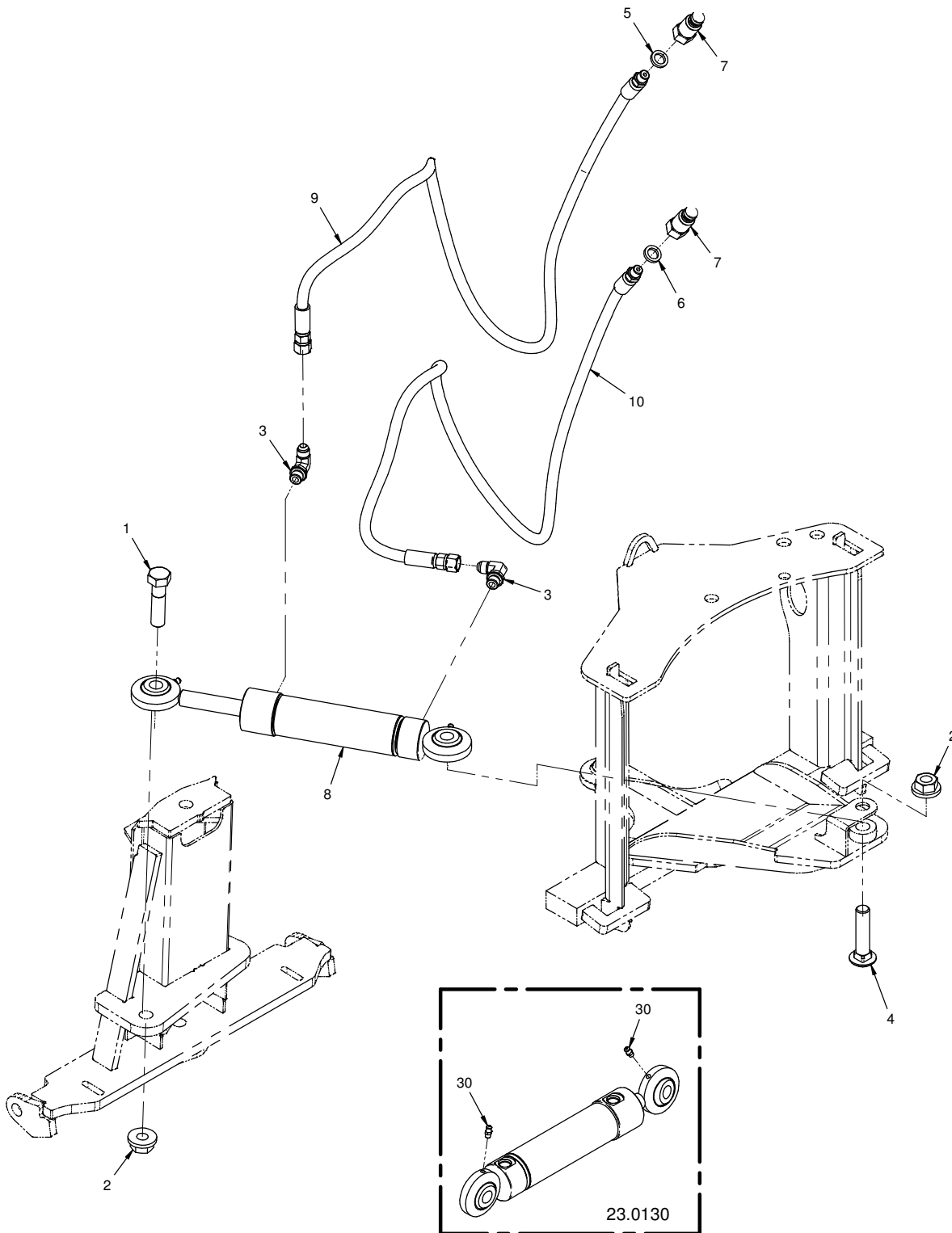

PARTS

Hydraulic Power Angle

REF.	PART NO.	DESCRIPTION	QTY.
1	90.1020	.Bolt, 5/8-11 USS x 2-1/2	1
2	99.E0094	.Locknut, 5/8-11 Flanged Stover	2
3	25.6801-06-06-CP	.Fitting, 90 ME 3/8 x 3/8	2
4	97.1022	.Bolt, Carriage 5/8-11 x 2-3/4	1
5	05.0116	.Washer, .544 ID x .817 x .14 Red	1
6	05.0117	.Washer, .544 ID x .817 x .14 Yel	1
7	23.0176	.Coupler, Male Flat Face Quick 1/4	2
8	23.0130	.Cylinder, 1-1/2" X 5"	1
9	20.0346	.Hose, 1/4x30.00 SAE 100R17AR	1
10	20.0347	.Hose, 1/4x35.00 SAE 100R17AR	1
30	29.GF0001	.Grease Ftg, 1/4 SAE ST	2

PARTS

ILLUSTRATED DRAWING 70.8181 Polyurethane Edge Kit

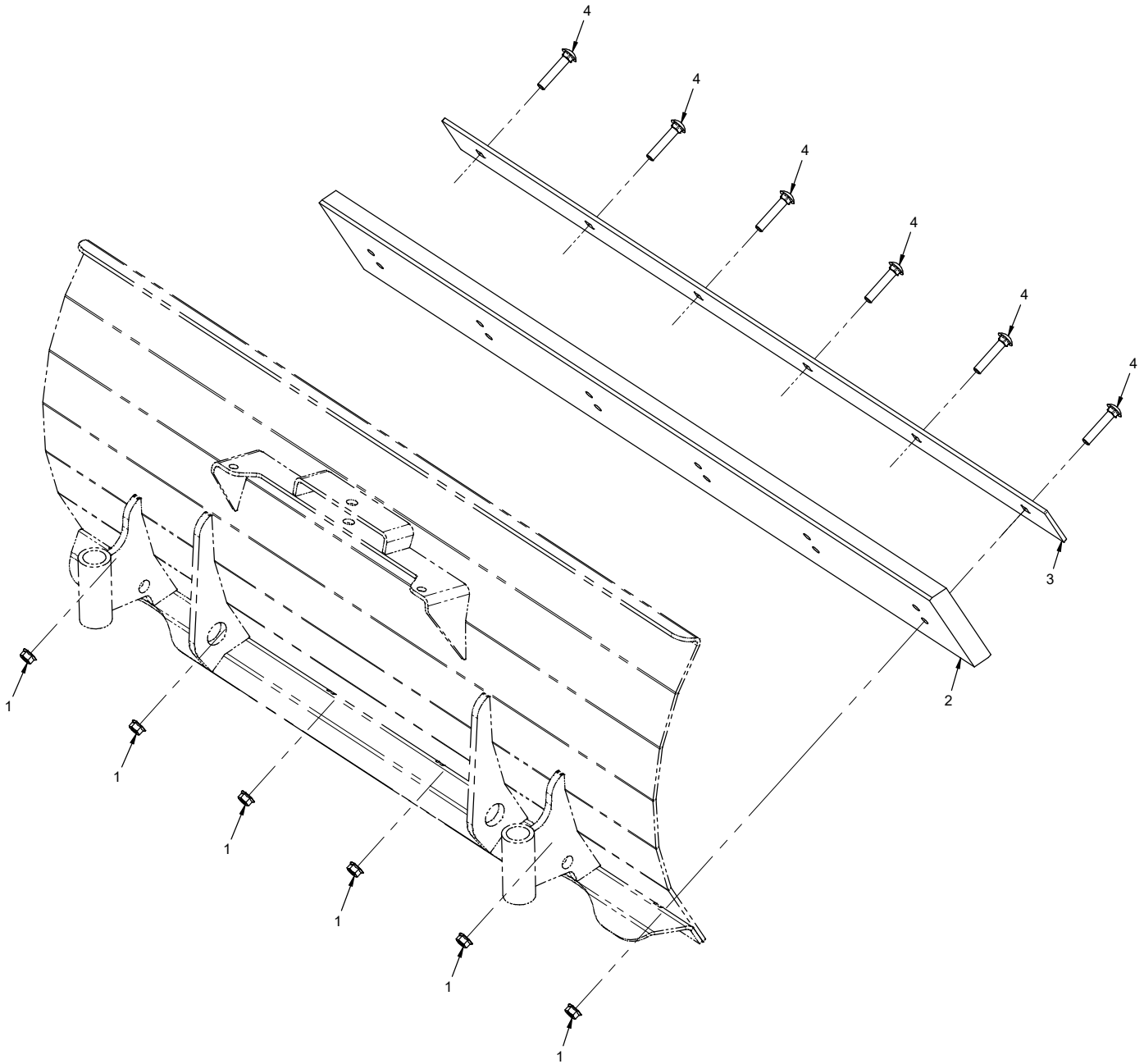

PARTS

70.8181 Polyurethane Edge Kit

REF.	PART NO.	DESCRIPTION	QTY.
1	99.SF06	Nut, SRF 3/8-16 USS	6
2	44.0391	Cutting Edge, Poly 1 x 6 x 42"	1
3	64.1998	Clamp, Poly Backer 41-1/2"	1
4	97.0616	Bolt, Carriage 3/8 x 2	6

WARRANTY



LIMITED WARRANTY - VENTRAC COMMERCIAL EQUIPMENT

Venture Products, Inc., (henceforth referred to as V.P.I.) warrants on the terms and conditions herein, that it will repair, replace, or adjust any part manufactured by Venture Products Inc., and found by Venture Products, Inc., to be defective in material and/or workmanship during the applicable warranty term.

All Ventrac commercial equipment purchased and registered on or after January 1, 2019 will carry a 2-year commercial warranty. The warranty period begins on the date of original customer purchase:

Ventrac Commercial Equipment	Warranty Term
2100 SSV & Attachments	2-year
3000 Series Tractors & Attachments	2-year
4000 Series Tractors & Attachments	2-year

All Ventrac add-on kits and accessories such as: 3-point hitch, 12V front & rear power outlets, foot pedal, dual wheel kit, etc., will be covered under the above warranty periods provided they are installed by an Authorized Ventrac Dealer. This warranty may be transferred and will carry the remainder of the warranty starting from the original purchase/registration date with the dealership and/or V.P.I.

The engine warranty is covered by its respective engine manufacturer. Please refer to the engine manufacturer's warranty statement that is included in the owner's manual.

For warranty consideration on Ventrac commercial equipment, including any defective part, must be returned to an Authorized Ventrac Dealer within the warranty period. The warranty shall extend to the cost to repair or replace (as determined by V.P.I.) the defective part. The expense of pickup and delivery of equipment, service call drive time or any transportation expense incurred for warranty repair is the sole responsibility of the owner and is not covered under warranty by Ventrac and/or V.P.I. Ventrac and V.P.I.'s responsibility in respect to claims is limited to making the required repairs or replacements, and no claim of breach of warranty shall be cause for cancellation or rescission of the contract of sale of any Ventrac equipment. Proof of purchase may be required by the dealer to substantiate any warranty claim. Only warranty work performed and submitted by an Authorized Ventrac Dealer may be eligible for warranty credit.

This warranty extends only to Ventrac commercial equipment operated under normal conditions and properly serviced and maintained. The warranty expressly does NOT cover: (a) any defects, damage or deterioration due to normal use, wear and tear, or exposure; (b) normal maintenance services, such as cleaning, lubrication, oil change; (c) replacement of service items, such as oil, lubricants, spark plugs, belts, rubber hoses, bearings or other items subject to normal service replacement; (d) damage or defects arising out of, or relating to abuse, misuse, neglect, alteration, negligence or accident; (e) repair or replacement arising from operation of, or use of the equipment which is not in accordance with operating instructions as specified in the operator's manual or other operational instructions provided by V.P.I.; (f) repair or replacement arising as a result of any operation from Ventrac equipment that has been altered or modified so as to, in the determination of V.P.I., adversely affect the operation, performance or durability of the equipment or that has altered, modified or affected the equipment so as to change the intended use of the product; (g) repair or replacement necessitated by the use of parts, accessories or supplies, including gasoline, oil or lubricants, incompatible with the equipment or other than as recommended in the operator's manual or other operational instructions provided by V.P.I.; (h) repairs or replacements resulting from parts or accessories which have adversely affected the operation, performance or durability of the equipment; or (i) damage or defects due to or arising out of repair of Ventrac equipment by person or persons other than an authorized Ventrac service dealer or the installation of parts other than genuine Ventrac parts or Ventrac recommended parts.

WARRANTY



LIMITED WARRANTY - VENTRAC COMMERCIAL EQUIPMENT

The sole liability of V.P.I. with respect to this warranty shall be the repair and replacement as set forth herein. V.P.I. shall have no liability for any other cost, loss, or damage. In particular V.P.I. shall have no liability or responsibility for: (i) expenses relating to gasoline, oil, lubricants; (ii) loss, cost or expense relating to transportation or delivery of turf equipment from the location of owner or location where used by owner to or from any Authorized Ventrac Dealer; (iii) travel time, overtime, after hours' time or other extraordinary repair charges or charge relating to repairs or replacements outside of normal business hours at the place of business of an Authorized Ventrac Dealer; (iv) rental of like or similar replacement equipment during the period of any warranty repair or replacement work; (v) any telephone or telegram charges; (vi) loss or damage to person or property other than that covered by the terms of this warranty; (vii) any claims for lost revenue, lost profit or additional cost or expense incurred as a result of a claim of breach of warranty; or (viii) attorney's fees.

The remedies of buyer set forth herein are exclusive and are in lieu of all other remedies. The liability of V.P.I., whether in contract, tort, under any warranty, or otherwise, shall not extend beyond its obligation as set forth herein. V.P.I. shall not be liable for cost of removal or installation nor shall V.P.I. be responsible for any direct, indirect, special or consequential damages of any nature. In no event shall V.P.I. be liable for any sum in excess of the price received for the goods for which liability is claimed.

There are no representations or warranties which have been authorized to the buyer of the Ventrac commercial equipment other than set forth in this warranty. Any and all statements or representations made by any seller of this equipment, including those set forth in any sales literature or made orally by any sales representative, are superseded by the terms of this warranty. Any affirmation of fact or promise made by V.P.I. or any of its representatives to the buyer which relates to the goods that are the subject to this warranty shall not be regarded as part of the basis of the bargain and shall not be deemed to create any express warranty that such goods shall conform to the affirmation or promise.

No employee, distributor, or representative is authorized to change the foregoing warranties in any way or grant any other warranty on behalf of V.P.I.

Some states do not allow limitations on how long an implied warranty lasts or allow the exclusion on limitation of incidental or consequential damages, so the above limitation or exclusion may not apply to you.

This warranty gives you specific legal rights, and you may also have other rights which vary from state to state.

This warranty applies to all Ventrac commercial equipment sold by Venture Products Inc.